

# SPECIFICATION

Model No. : **SGP.25D**

Part No. : **SGP.1575.25.4.D.02**

Product Name : **GPS SMT Patch Antenna**

Features : 25mm\*25mm\*4mm  
 1575MHz Centre Frequency  
 Patent Pending

**RoHS** ✓ Halogen Free Compliant

Photo :

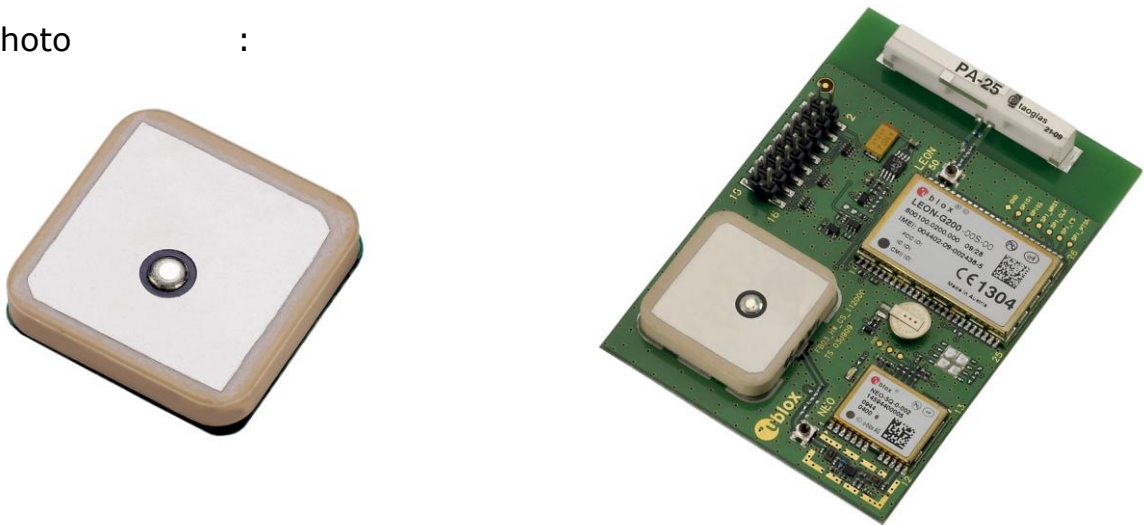

## 1. Introduction

This ceramic GPS patch antenna is based on smart **XtremeGain™** technology. It is mounted via SMT process and has been tuned as the optimal solution for the ublox C16-G25Q GSM/GPS Integrated reference Design.

The C16-G25Q GSM/GPS reference design is a complete and integrated solution for telematics applications such as fleet management, asset tracking, road pricing, and security/surveillance. It demonstrates the integration of u-blox' NEO-5Q GPS receiver with a LEON-G200 GPRS/GSM module. This 100% SMD solution uses SMT passive GPS (Taoglas SGP.25D) and GSM antenna (Taoglas PA.25A) and an on-board SIM Chip with activated phone number (SIM holder optional for mechanical (SIM)).

On the test fixture of 63.2 x 50.03 mm (GND Plane) the antenna has a centre frequency of 1567MHz ± 3MHz

## 2. Specification

No	Parameter	Specification
1	Range of Receiving Frequency	1575MHz +/- 1.023MHz
2	Bandwidth	22 MHz min with Return Loss <-10dB
3	VSWR	1.5 max
4	Gain at Zenith	+1.0 dBic typ.
5	Axial ratio	4.0 dB Max.
6	Impedance	50 Ω
7	Polarization	Right Hand Circular Polarization
8	Frequency Temperature Coefficient	0 ± 20 ppm/ °C max @ -40°C to +85°C
9	Operating Temperature	-40°C to +85°C

### 3. Electrical Specifications

#### 3.1 Return Loss, SWR, Impedance (For Ublox C16-G25Q Reference Design)

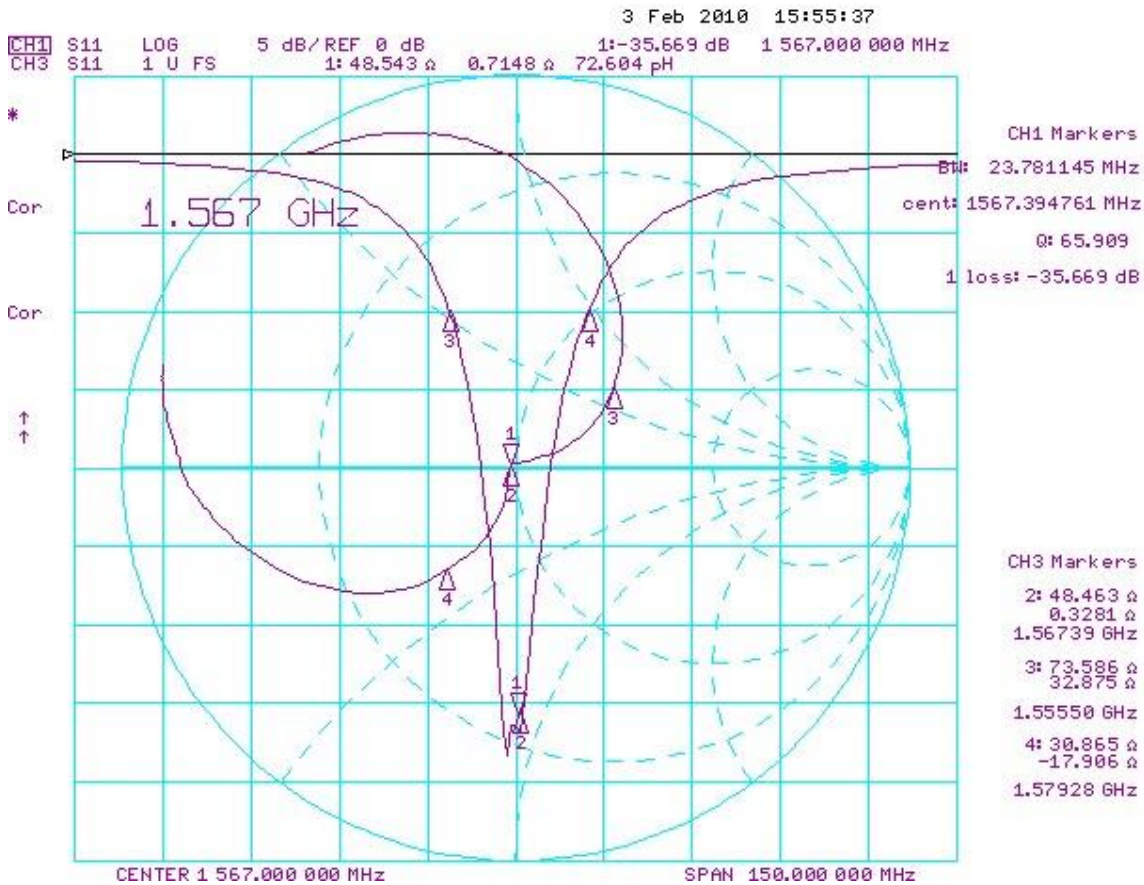

### 3.2 Matching Circuit

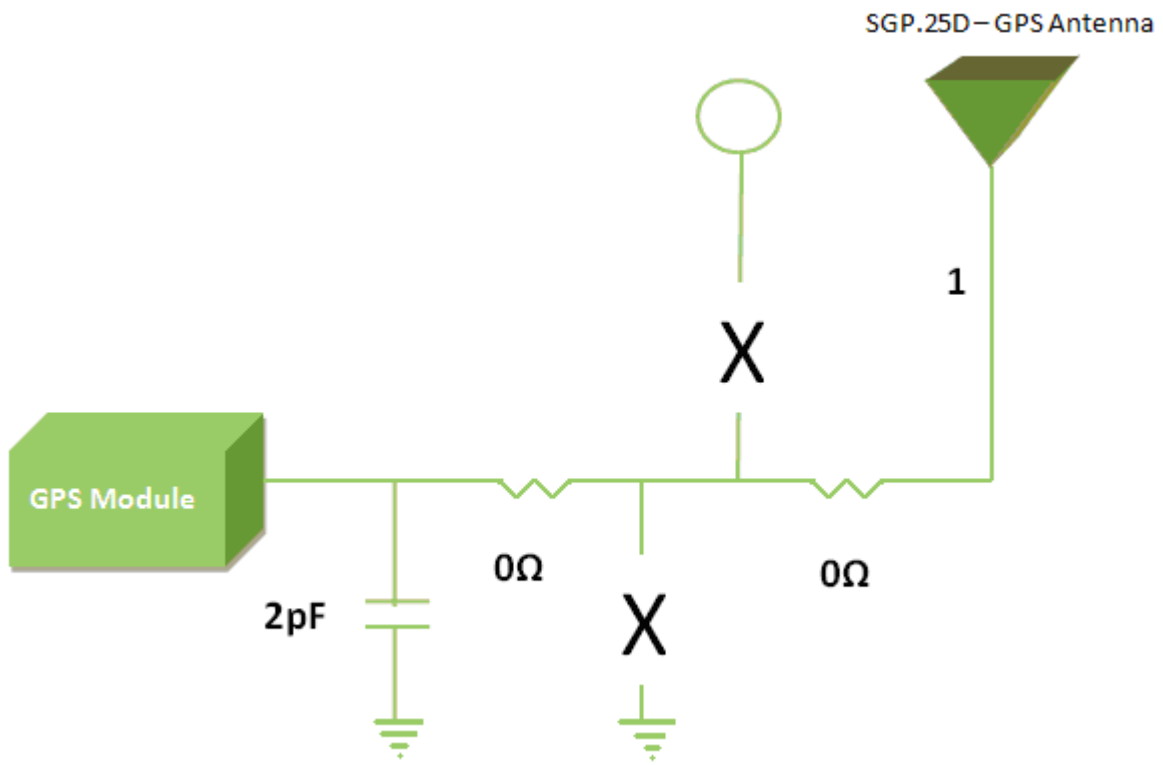

### 3.3 Axial Ratio

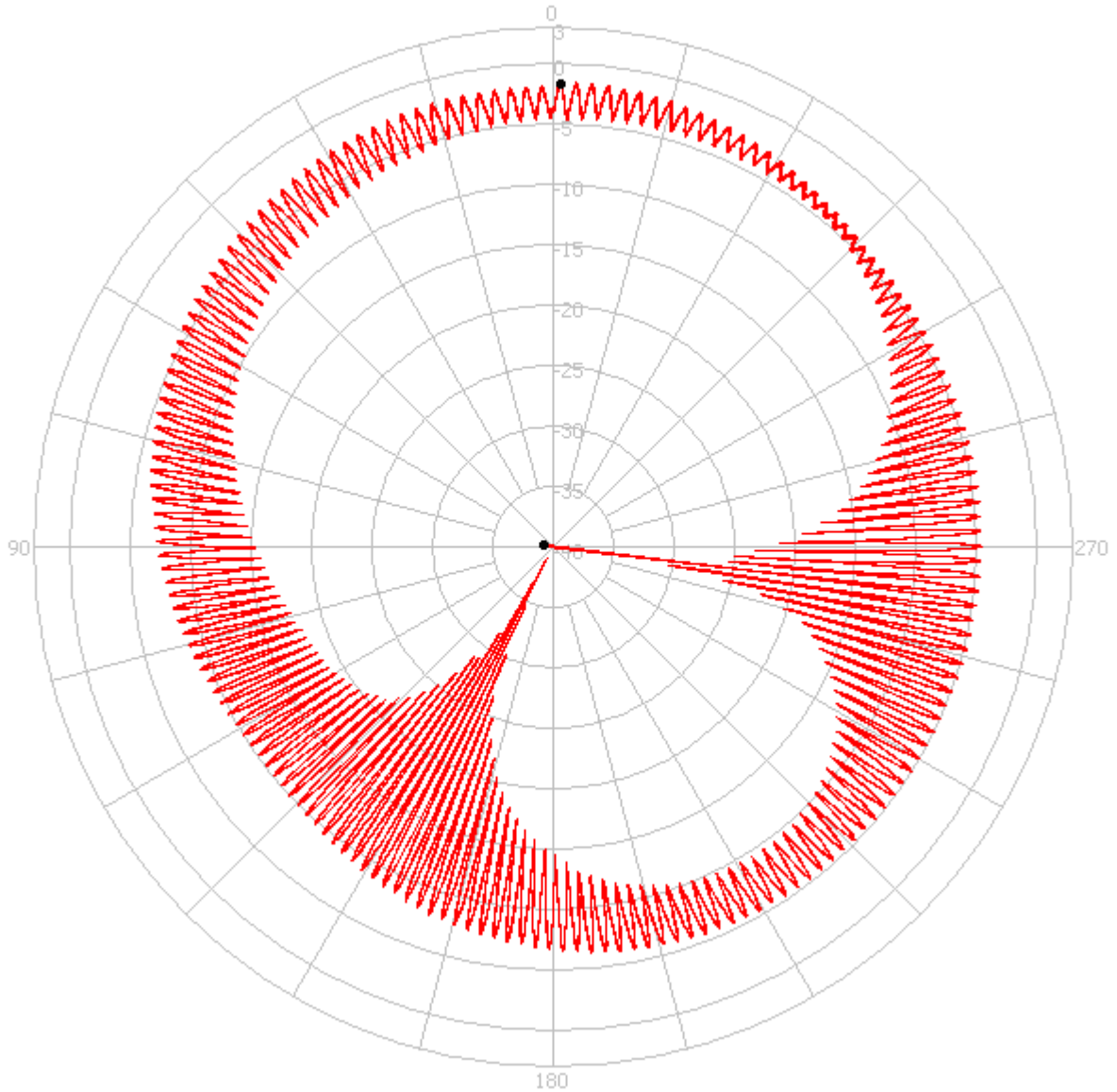

Test Mode	Freq (MHz)	Max Gain (dBi)	Min Gain (dBi)	Avg Gain (dBi)	Source Polar.
Axial Ratio	1575.42	-1.67 / 359.10	-40.80 / 263.03	-6.46	CP

### 3.4 Cut plane patterns

#### X - Z Plane

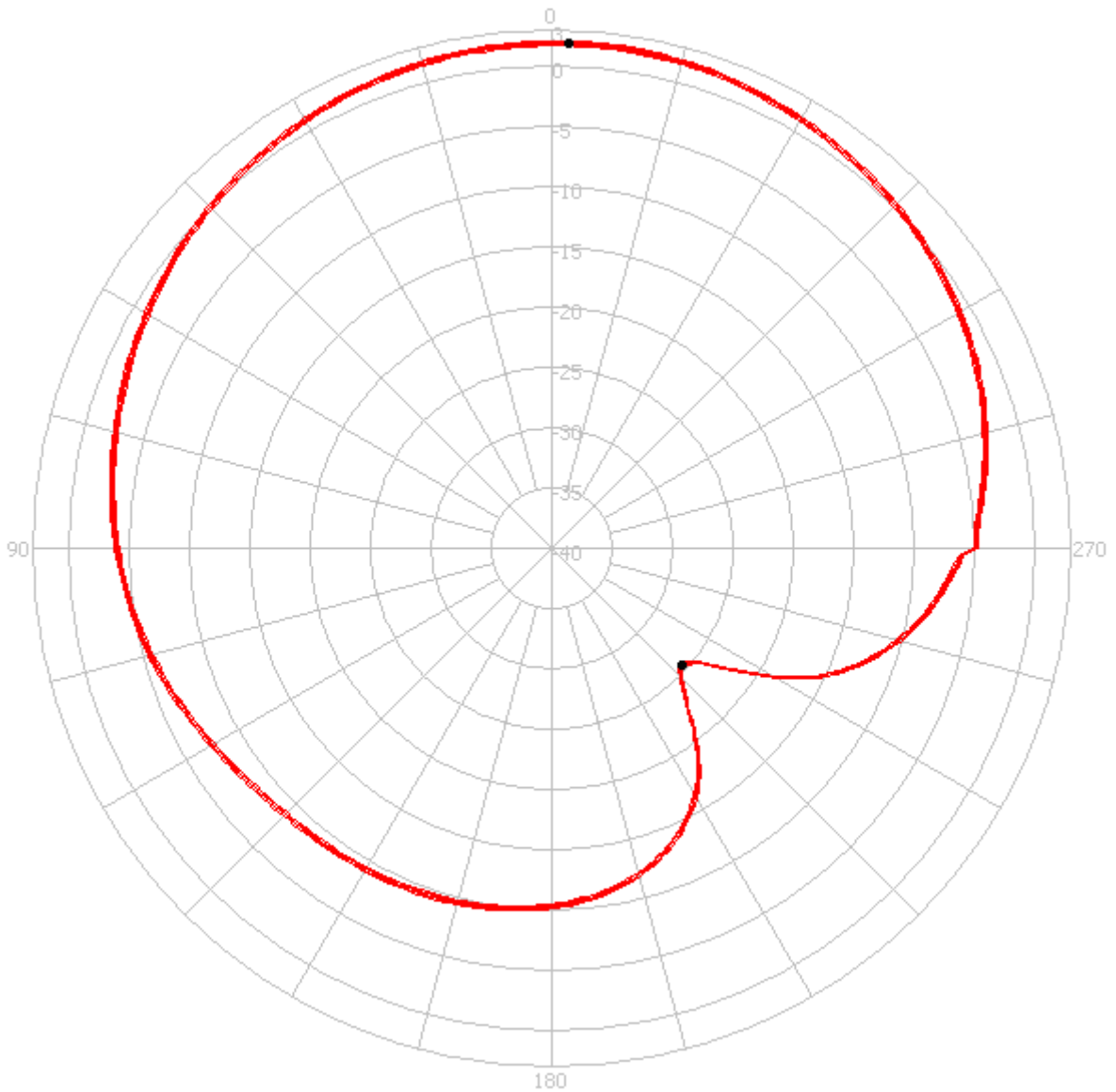

Test Mode	Freq (MHz)	Max Gain (dBi)	Min Gain (dBi)	Avg Gain (dBi)	Source Polar.
XZ	1575.42	-1.92 / 358	-25.43 / 228	-2.49	RHCP

## Y - Z Plane

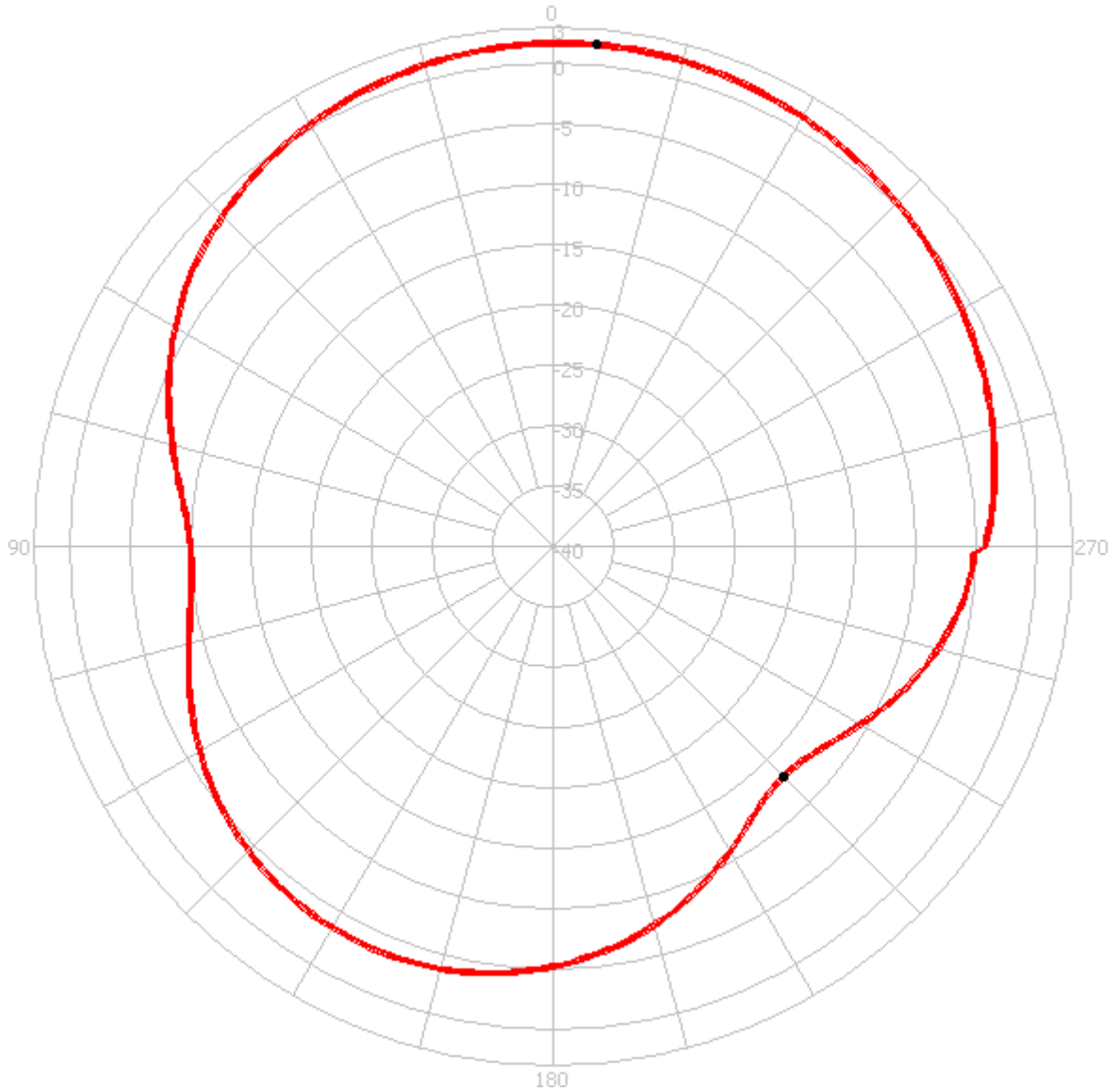

Test Mode	Freq (MHz)	Max Gain (dBi)	Min Gain (dBi)	Avg Gain (dBi)	Source Polar.
YZ	1575.42	-1.71 / 355	-13.07 / 225	-2.53	RHCP

# 4. Mechanical Specifications

## 4.1 Dimensions and Drawing

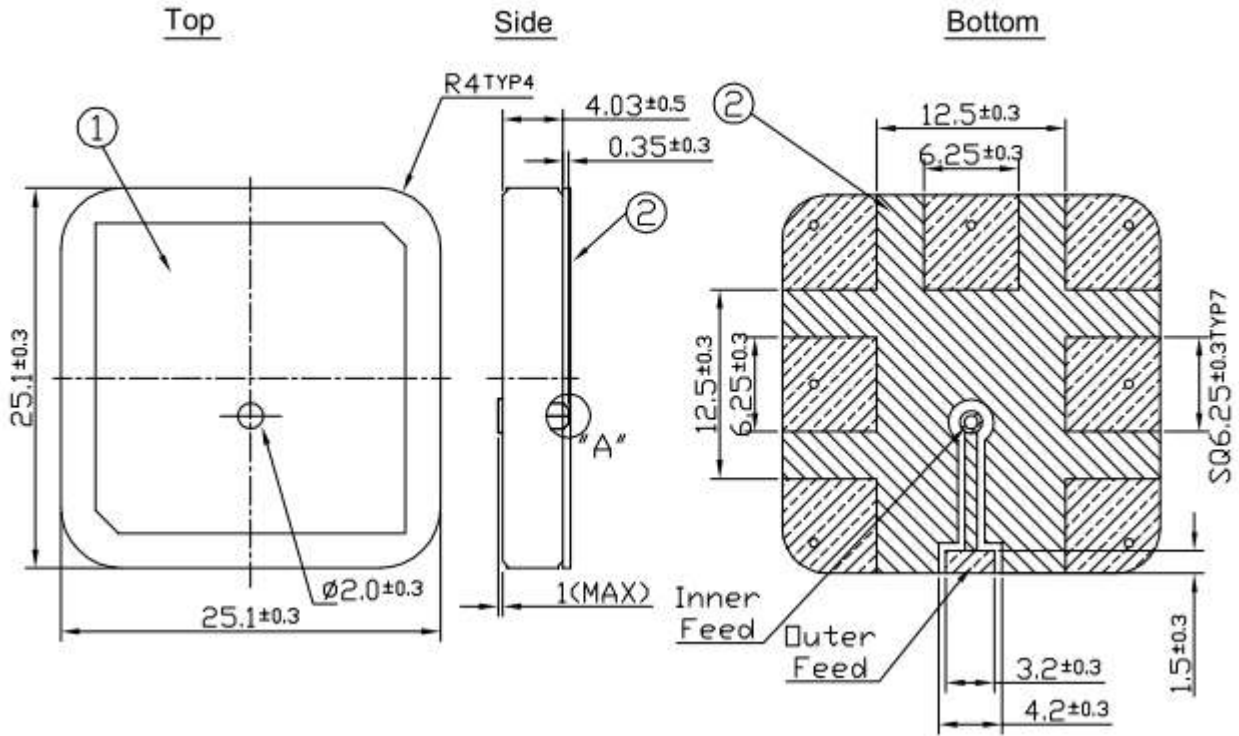

**NOTE:**

1. Solder mask
2. Area to be soldered
3. Dimension of 50 Ohm CPW dependent on individual board.
4. Matching circuit-capacitor and inductor values dependent on individual environment.
5. Must be soldered to complete antenna feed connection.



**PCB Footprint**

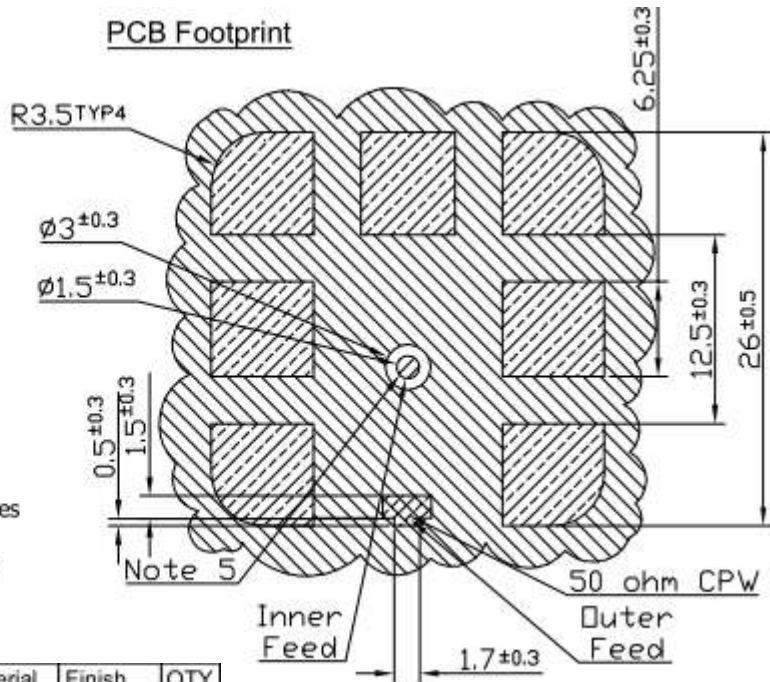

	Name	Part no.	Material	Finish	QTY
1	SGP.25 Patch 25x25x4	SGP.25D	Ceramic	Clear	1
2	SGP.25 PCB		FR 0.5t	Green	1



## 4.2 Test Fixture and Measurements

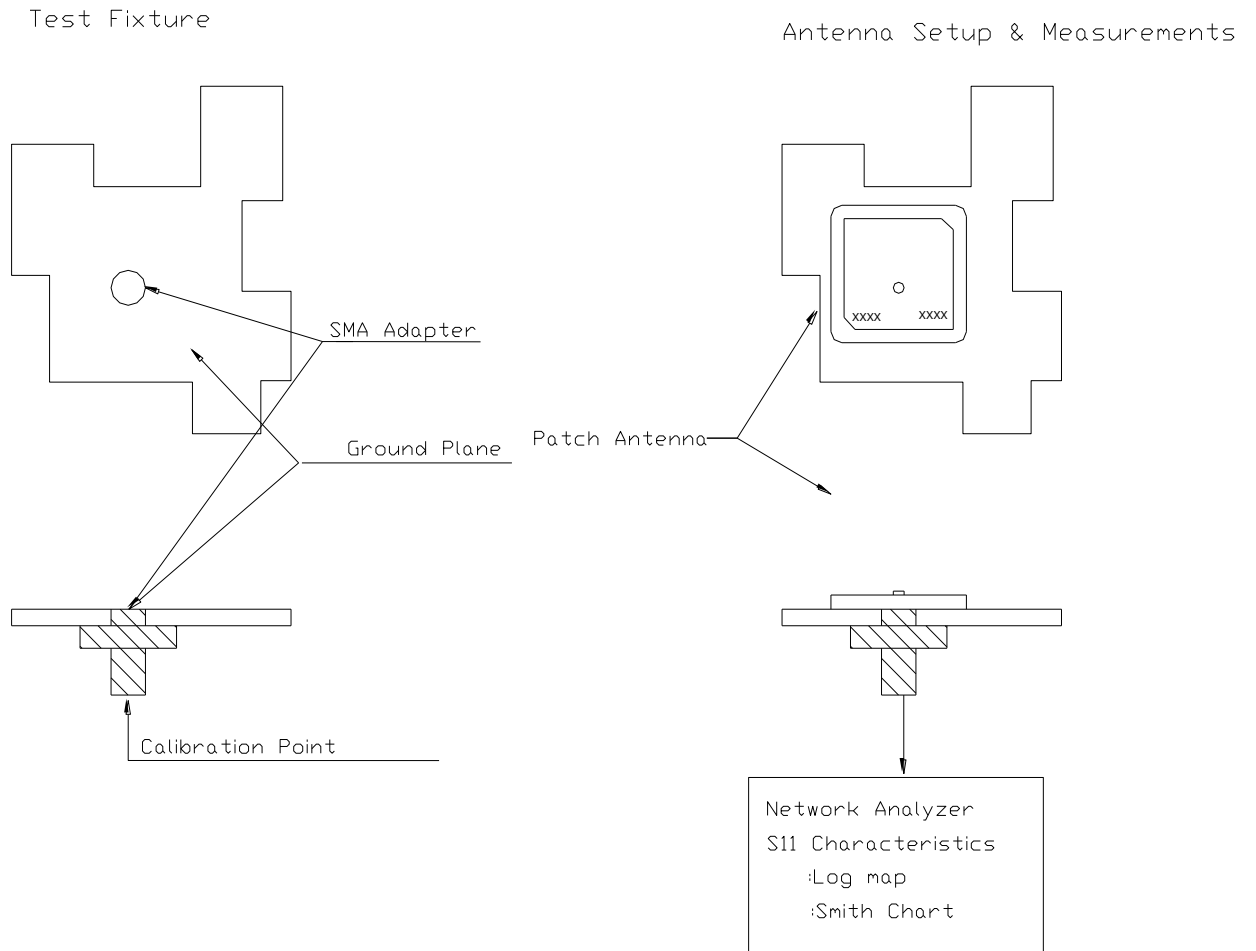

## 5. Antenna Recommended Soldering Conditions

### 5.1 Flux, Solder

- Use rosin-based flux. Don't use highly acidic flux with halide content exceeding 0.2wt%(chlorine conversion value).
- Use Sn solder.

### 5.2 Reflow soldering conditions

- Pre-heating should be in such a way that the temperature difference between solder and product surface is limited to 150°C max. Cooling into solvent after soldering also should be in such a way that temperature difference is limited to 100°C max. Unwrought pre-heating may cause cracks on the product, resulting in the deterioration of products quality.

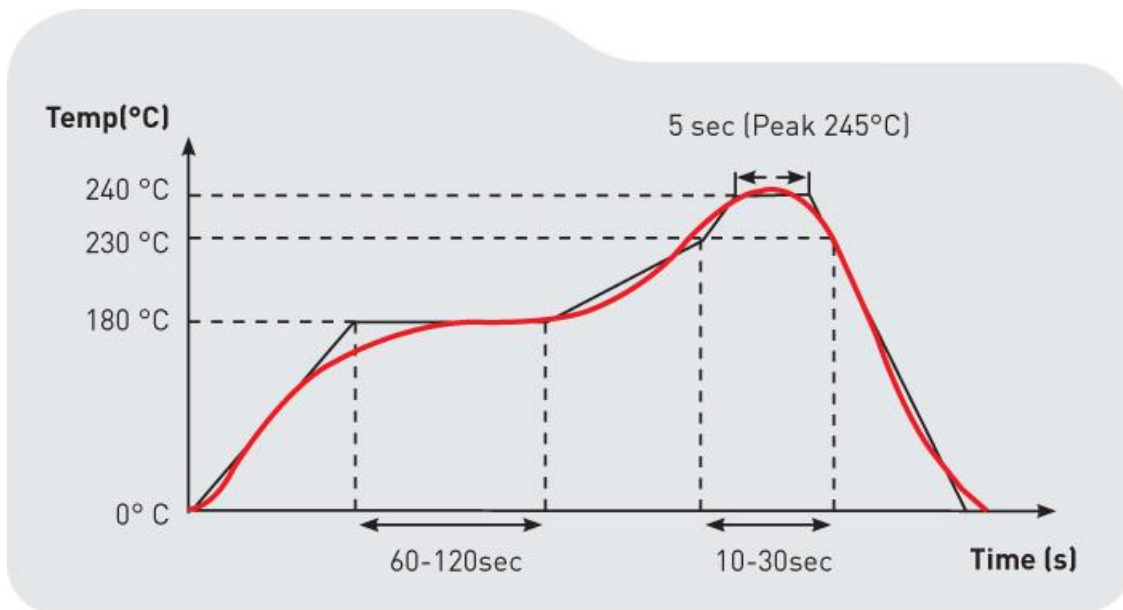

### 5.3 Reworking with soldering iron

- The following conditions must be strictly followed when using a soldering iron.

Pre-heating	150°, 1 min
Tip temperature	290° max
Soldering iron output	30w max
Soldering time	3 second max

## 6. Packaging

200 pieces/Reel/Inner carton,  
4 reels in outer carton - (800)

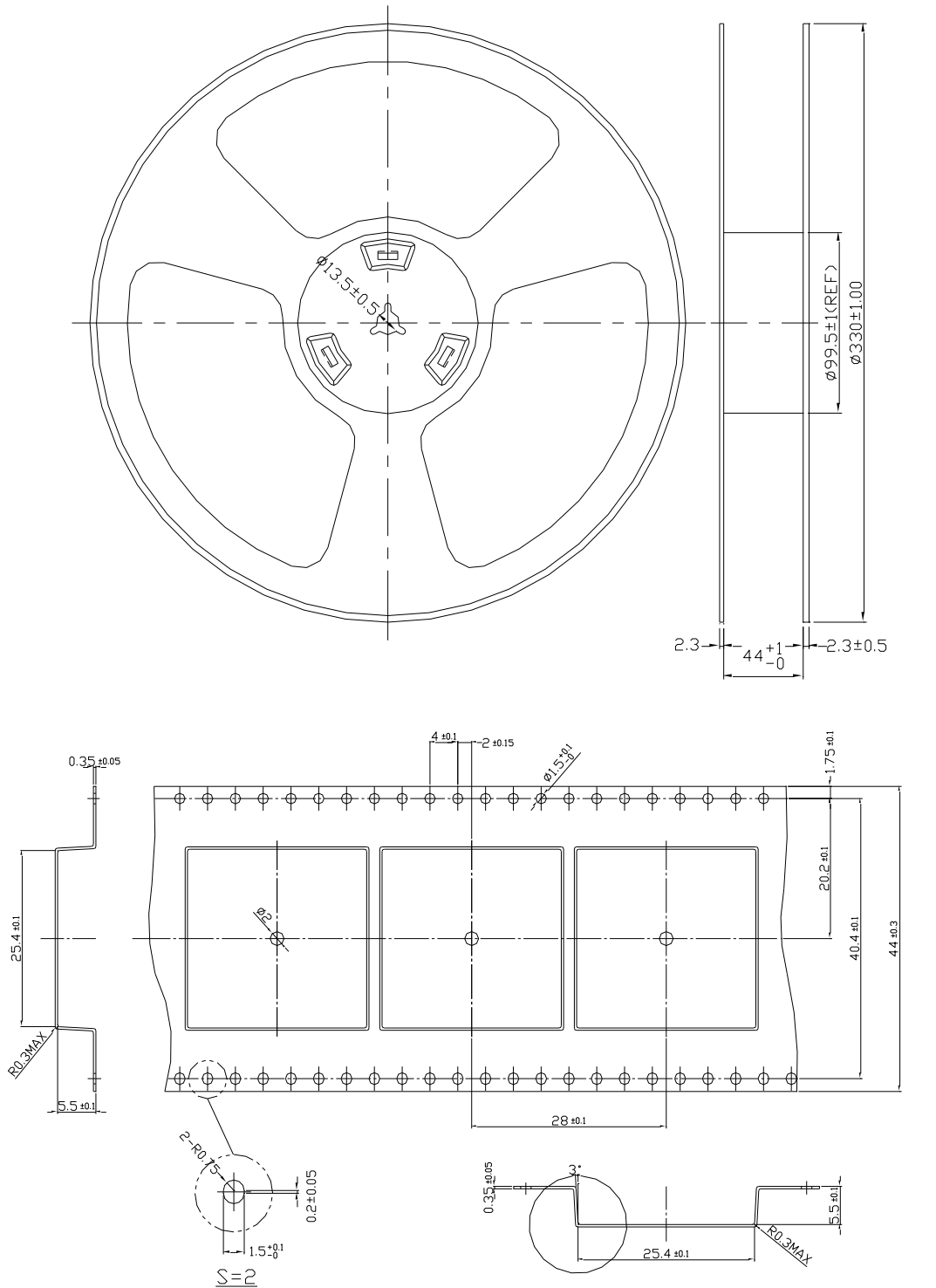

Unit: mm