

REVISIONS			
REV	DESCRIPTION, ECN, EAR NO.	DATE	APP'D
A	PROPOSAL	MAR 14/12	A.G
B	REMOVE KEY FEATURE PER P/N.	SEP 29/12	L.CHAN
C	SPECIFIC THE SHIELDED DRAWING.	APR 10/14	L.CHAN
D	FIX THE ERROR PER ECN 16089B	JAN 03/17	L.CHAN

1. MATERIALS:  
 PLASTIC HOUSING: THERMOPLASTIC PER MATERIAL OPTION IN PART NO.  
 FLAMMABILITY RATING UL 94V-0  
 COLOUR: BLACK

CONTACTS: PHOSPHOR BRONZE  
 PLATING: REFER TO PART NO. FOR GOLD THICKNESS ON MATING SURFACES.  
 50 u" [1.27 MICRONS]  
 MIN. NICKEL UNDERPLATE  
 100 u" [2.54 MICRONS]  
 MIN. MATTE TIN ON CONTACT TAILS.

SHIELD: STAINLESS STEEL WITH TIN DIPPED PCB TAILS.

AMPHENOL PART NUMBER: RJE74-1XX-1X10-X

NUMBER OF POSITION  
 8= 8 POSITION  
 A= 10 POSITION

NUMBER OF CONTACT  
 4= 4 CONTACT  
 6= 6 CONTACT  
 8= 8 CONTACT  
 A= 10 CONTACT

SHIELD OPTION  
 1= FULL SHIELD

GOLD PLATING  
 1 = 6u"      3 = 30u"  
 2 = 15u"     4 = 50u"

BLANK= PBT, TRAY PACKAGING, W/O MYLAR  
 A= HIGH TEMP. MATERIAL, TRAY PACKAGING, W/O MYLAR  
 H= HIGH TEMP. MATERIAL TAPE/REEL PACKAGING, WITH MYLAR

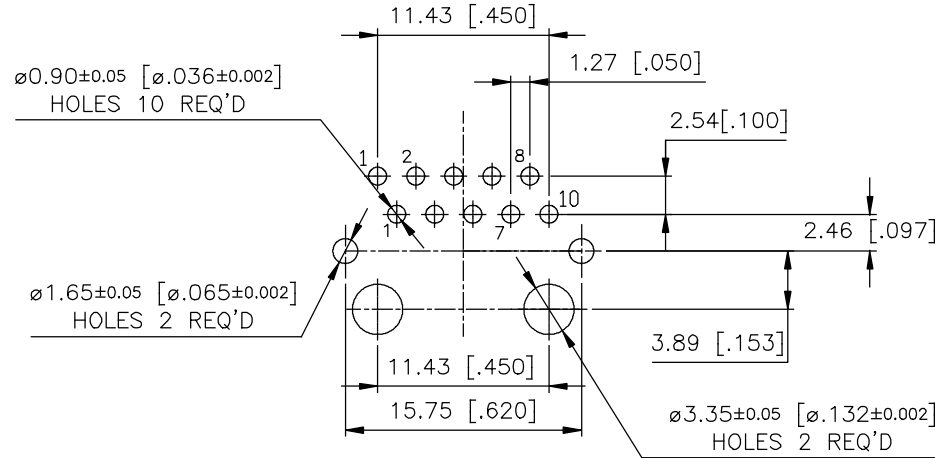

RECOMMENDED P.C.B LAYOUT  
 (COMPONENT SIDE OF BOARD  
 TOLERANCES: +/- 0.05[.002],  
 BASED ON PRODUCT WITH  
 SHIELD)

LOCATE HOLES  
 $\phi \pm 0.13 [0.005]$   
 POSITION DIMENSIONS  
 ARE BASIC

PART NUMBER	DIM A	DIM B	MYLAR OPTIONS
RJE74-1XX-1X10	16.61 [.654]	16.26 [.640]	WITHOUT MYLAR
RJE74-1XX-1X10-A	16.61 [.654]	16.26 [.640]	WITHOUT MYLAR
RJE74-1XX-1X10-H	16.7 [.657]	16.35 [.644]	WITH MYLAR



UNLESS SPECIFIED OTHERWISE	DRAWN	G.HSIA	MAR 15/12
PRIMARY UNITS MILLIMETERS	CHECKED		
SECONDARY INCHES	M.E. APP'D		
REFERENCE IN PARENTHESES	Q.A. APP'D		
GENERAL TOLERANCES	DWG APP'D	L.Chan	MAR 15/12
1 DECIMAL PLACE ±0.38	ENG. REL. NO.		
2 DECIMAL PLACES ±0.25	REF.		
3 DECIMAL PLACES			
ANGULAR DEGREES ±1.5°	THIRD ANGLE PROJECTION		
	DO NOT SCALE DRAWING		

Amphenol Canada Corp. www.amphenolcanada.com	
TITLE	MODULAR JACK, POSITION & CONTACT OPTION, WITH SHIELD, KAPTON TAPE OPTION, -RoHS COMPLIANT
DWG NO.	P-RJE74-1AA-1X11-X
REV	D
CODE ID NO.	03554
DWG SIZE:	C
SCALE:	N/A
SHEET	1 OF 2



REVISIONS			
REV	DESCRIPTION, ECN, EAR NO.	DATE	APP'D
A	PROPOSAL	MAR 14/12	A.G
B	REMOVE KEY FEATURE PER P/N.	SEP 29/12	L.CHAN
C	SPECIFIC THE SHIELDED DRAWING.	APR 10/14	L.CHAN
D	FIX THE ERROR PER ECN 16089B	JAN 03/17	L.CHAN

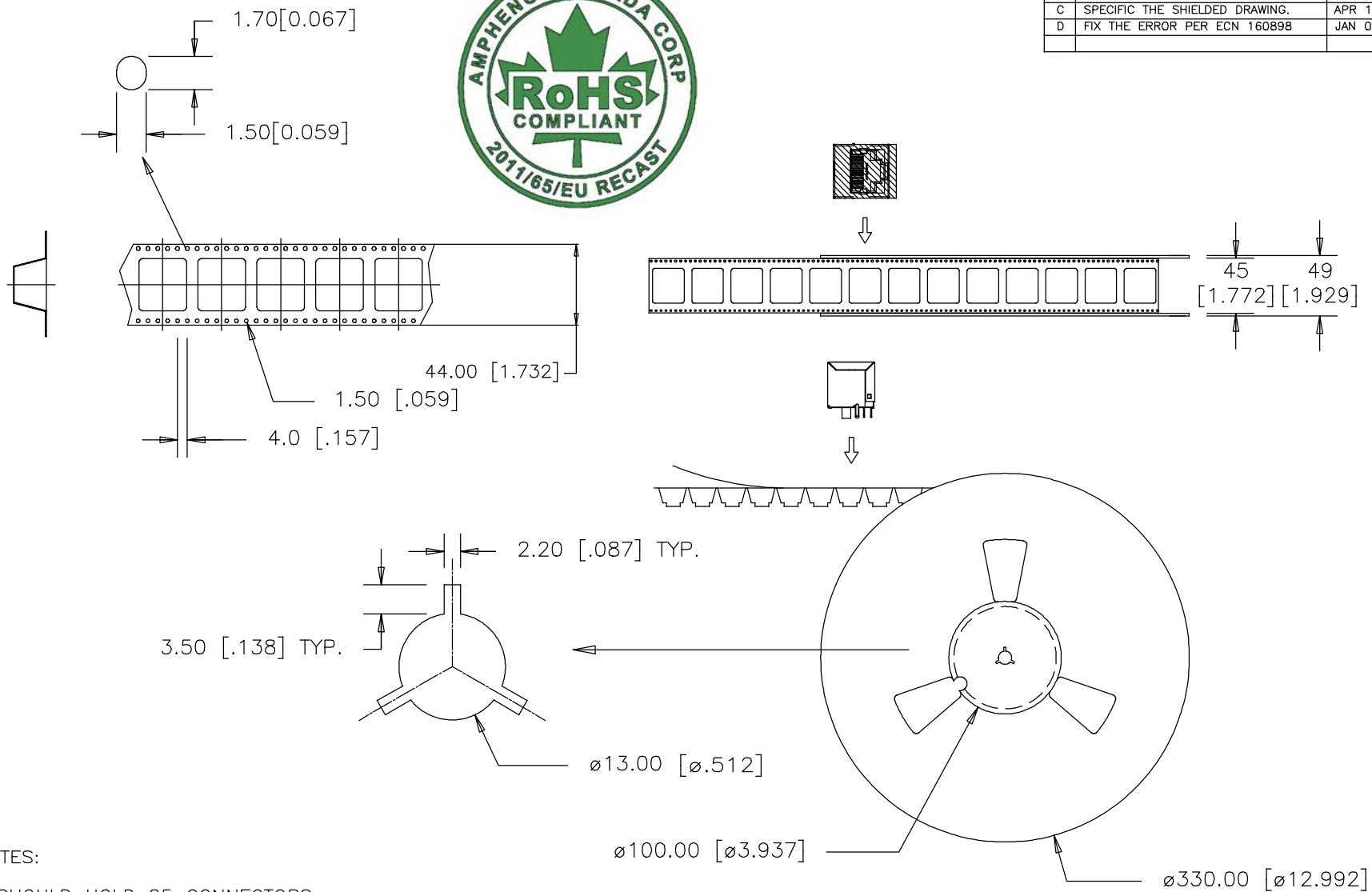

PACKAGING NOTES:

1. ONE REEL SHOULD HOLD 85 CONNECTORS.
2. 10 EMPTY CAVITIES FOR BOTH TOP AND BOTTOM OF THE CARRIER.
3. A FULLY LOADED CARTON SHOULD CONTAIN 5 REELS (425 PCS ) OF CONNECTOR.

UNLESS SPECIFIED OTHERWISE	DRAWN	G.HSIA	MAR 15/12
PRIMARY UNITS MILLIMETERS	CHECKED		
SECONDARY INCHES	M.E. APP'D		
REFERENCE IN PARENTHESES	Q.A. APP'D		
GENERAL TOLERANCES	DWG APP'D	L.Chan	MAR 15/12
1 DECIMAL PLACE $\pm 0.38$	ENG. REL. NO.		
2 DECIMAL PLACES $\pm 0.25$	REF.		
3 DECIMAL PLACES $\pm 0.15$	THIRD ANGLE PROJECTION		
ANGULAR DEGREES $\pm 1.5^\circ$	DO NOT SCALE DRAWING		

Amphenol Canada Corp. www.amphenolcanada.com	
TITLE MODULAR JACK, POSITION & CONTACT OPTION, WITH SHIELD, KAPTON TAPE OPTION, -RoHS COMPLIANT	
DWG NO. P-RJE74-1AA-1X11-X	REV D
CODE ID NO. 03554	DWG SIZE: C
SCALE: N/A	SHEET 2 OF 2