

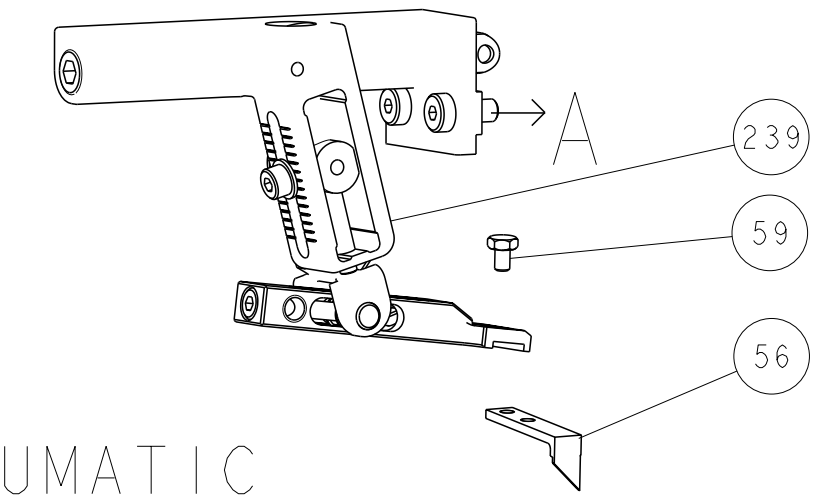

LOC	DIST	REVISIONS					
A	66	P	LYR	DESCRIPTION	DATE	OWN	APVD
		-		SEE SHEET 1	-	-	-

# FEED TYPE MECHANICAL



## PNEUMATIC

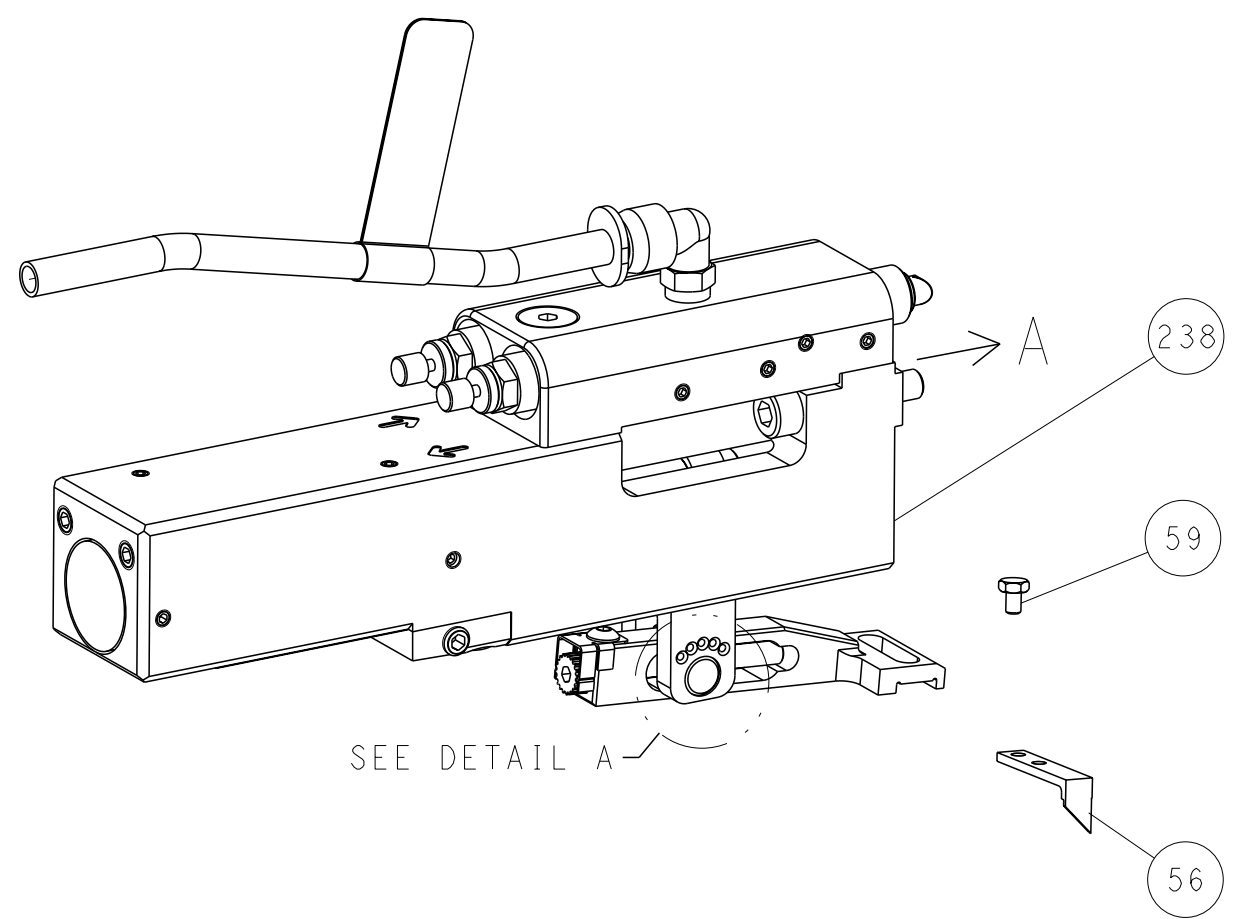

## FEED SPRING SETTING POSITION (SHOWN FROM REAR SIDE)

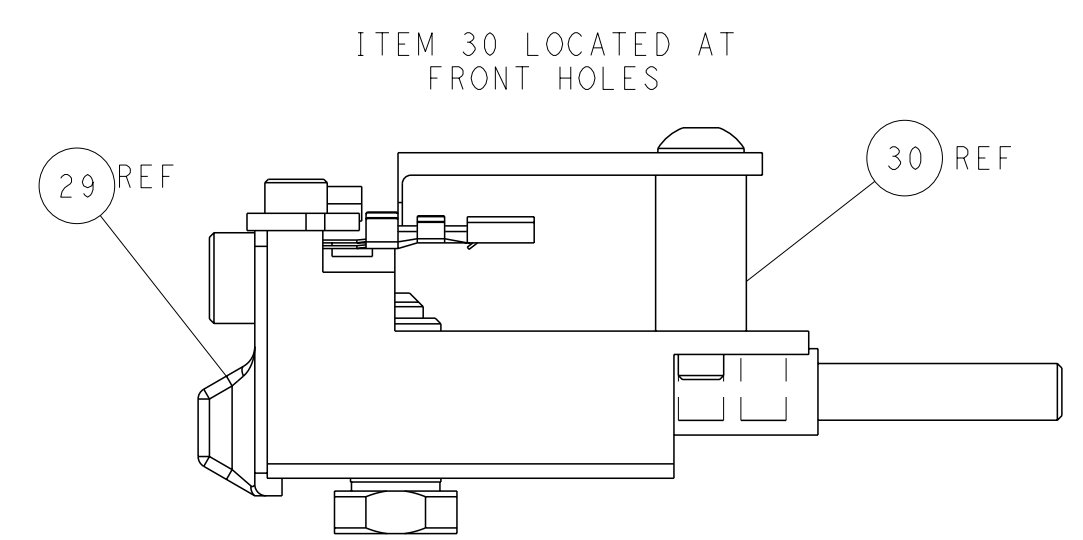
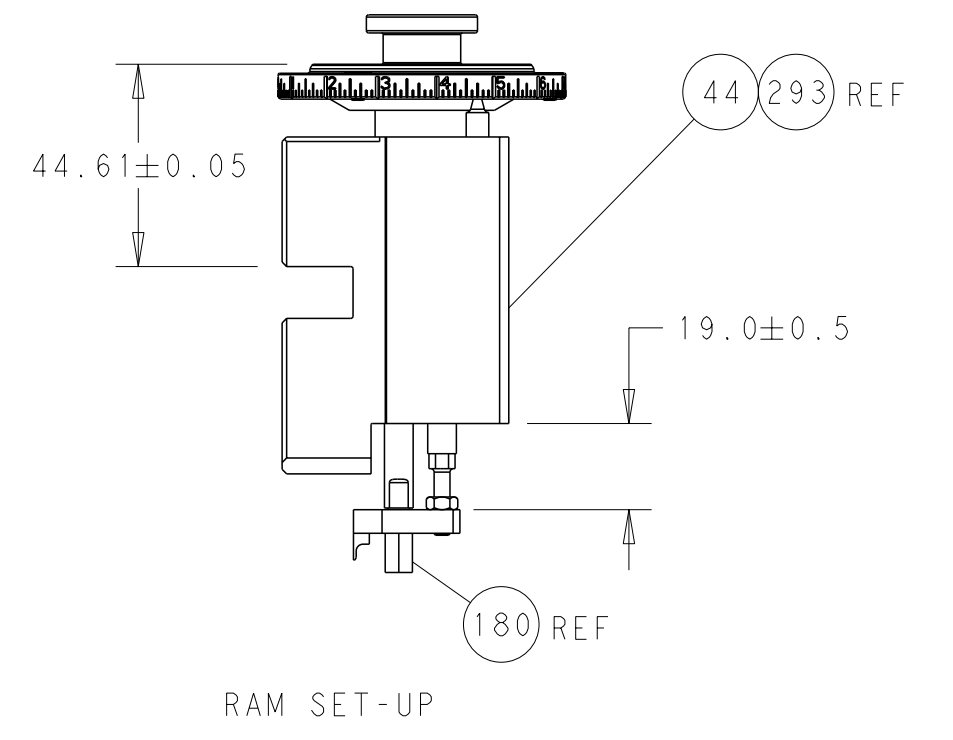
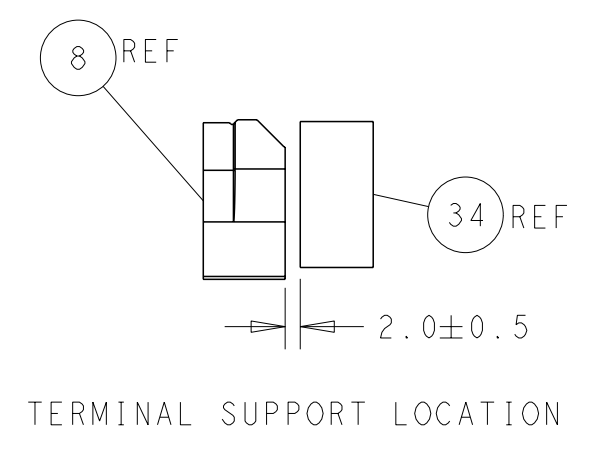
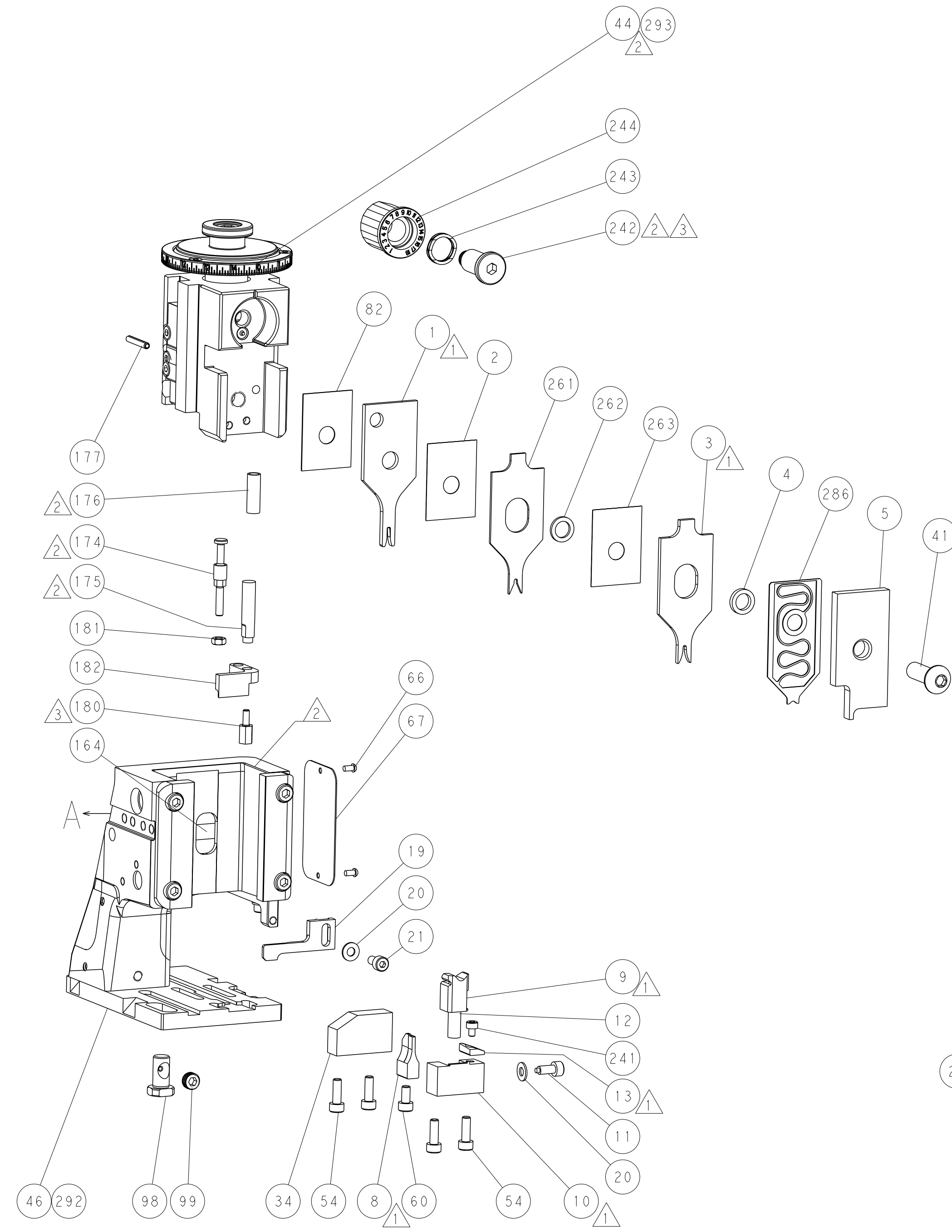
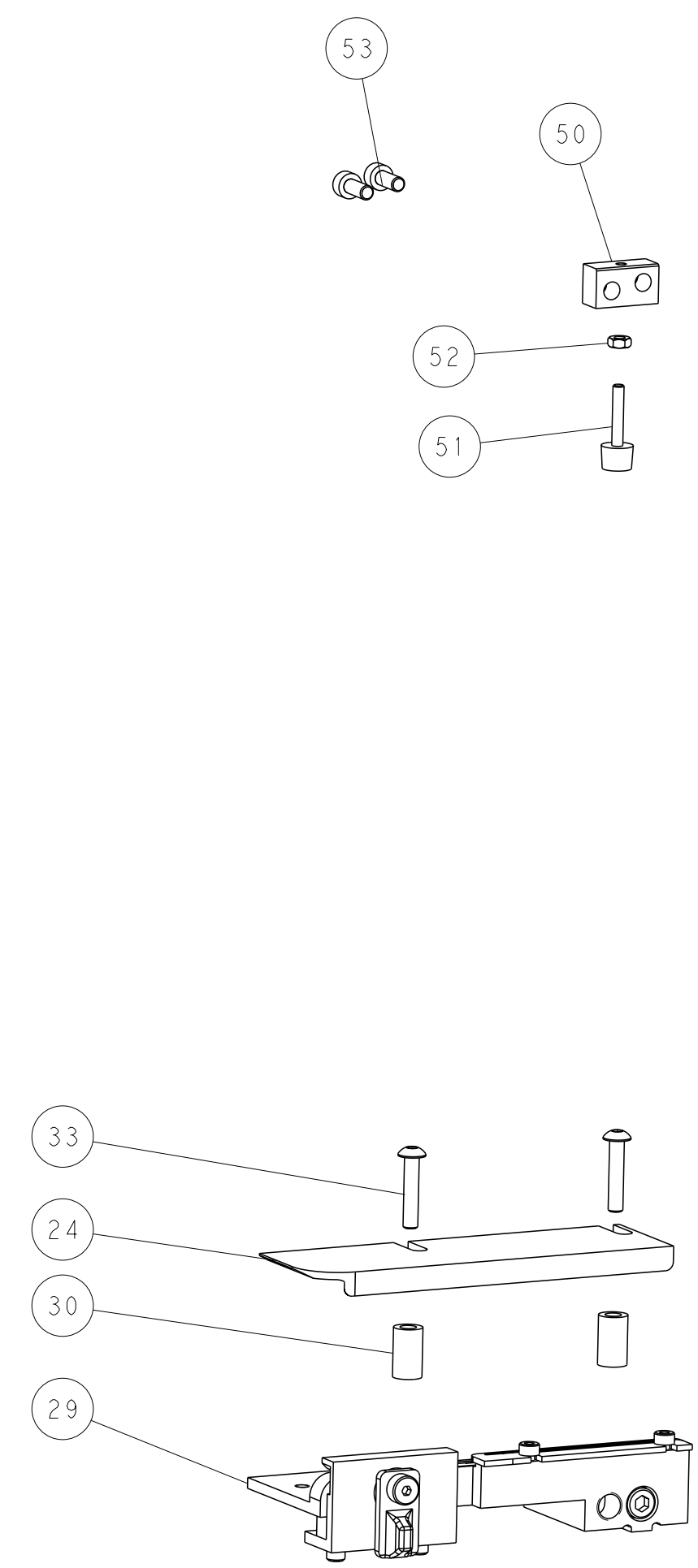
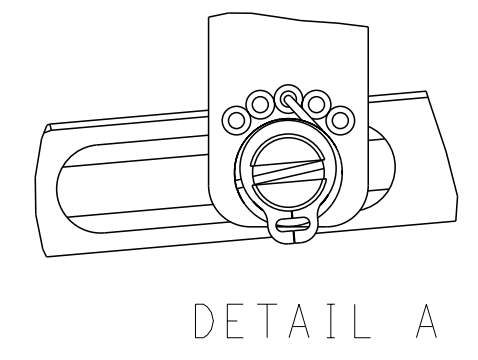

## CAM POSITIONS

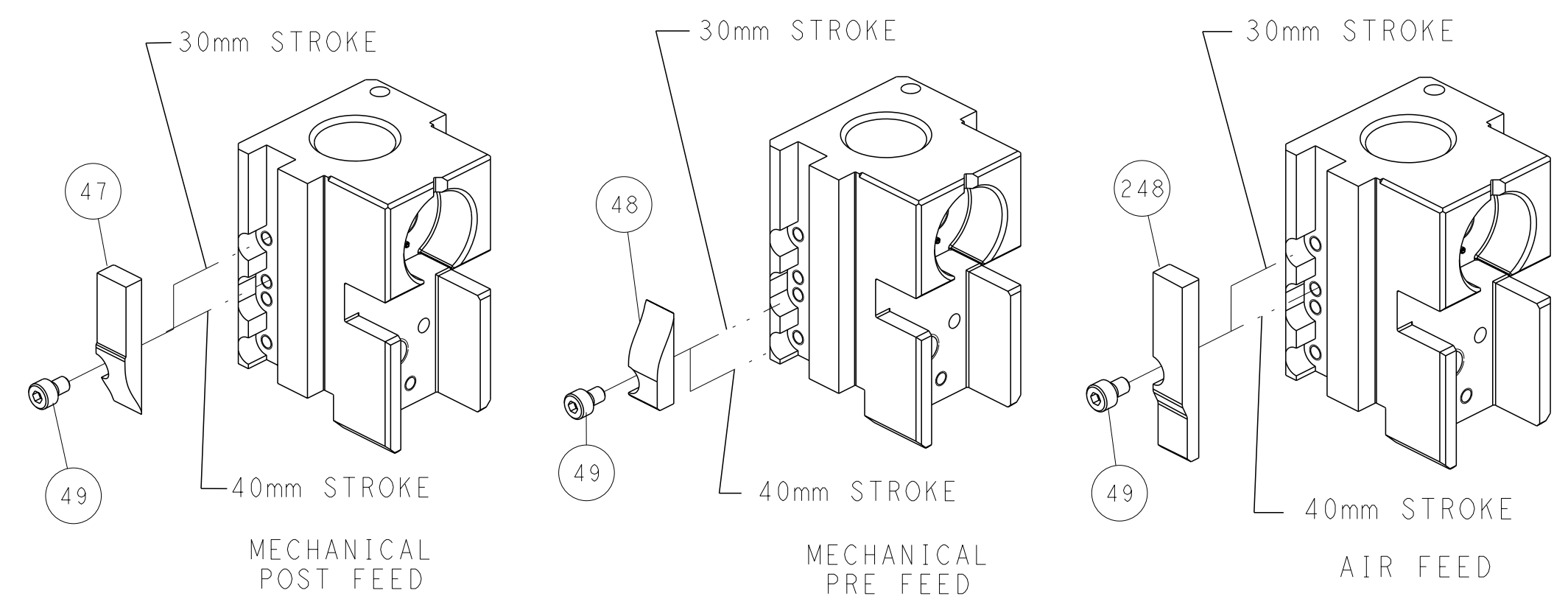

**ATLANTIC VERSION**  
 Shown on sheets 1 of 4 & 2 of 4  
 (Pacific version shown on sheets 3 of 4 & 4 of 4)

DIMENSIONS: mm TOLERANCES UNLESS OTHERWISE SPECIFIED: 0 PLC ± 1 PLC ± 2 PLC ± 3 PLC ± 4 PLC ± ANGLES ° ±		OWN: C. CHEN 20AUG2013 CHK: U. GUO 20AUG2013 APVD: J. CRUZ 20AUG2013 PRODUCT SPEC APPLICATION SPEC WEIGHT: - CUSTOMER DRAWING	NAME: Ocean Side Feed Applicator SIZE: A1 CAGE CODE: 00779 DRAWING NO: C=2266021 SCALE: 1:2 SHEET: 2 of 4 REV: D	TE Connectivity Harrisburg, PA 17105-3608 RESTRICTED TO
---	--	---	--	---

THIS DRAWING IS UNPUBLISHED.	RELEASED FOR PUBLICATION		
© COPYRIGHT 20 BY TYCO ELECTRONICS CORPORATION. ALL RIGHTS RESERVED.	20		
PART NUMBER	REVISION	DESCRIPTION	FEED TYPE
2-2266021-1	D	FINE CRIMP HEIGHT ADJUST	MECHANICAL
2-2266021-2	D	FINE CRIMP HEIGHT ADJUST	PNEUMATIC
7-2266021-7	A	CRIMP TOOLING KIT	-

PACIFIC VERSION TERMINATOR INTERFACE ADAPTER

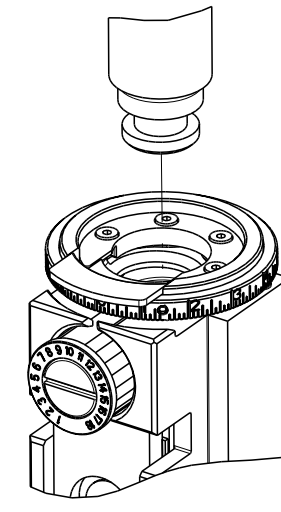

APPLICATOR DATA		
CRIMP	SIZE	TYPE
WIRE	1.40 mm [.055]	F
STAB	1.78 mm [.070]	O
INSUL	1.78 mm [.070]	O
APPLICATOR INSTRUCTIONS 408-35042		

TERMINAL DATA: TE TERMINAL		TE CRIMP SPECIFICATION	
TERMINAL NAME: CONTACT-LOCKING CLIP			
WIRE STRIP LENGTH		INSULATION DIAMETER RANGE	
3.58-4.34 mm [.141-.171 IN]		Ø0.96-1.57 mm [.038-.062 IN]	
TERMINAL APPLICATION SPECIFICATION	114-25006/6	-	-
TERMINALS APPLIED/6			
TE TERMINAL	TE TERMINAL	TE TERMINAL	TE TERMINAL
87124-1	87124-2	87124-3	5-87124-2
2267356-1			

TERMINAL DATA: TE TERMINAL		TE CRIMP SPECIFICATION	
TERMINAL NAME: CONTACT-LOCKING CLIP			
WIRE STRIP LENGTH		INSULATION DIAMETER RANGE	
3.58-4.34 mm [.141-.171 IN]		Ø1.27-2.54 mm [.050-.100 IN]	
TERMINAL APPLICATION SPECIFICATION	114-25006/6	-	-
TERMINALS APPLIED/6			
TE TERMINAL	TE TERMINAL	TE TERMINAL	TE TERMINAL
867052-1	867052-2	5-867052-1	

WIRE SIZE	CRIMP HEIGHT mm [INCH]	CRIMP HEIGHT REFERENCE SETTING	STABILIZER CRIMP HEIGHT mm [INCH]	TE HOUSING
22 AWG	0.86 +/- 0.05 [.034 +/- .002]	7.9	2.08 +/- 0.10 [.0819 +/- .0039]	-
24 AWG	0.76 +/- 0.05 [.030 +/- .002]	8.9	2.08 +/- 0.10 [.0819 +/- .0039]	-
26 AWG	0.76 +/- 0.05 [.030 +/- .002]	9.0	2.08 +/- 0.10 [.0819 +/- .0039]	-

WIRE SIZE	CRIMP HEIGHT mm [INCH]	CRIMP HEIGHT REFERENCE SETTING	STABILIZER CRIMP HEIGHT mm [INCH]	TE HOUSING
20 AWG	1.02 +/- 0.05 [.040 +/- .002]	6.1	2.08 +/- 0.10 [.0819 +/- .0039]	-

**\*WARNING**  
ON INSTALLATION, SET WIRE DISC TO CRIMP HEIGHT REFERENCE SETTING FOR LARGEST WIRE SIZE. CRIMP HEIGHT REFERENCE SETTINGS GREATER THAN THE VALUE SHOWN MAY CAUSE DAMAGE TO THE CRIMP TOOLING. REFER TO THE INSTRUCTION SHEET FOR PROPER SETUP AND ADJUSTMENTS.

- 1. RECOMMENDED SPARE PARTS
- 2. REFER TO SUPPLIED INSTRUCTION SHEET FOR CLEANING, LUBRICATION AND STORAGE OF APPLICATOR.
- 3. APPLY PART NUMBER 2-23419-6 LOCTITE TO THREADS OF ITEM 242.
- 4. CRIMP HEIGHT REFERENCE SETTING WAS THE SETTING USED WHEN THE APPLICATOR WAS QUALIFIED AT THE FACTORY. ADJUSTMENT MAY BE NECESSARY WHEN RUNNING APPLICATOR IN THE FIELD.
- 5. UNLESS SPECIFIED OTHERWISE TORQUE VALUES SHALL BE USED PER DOCUMENT, 101-35000.
- 6. APPLICATOR WAS QUALIFIED TO STABILIZER CRIMP HEIGHT LISTED FOR ALL TERMINALS AND HOUSING COMBINATION ONLY. APPLICABLE HOUSINGS: 926657, 926209, 926659, AND 926663.

LOC	DIST	REVISIONS					
A	66	P	LYH	DESCRIPTION	DATE	OWN	APVD
		-		SEE SHEET 1	-	-	-

-	1	1	2119791-5	DEPRESSOR, WIRE	286
-	1	1	455888-1	SPACER, CRIMPER	263
-	1	1	2-238011-0	BLOCK, CRIMPER SPACER	262
1	1	1	4-1803019-1	CRIMPER, INSULATION O	261
-	1	1	2119082-5	CAM, SNAIL, INSULATION ADJUSTMENT	244
-	1	1	2079764-1	WASHER, WAVE SPRING, CREST-TO-CREST	243
-	1	1	2119083-1	RETAINER, INSULATION DIAL	242
-	1	1	7-18023-7	SCR, SKT HD CAP M3 X 4.0	241
-	-	1	2119580-1	MECHANICAL FEED ASSEMBLY	239
-	1	-	2844940-1	AIR FEED MODULE	238
-	REF	REF	994970-2	COUNTER, MAGNETIC	164
-	1	-	2119641-2	FEED CAM, AIR FEED	151
-	1	1	2168083-8	SCR, SKT HD CAP, RoHS, M4 X 16	144
-	4	4	2168083-9	SCR, SKT HD CAP, RoHS, M4 X 20	143
-	-	1	2119653-2	FEED CAM, POST FEED	142
-	1	1	1-1803583-0	APPLICATOR BASIC ASSEMBLY, SF	141
-	1	1	1803516-1	RAM ASSEMBLY, SF PACIFIC	140
-	1	1	2844908-1	SCREW, LOCKING	99
-	1	1	2844907-1	POST, LOCKING	98
-	1	1	455888-4	SPACER, CRIMPER	82
-	1	1	1803607-3	DOCUMENTATION PACKAGE	71
-	1	1	2119740-1	TAG, IDENTIFICATION	67
-	2	2	2168078-1	SCREW, DRIVE, RH, RoHS, 2 x .188	66
-	1	1	5-18022-5	SCR, HEX HD CAP, M4 X 6.0	59
-	1	1	1338685-1	PAWL, FEED	56
-	2	2	1-2168083-0	SCR, SKT HD CAP, RoHS, M4 X 10	53
-	1	1	5018030-1	NUT, HEX, REG, RoHS, M3	52
-	1	1	811242-5	BUMPER, HOLD DOWN	51
-	1	1	690753-2	SPACER, TONKER	50
-	1	2	18023-9	SCR, SKT HD CAP M4 X 6.0	49
-	-	1	2119652-1	FEED CAM, PRE FEED	48
-	1	1	1803602-1	SCR, BHSC, RoHS (M8 X 25)	41
-	1	1	3-1752356-4	SUPPORT, TERMINAL	34
-	2	2	2079383-5	SCR, BHSC, RoHS (M4 X 20)	33
-	2	2	2-2844962-4	SPACER, CYLINDRICAL, STRIP GUIDE	30
-	1	1	2844992-1	ASSEMBLY, STRIP GUIDE	29
-	1	1	1320928-2	STRIP GUIDE	24
-	1	1	2168083-2	SCR, SKT HD CAP, RoHS, M4 X 8.0	21
-	2	2	1-18028-2	WASHER, FLAT, REG M4	20
-	1	1	2119533-1	STRIPPER, SIDE FEED	19
-	1	1	2119806-1	INSERT, SHEAR	13
-	1	1	3-22280-3	SPRING, COMPRESSION	12
-	1	1	1-356885-4	STOP, SHEAR	11
-	1	1	2119805-1	SHEAR HOLDER, FRONT	10
-	1	1	1803095-6	FLOATING SHEAR, FRONT	9
1	1	1	1-1633917-8	ANVIL, COMBINATION	8
-	-	-	-	-	7
-	-	-	-	-	6
-	1	1	2119757-8	DEPRESSOR, SHEAR	5
-	1	1	1-238011-7	BLOCK, CRIMPER SPACER	4
1	1	1	9-2119784-3	CRIMPER, INSULATION O PREMIUM	3
-	1	1	455888-2	SPACER, CRIMPER	2
1	1	1	2-456402-5	CRIMPER, WIRE PREMIUM	1

DIMENSIONS:		TOLERANCES UNLESS OTHERWISE SPECIFIED:		OWN	20AUG2013	TE Connectivity Harrisburg, PA 17105-3608	
mm	0 PLC ±	2 PLC ±	3 PLC ±	CHK	20AUG2013		
	4 PLC ±	ANGLES	FINISH	APVD	20AUG2013		
MATERIAL				NAME			
CUSTOMER DRAWING		SCALE	1:2	SHEET	3 OF 4	REV	D

PACIFIC VERSION  
Shown on sheets 3 of 4 & 4 of 4  
(Atlantic version shown on sheets 1 of 4 & 2 of 4)

LOC		DIST		REVISIONS			
A	66	P	LYR	DESCRIPTION	DATE	OWN	APVD
		-		SEE SHEET 1	-	-	-

# FEED TYPE MECHANICAL

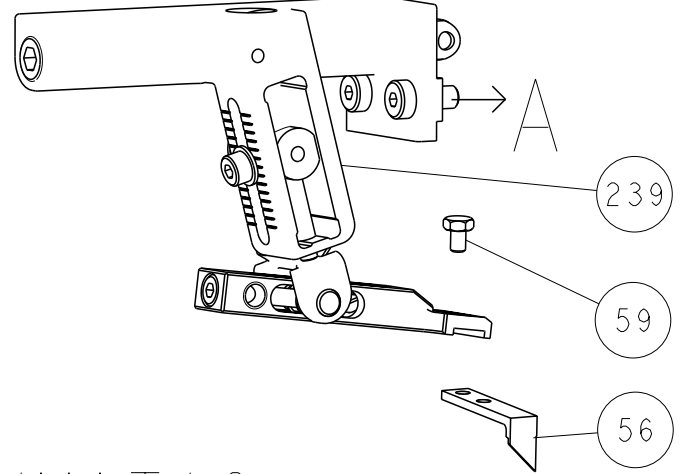

# PNEUMATIC

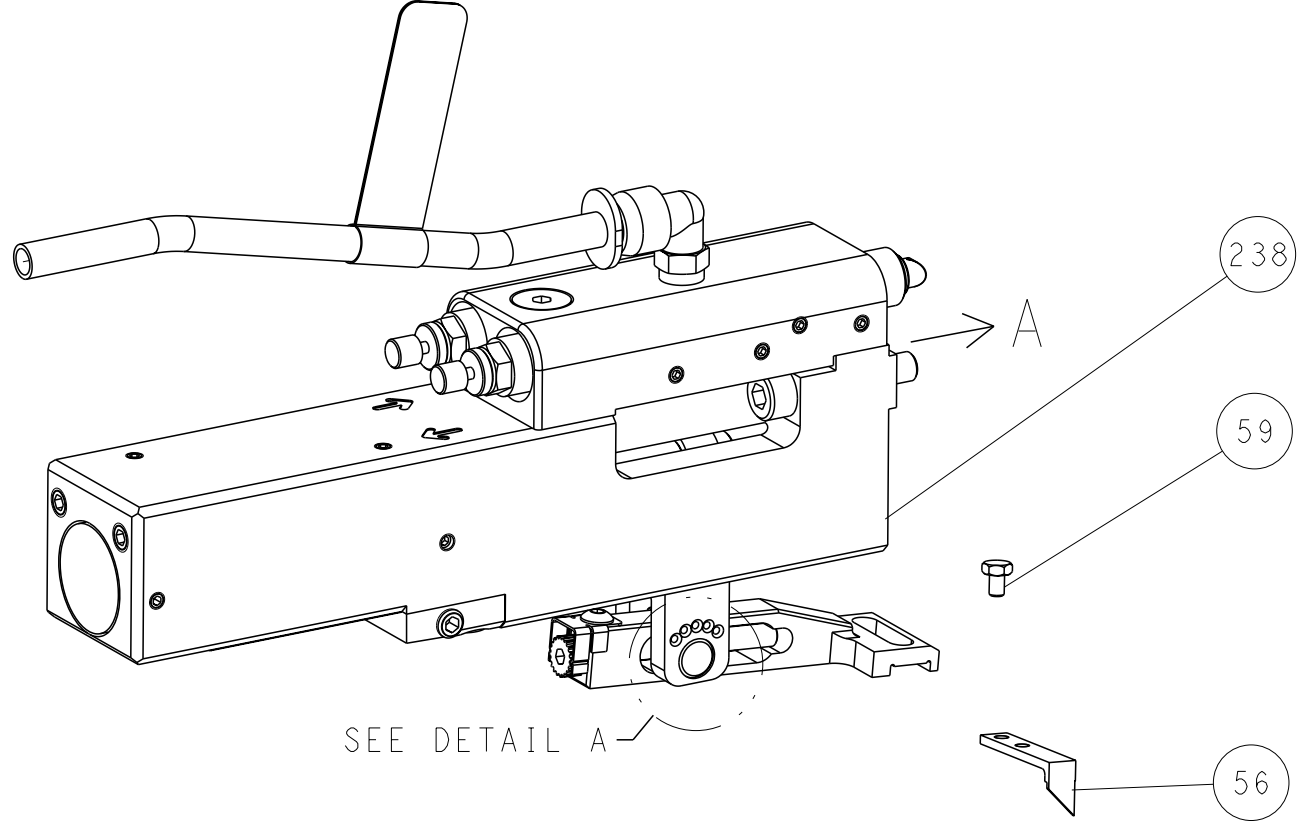

# FEED SPRING SETTING POSITION (SHOWN FROM REAR SIDE)

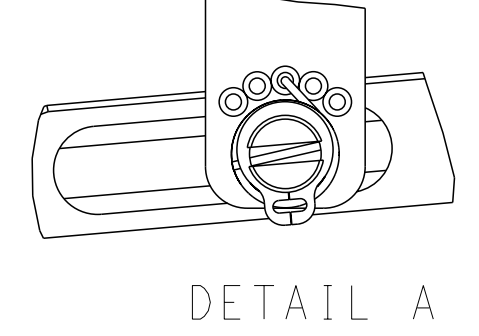

DETAIL A

# CAM POSITIONS

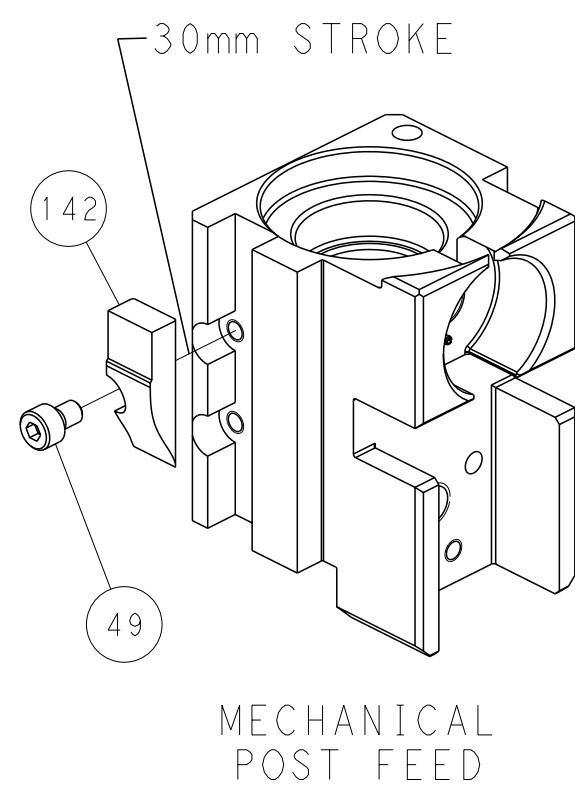

MECHANICAL  
POST FEED

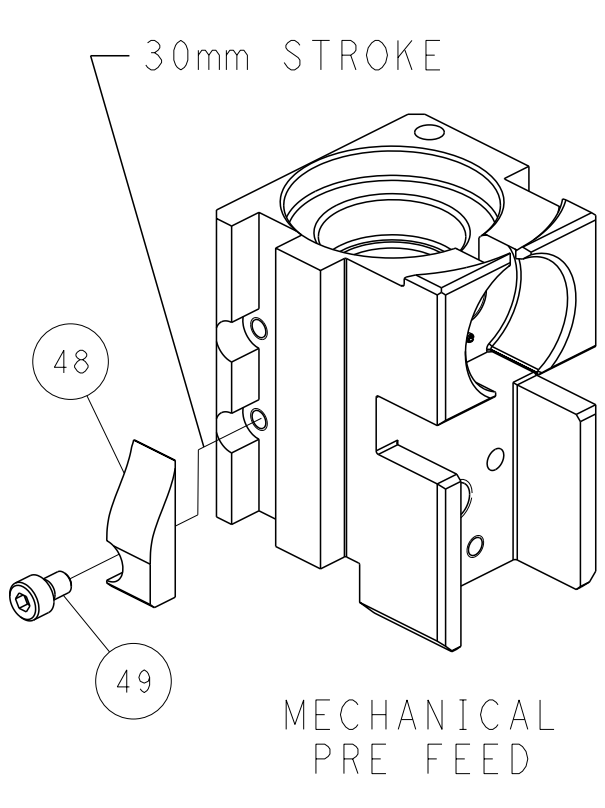

MECHANICAL  
PRE FEED

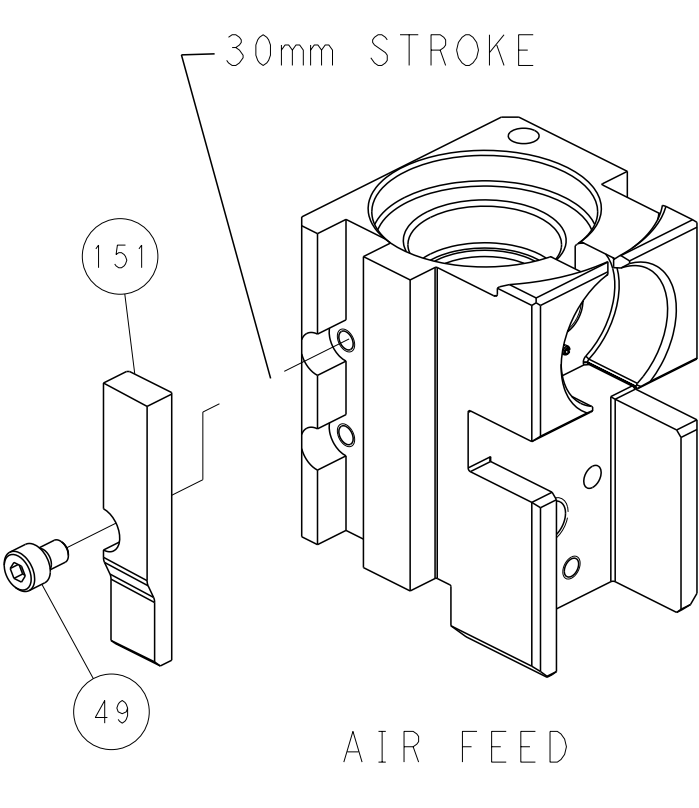

AIR FEED

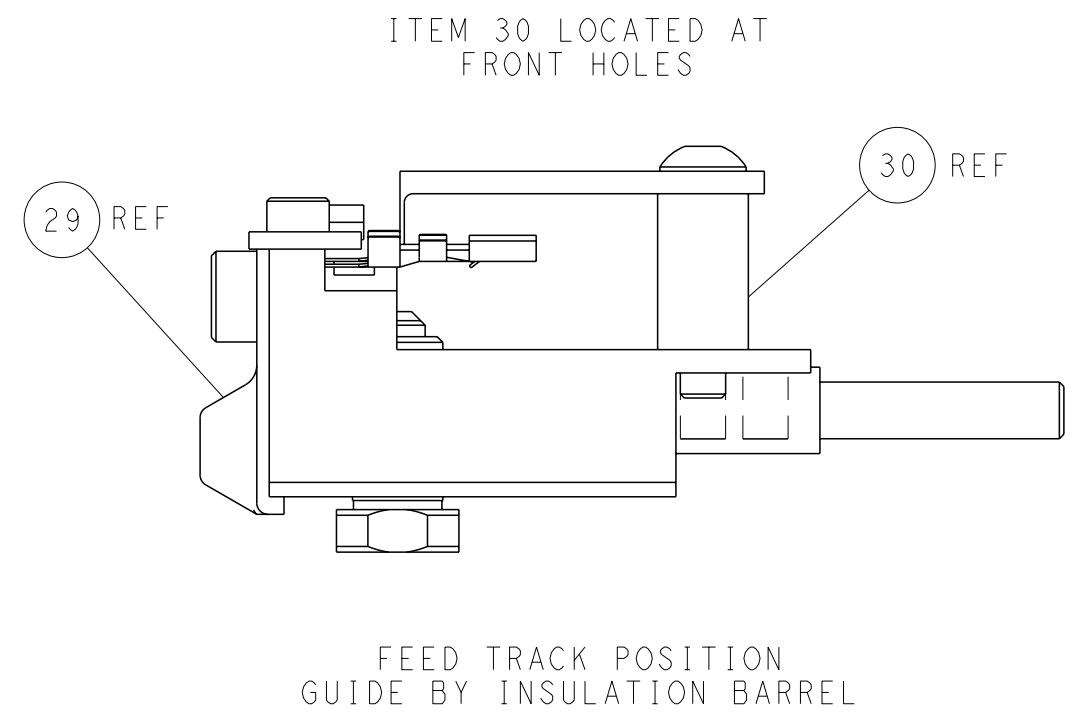
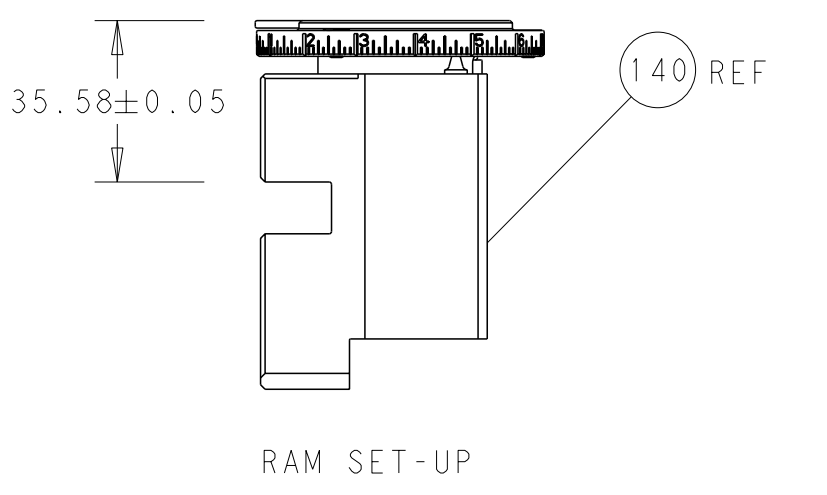
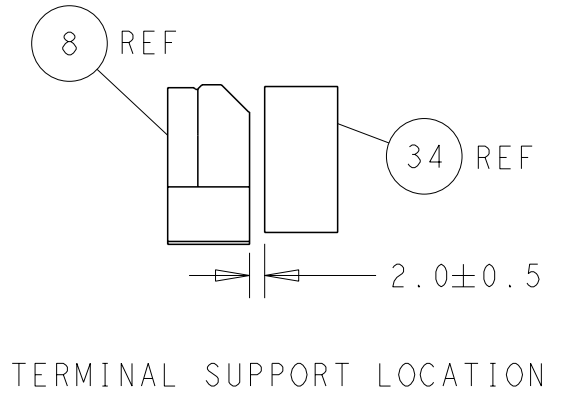
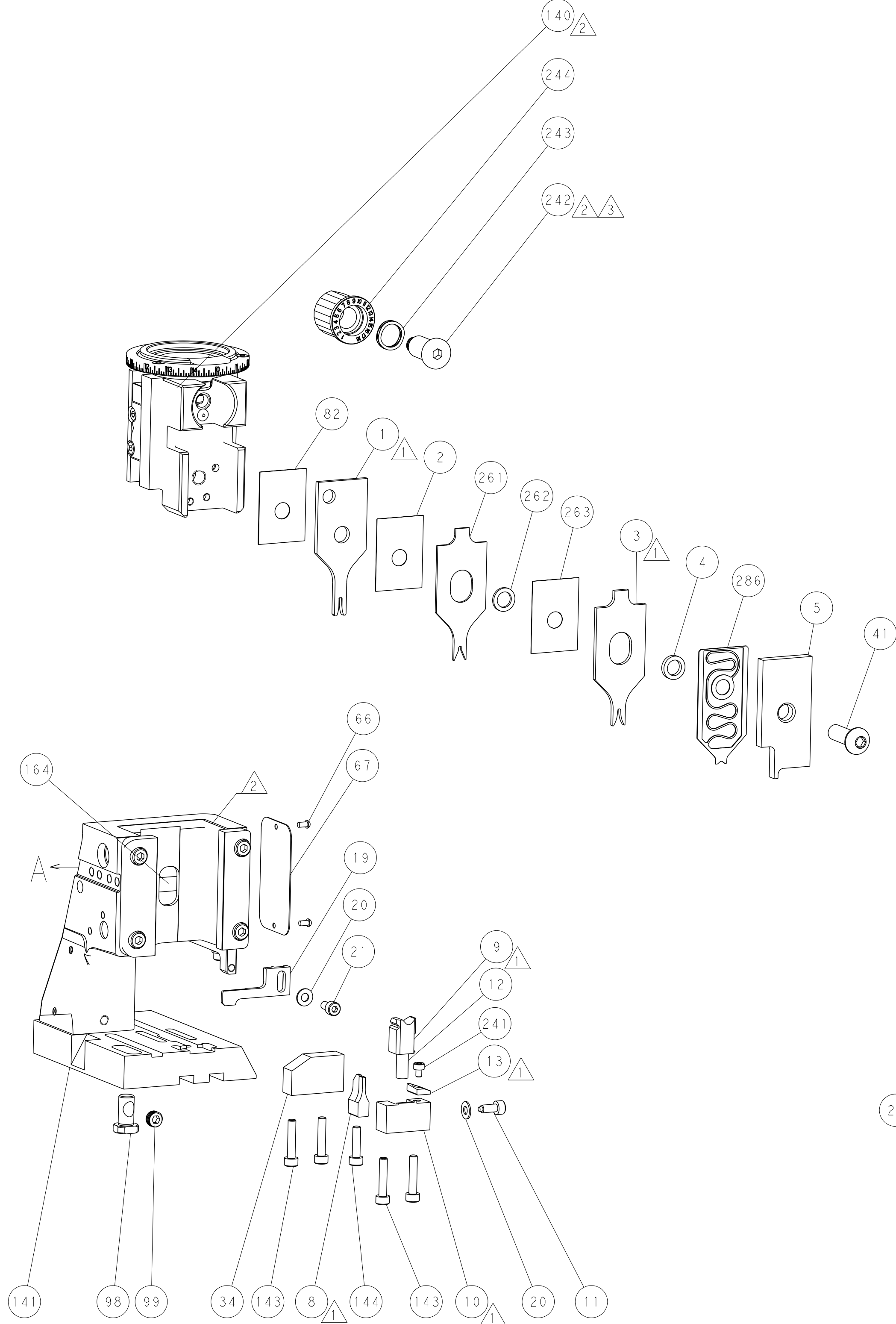
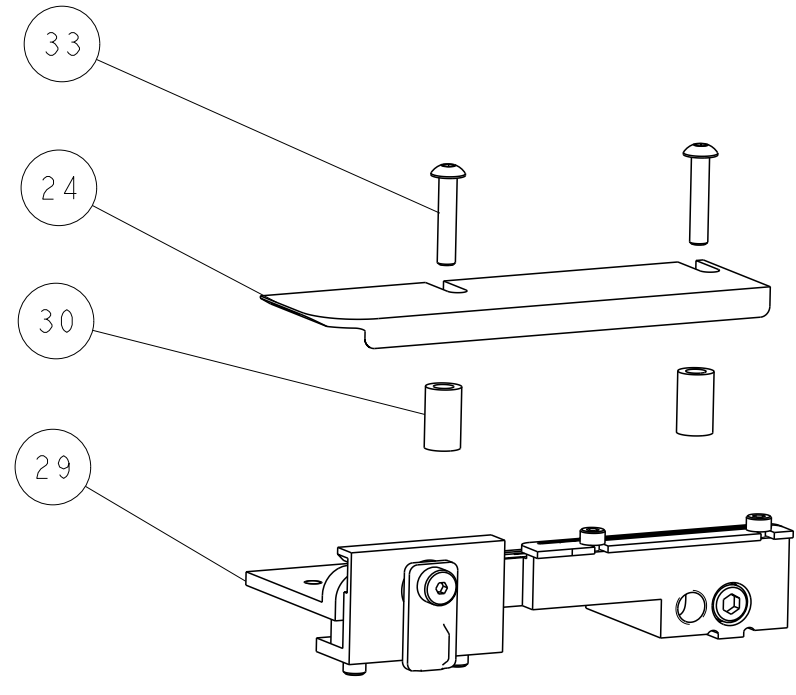

**PACIFIC VERSION**  
 Shown on sheets 3 of 4 & 4 of 4  
 (Atlantic version shown on sheets 1 of 4 & 2 of 4)

<small>THIS DRAWING IS A CONTROLLED DOCUMENT FOR TYCO ELECTRONICS CORPORATION. IT IS SUBJECT TO CHANGE AND THE CONTROLLING ENGINEERING ORGANIZATION SHOULD BE CONTACTED FOR THE LATEST REVISION.</small>		OWN: C. CHEN 20AUG2013 CHK: U. GUO 20AUG2013 APVD: J. CRUZ 20AUG2013	TE Connectivity Harrisburg, PA 17105-3608
DIMENSIONS: mm TOLERANCES UNLESS OTHERWISE SPECIFIED: 0 PLC ± 1 PLC ± 2 PLC ± 3 PLC ± 4 PLC ± ANGLES FINISH *	NAME: Ocean Side Feed Applicator SIZE: A1 CAGE CODE: 00779 DRAWING NO: C-2266021	RESTRICTED TO: - WEIGHT: - SCALE: 1:2 SHEET: 4 of 4 REV: D	CUSTOMER DRAWING