

TPS62770 Multi-Rail DC/DC Converter For Wearable Applications

1 Features

- VIN Range 2.5 V to 5.5 V
- 370 nA Iq Step-Down Converter
 - 8 Selectable Output Voltages (1.0V to 3.0V)
 - 300 mA Output Current
 - Output Discharge Function
- Slew Rate Controlled Load Switch with Discharge Function
- Dual Mode Step-Up Converter
 - Load Disconnect
 - Constant Output Voltage Adjustable up to 15 V (V_{FB} 0.8 V) / 12 V Fixed
 - LED Current Driver with PWM to Current Conversion (max V_{FB} Voltage 200 mV @ D = 100%)
- Tiny 16pin 1.58 x 1.58mm WCSP Package 0.4mm pitch

2 Applications

- Wearable and Personal Electronics
- Fitness Accessories
- Health Monitoring and Medical Accessories

3 Description

The TPS62770 is a tiny power solution for wearable applications including a 370nA ultra low Iq step-down converter, a slew rate controlled load switch and a dual mode step-up converter. The output voltage of the step-down converter can be selected with three VSEL pins between 1.0 V, 1.05 V, 1.1 V, 1.2 V, 1.8 V, 1.9 V, 2.0 V and 3.0 V. The output voltage can be changed during operation. In shutdown mode, the output of the step-down converter is pulled to GND. The integrated load switch is internally connected to the output of the step-down converter and features slew rate control during turn on phase. Once turned off, its output is connected to GND.

The dual mode step-up converter can generate a constant output voltage up to 15 V, such as PMOLED supply; or, a constant output current, such as LED back light supply. The output voltage can be adjusted up to 15 V with external resistors, or set to fixed 12 V by connecting the FB pin to VIN. The device features an internal over voltage protection of 17.7 V in case the FB node is left open or tight to GND. It includes an internal rectifier and load disconnect function. When used as constant output current driver, the device offers a PWM to analog converter to scale down the reference voltage according to the duty cycle of the PWM signal.

The device is available in a small 16pin 0.4mm pitch WCSP package.

Device Information⁽¹⁾

PART NUMBER	PACKAGE	BODY SIZE (NOM)
TPS62770	DSBGA (16)	1.58mm x 1.58mm

(1) For all available packages, see the orderable addendum at the end of the data sheet.

Typical Application Schematic

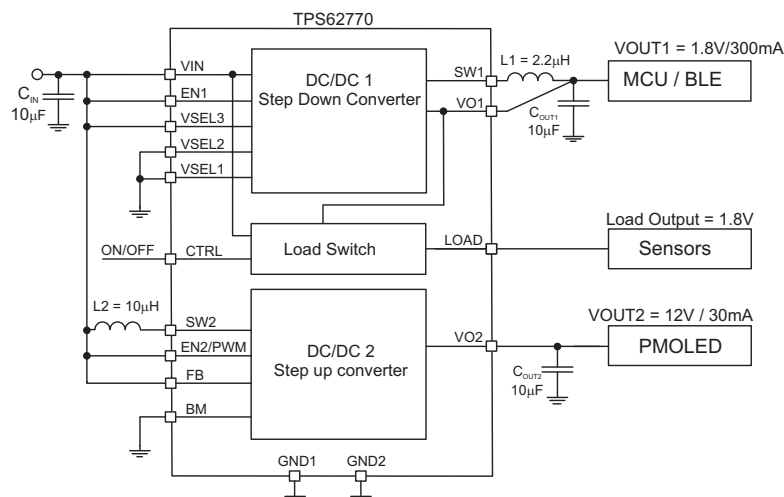

Copyright © 2016, Texas Instruments Incorporated



Table of Contents

1 Features	1	7.4 Device Functional Modes.....	13
2 Applications	1	8 Application and Implementation	17
3 Description	1	8.1 Application Information.....	17
4 Revision History	2	8.2 Typical Applications	18
5 Pin Configuration and Functions	3	9 Power Supply Recommendations	32
6 Specifications	4	10 Layout	32
6.1 Absolute Maximum Ratings	4	10.1 Layout Guidelines	32
6.2 ESD Ratings	4	10.2 Layout Example	33
6.3 Recommended Operating Conditions.....	5	11 Device and Documentation Support	34
6.4 Thermal Information	5	11.1 Device Support	34
6.5 Electrical Characteristics.....	5	11.2 Documentation Support	34
6.6 Typical Characteristics.....	8	11.3 Trademarks	34
7 Detailed Description	9	11.4 Electrostatic Discharge Caution.....	34
7.1 Overview	9	11.5 Glossary	34
7.2 Functional Block Diagram	9	12 Mechanical, Packaging, and Orderable	
7.3 Feature Description.....	10	Information	34

4 Revision History

Changes from Revision A (March 2016) to Revision B	Page
• Changed Application and Implementation section organization for clarity.....	17

Changes from Original (February 2016) to Revision A	Page
• Changed device status to Production Data and released the full data sheet.	1

5 Pin Configuration and Functions

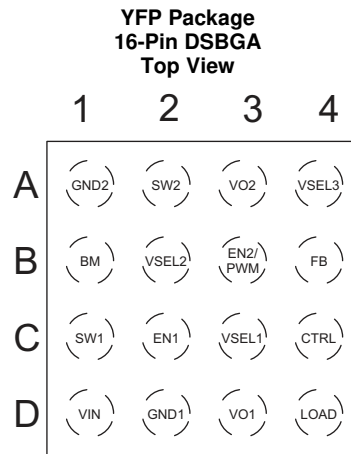
Table 1. Pin Functions

PIN		I/O	DESCRIPTION
NAME	NO		
EN2/PWM	B3	IN	Enable pin for the step-up converter. High level enables the devices, low level turns the device into shutdown mode. A PWM signal can be applied to this pin when used as a constant current driver (BM pin connected to VIN). The pin must be terminated.
GND2	A1	PWR	GND supply pin for the step-up converter. Connect this pin close to the GND terminals of the input and output capacitors.
SW2	A2	IN	The switch pin of the step-up converter. It is connected to the drain of the internal power MOSFET. Connect the inductor L2 between this pin and the input capacitor CIN
VO2	A3	OUT	Output of the step-up converter.
BM	B1	IN	This pin controls the operation mode of the step-up converter. With BM = high, the device features a low feedback voltage of 200mV, which can be scaled down by the integrated PWM to analog converter. With BM = low, the device operates with a 0.8V feedback voltage and operates as a step-up converter with voltage regulation. This pin must be terminated and set before the device is enabled.
FB	B4	IN	Feedback pin for the step-up converter to set the output voltage / current. Connect the pin to the center tap of a resistor divider to program the output voltage. When it is connected to the VIN pin, the output voltage is set to 12 V by an internal feedback divider network. When used as a LED current driver connect the sense resistor between this pin and GND. The LED string is connected between FB pin and VO2.
EN1	C2	IN	Enable pin for the step-down converter. High level enables the devices, low level turns the device into shutdown mode. The pin must be terminated.
VSEL1	C3	IN	Output voltage selection pins. See Table 2 for V _{OUT} selection. These pins must be terminated. The pins can be dynamically changed during operation.
VSEL2	B2	IN	
VSEL3	A4	IN	
CTRL	C4	IN	This pin controls the load switch between VO1 and LOAD. With CTRL = low, the LOAD switch is disabled. The pin must be terminated.
VIN	D1	PWR	VIN power supply pin. Connect the input capacitor close to this pin for best noise and voltage spike suppression. A ceramic capacitor of 10μF is required.
GND1	D2	PWR	GND supply pin for the step-down converter. Connect this pin close to both, the GND terminal of the input and output capacitor.
SW1	C1	OUT	This is the switch pin of the step-down converter and is connected to the internal MOSFET switches. Connect the inductor L1 between this terminal and the output capacitor.
VO1	D3	OUT	Output of the step-down converter. The output voltage is sensed via this pin to the internal feedback divider network for the regulation loop. In addition the internal load switch is connected between VO1 pin and LOAD pin. Connect this pin directly to the output capacitor with a short trace. The pin is connected to GND1 and discharges the output capacitor when the converter is disabled.
LOAD	D4	OUT	Output terminal of the internal load switch. With CTRL = high, the internal load switch connects VO1 to the LOAD pin. The switch features a slew rate control. This pin is pulled to GND with the CTRL = low. If not used, leave the pin open.

Table 2. Output Voltage Setting Step-Down Converter

VO1 [V]	VSEL3	VSEL2	VSEL1
1.0	0	0	0
1.05	0	0	1
1.1	0	1	0
1.2	0	1	1
1.8	1	0	0
1.9	1	0	1
2.0	1	1	0
3.0	1	1	1

6 Specifications

6.1 Absolute Maximum Ratings

 over operating free-air temperature range (unless otherwise noted) ⁽¹⁾

		MIN	MAX	UNIT
Pin voltage ⁽²⁾	VIN, FB	-0.3	6	V
	SW1	-0.3	V _{IN} +0.3V	V
	EN1, EN2/PWM, CTRL, BM, VSEL1-3	-0.3	V _{IN} +0.3V	V
	SW2, VO2	-0.3	32	V
	VO1, LOAD	-0.3	3.7	V
T _J	Operating junction temperature range	-40	125	°C
T _{stg}	Storage temperature range	-65	150	°C

- (1) Stresses beyond those listed under *absolute maximum ratings* may cause permanent damage to the device. These are stress ratings only and functional operation of the device at these or any other conditions beyond those indicated under *recommended operating conditions* is not implied. Exposure to absolute–maximum–rated conditions for extended periods may affect device reliability.
- (2) All voltage values are with respect to network ground terminal GND.

6.2 ESD Ratings

			VALUE	UNIT
V _(ESD)	Electrostatic discharge	Human body model (HBM), per ANSI/ESDA/JEDEC JS-001, all pins ⁽¹⁾	± 2000	V
		Charged device model (CDM), per JEDEC specification JESD22-C101, all pins ⁽²⁾	±500	

- (1) JEDEC document JEP155 states that 500-V HBM allows safe manufacturing with a standard ESD control process. The human body model is a 100-pF capacitor discharged through a 1.5-kΩ resistor into each pin.
- (2) JEDEC document JEP157 states that 250-V CDM allows safe manufacturing with a standard ESD control process.

6.3 Recommended Operating Conditions

		MIN	NOM	MAX	UNIT
V _{IN}	Input voltage range at VIN pin	2.5		5.5	V
I _{OUT1}	DC/DC 1 Step down converter output current L1 = 2.2μH, C _{OUT1} = 10 μF			300	mA
I _{OUT2}	DC/DC 2 Step up converter output current	2.5V < V _{IN} < 5.5V, V _{OUT2} = 12V, C _{OUT2} = 10μF, L = 10μH		30	mA
		2.5V < V _{IN} < 5.5V, V _{OUT2} = 12V, C _{OUT2} = 2x 10μF, L = 10μH		100	
		3V < V _{IN} < 5.5V, V _{OUT2} = 5V, C _{OUT2} = 2x 10μF, L = 4.7μH		200	
I _{LOAD}	Load current (current from LOAD pin)			100	
T _J	Operating junction temperature range	-40		125	°C
T _A	Ambient temperature range	-40		85	

6.4 Thermal Information

THERMAL METRIC ⁽¹⁾		TPS62770		UNIT
		YFP		
		TERMINALS		
R _{θJA}	Junction-to-ambient thermal resistance	90.6		°C/W
R _{θJctop}	Junction-to-case (top) thermal resistance	0.6		
R _{θJB}	Junction-to-board thermal resistance	13.8		
ψ _{JT}	Junction-to-top characterization parameter	2.8		
ψ _{JB}	Junction-to-board characterization parameter	13.7		
R _{θJcbot}	Junction-to-case (bottom) thermal resistance	n/a		

(1) For more information about traditional and new thermal metrics, see the *Semiconductor and IC Package Thermal Metrics* application report, [SPRA953](#).

6.5 Electrical Characteristics

V_{IN} = 3.6V, T_A = -40°C to 85°C typical values are at T_A = 25°C (unless otherwise noted)

PARAMETER		TEST CONDITIONS	MIN	TYP	MAX	UNIT
SUPPLY						
I _{SD}	Shutdown current into V _{IN}	EN1 = EN2/PWM = GND, CTRL GND, BM = GND,		0.1	1850	nA
V _{TH_UVLO+}	Undervoltage lockout threshold	Rising V _{IN}		2.1	2.22	V
V _{TH_UVLO-}		Falling V _{IN}		1.9	2	
INPUTS EN1, EN2/PWM, BM, CTRL, VSEL 1-3						
V _{IH TH}	High level input threshold				1.2	V
V _{IL TH}	Low level input threshold		0.4			V
I _{IN}	Input bias Current	T _J = 25°C			10	nA
		T _J = -40°C to 85°C			25	

Electrical Characteristics (continued)
 $V_{IN} = 3.6V$, $T_A = -40^{\circ}C$ to $85^{\circ}C$ typical values are at $T_A = 25^{\circ}C$ (unless otherwise noted)

PARAMETER		TEST CONDITIONS	MIN	TYP	MAX	UNIT	
STEP-DOWN CONVERTER							
I_Q	Operating quiescent current	EN1 = V_{IN} , EN2/PWM = GND, CTRL = GND, $I_{OUT} = 0\mu A$, $V_{OUT} = 1.8V$, device not switching,		370	1850	nA	
		EN1 = V_{IN} , EN2/PWM = GND, $I_{OUT} = 0mA$, CTRL = GND, $V_{OUT} = 1.8V$, device switching		500			
V_{VOUT}	Output voltage range		1.0		3.0	V	
	Output voltage accuracy	PFM mode	-2.5	0	2.5	%	
		PWM mode	-2	0	2		
	DC output voltage load regulation	$V_{OUT} = 1.8V$		0.001		%/mA	
DC output voltage line regulation	$V_{OUT} = 1.8V$, $I_{OUT} = 10mA$, $2.5V \leq V_{IN} \leq 5.5V$		0		%/V		
$R_{DS(ON)}$	High side MOSFET on-resistance	$I_{OUT} = 50mA$		0.45		Ω	
	Low Side MOSFET on-resistance			0.22			
I_{LIMF}	High side MOSFET switch current limit		480	600	720	mA	
	Low side MOSFET switch current limit			600		mA	
R_{DSCH_VO1}	Discharge switch on-resistance	EN = GND, $I_{VO1} = -10mA$ into VO1 pin		20	65	Ω	
I_{IN_VO1}	Bias current into VO1 pin	EN = V_{IN} , $V_{OUT} = 1.8V$	$T_J = 25^{\circ}C$	40	100	nA	
			$T_J = -40^{\circ}C$ to $85^{\circ}C$		1010		
V_{TH_100+}	Auto 100% Mode leave detection threshold ⁽¹⁾	Rising V_{IN} , 100% Mode is left with $V_{IN} = V_{OUT} + V_{TH_100+}$, max value at $T_J = 85^{\circ}C$	150	250	370	mV	
V_{TH_100-}	Auto 100% Mode enter detection threshold ⁽¹⁾	Falling V_{IN} , 100% Mode is entered with $V_{IN} = V_{OUT} + V_{TH_100-}$, max value at $T_J = 85^{\circ}C$	85	200	310		
t_{ONmin}	Minimum ON time	$V_{OUT} = 2.0V$, $I_{OUT} = 0mA$		225		ns	
t_{OFFmin}	Minimum OFF time			50		ns	
$t_{Startup_delay}$	Regulator start up delay time	From transition EN1 = low to high until device starts switching		1	5	ms	
$t_{Softstart}$	Softstart time with reduced switch current limit			700	1200	μs	
$I_{LIM_softstart}$	High side MOSFET switch current limit	Reduced switch current limit during softstart		80	150	200	mA
	Low side MOSFET switch current limit			150			
LOAD SWITCH							
R_{LOAD}	MOSFET on-resistance	$I_{LOAD} = 50mA$, CTRL = V_{IN} , $V_{OUT} = 1.8V$,		0.6	1.27	Ω	
t_{rise_LOAD}	V_{LOAD} rise time	Starting with CTRL low to high transition, time to ramp V_{LOAD} from 95%, $V_{OUT} = 1.8V$, $I_{LOAD} = 20mA$		315	800	μs	
R_{DCHRG}	MOSFET on-resistance			20	65	Ω	

(1) V_{IN} is compared to the programmed output voltage (V_{OUT}). When $V_{IN} - V_{OUT}$ falls below V_{TH_100-} the device enters 100% Mode by turning the high side MOSFET on. The 100% Mode is exited when $V_{IN} - V_{OUT}$ exceeds V_{TH_100+} and the device starts switching. The hysteresis for the 100% Mode detection threshold $V_{TH_100+} - V_{TH_100-}$ will always be positive and will be approximately 50 mV(typ.)

Electrical Characteristics (continued)

 $V_{IN} = 3.6V$, $T_A = -40^{\circ}C$ to $85^{\circ}C$ typical values are at $T_A = 25^{\circ}C$ (unless otherwise noted)

PARAMETER		TEST CONDITIONS	MIN	TYP	MAX	UNIT
STEP-UP CONVERTER						
I_{Q_VIN}	Quiescent current into VIN pin	EN2/PWM = VIN, BM = GND, EN1 = GND, no load, no switching, $V_{OUT} = 12V$		110	200	μA
V_{OUT}	Output voltage range	EN2/PWM = VIN, BM = GND	4.5		15	V
V_{OUT_12V}	12-V output voltage accuracy	FB pin connected to VIN pin, EN2/PWM = V_{IN} , BM = GND	11.7	12	12.3	V
V_{FB}	Feedback voltage	PWM mode, BM = GND, EN2/PWM = V_{IN}	0.775	0.795	0.814	V
		PFM mode, BM = GND, EN2/PWM = V_{IN}		0.803		V
	Feedback regulation voltage under brightness control	EN2/PWM = VIN, BM = VIN,	189	200	206	mV
		VFB = 50mV, BM = VIN, D(PWM) @ EN2/PWM = 25%, VFB = 20mV, BM = VIN, D(PWM) @ EN2/PWM = 10%	40	50	60	mV
t_{Dim_Off}	Dimming signal on pin EN2/PWM			270	160	μs
t_{Dim_On}			1			μs
V_{OVP}	Output overvoltage protection threshold		17	17.7	18.4	V
V_{OVP_HYS}	Over voltage protection hysteresis			800		mV
I_{FB_LKG}	Leakage current into FB pin			5	200	nA
I_{SW_LKG}	Leakage current into SW pin	EN2/PWM = GND		5	500	nA
$R_{DS(on)}$	Isolation MOSFET on resistance	$V_{OUT} = 12V$		850		m Ω
	Low-side MOSFET on resistance	$V_{OUT} = 12V$		450		m Ω
f_{SW}	Switching frequency	$V_{OUT} = 12V$, PWM mode	850	1050	1250	kHz
t_{ON_min}	Minimal switch on time			150	250	ns
I_{LIM_SW}	Peak switch current limit	$V_{OUT} = 12V$	730	970	1230	mA
I_{LIM_CHG}	Pre-charge current	$V_{OUT} = 0V$		30	55	mA
$t_{Softstart}$	Pre-charge time	BM = GND, EN2/PWM from low to high until device starts switching, $I_{OUT2} = 0mA$, $C_{OUT2} = 10\mu F$		6		ms
	Startup time	V_{OUT} from V_{IN} to 12 V, $C_{OUT_effective} = 2.2\mu F$, $I_{OUT} = 0A$		6		ms

6.6 Typical Characteristics

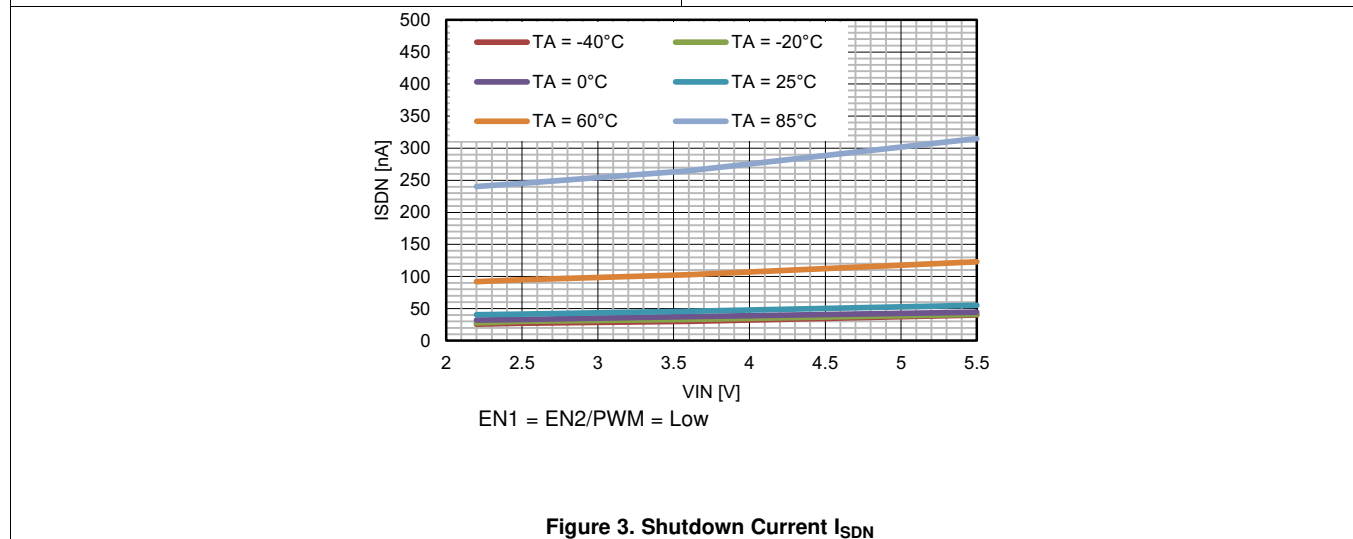
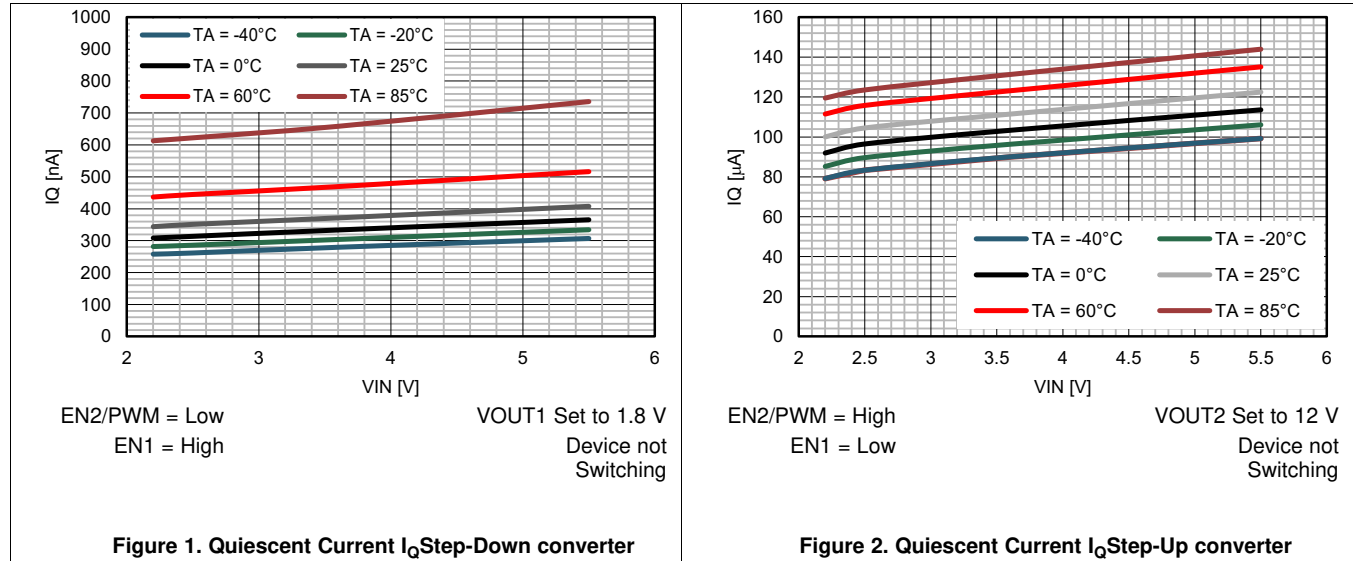

7 Detailed Description

7.1 Overview

The TPS62770 is a tiny power solution for wearable applications including a 370nA ultra low Iq step-down converter, a slew rate controlled load switch and a dual mode step-up converter. The output voltage of the step-down converter can be selected with three VSEL pins between 1.0 V, 1.05 V, 1.1 V, 1.2 V, 1.8 V, 1.9 V, 2.0 V and 3.0 V.

The dual mode step-up converter can generate a constant output voltage up to 15 V, such as PMOLED supply or, a constant output current, such as LED back light supply.

7.2 Functional Block Diagram

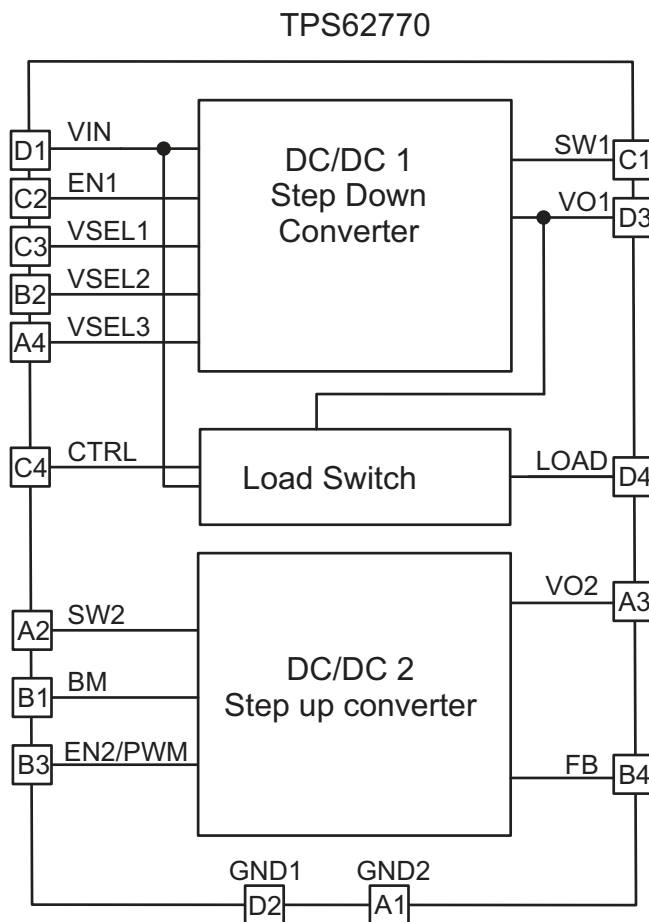

Copyright © 2016, Texas Instruments Incorporated

7.3 Feature Description

7.3.1 Step-Down Converter Device

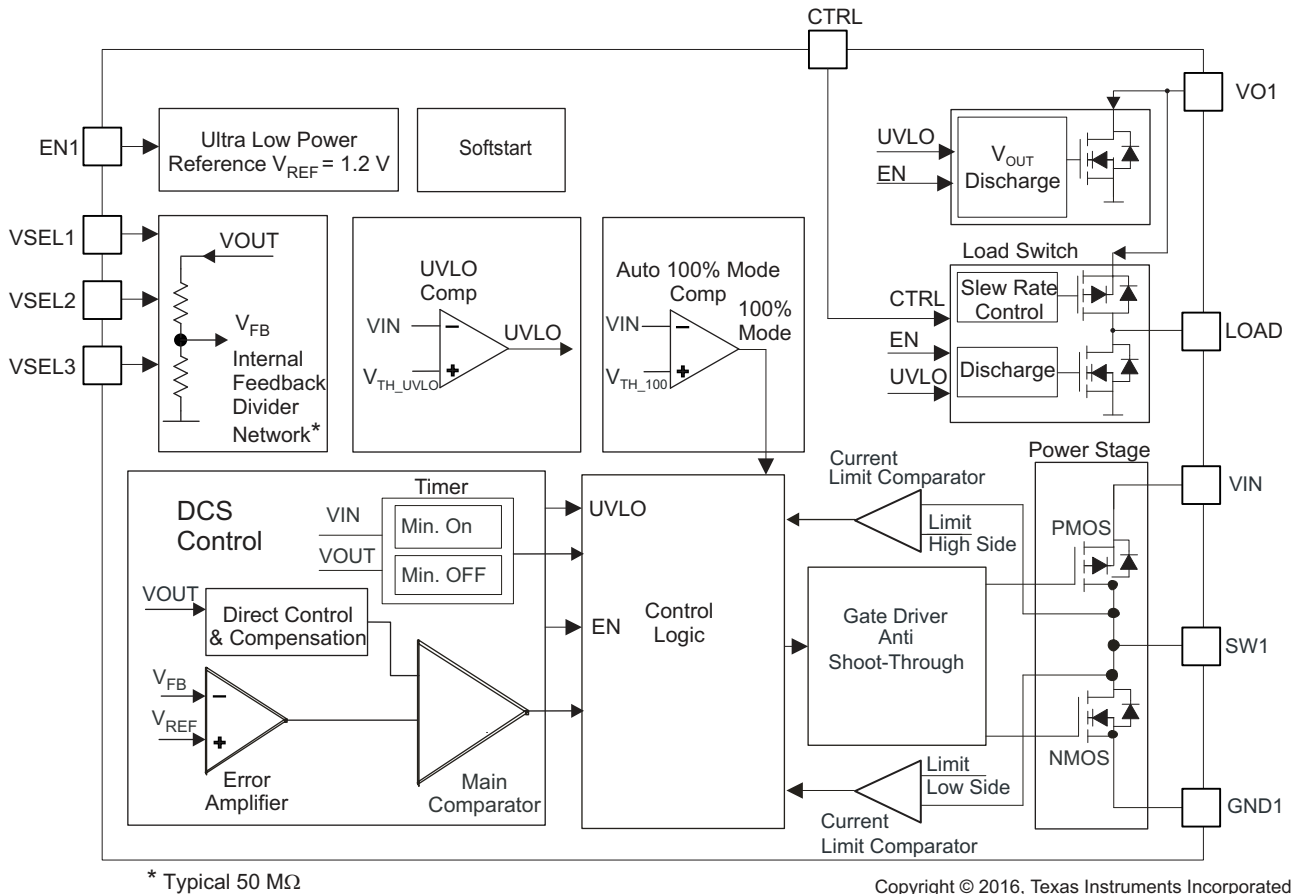

Figure 4. Block Diagram Step-Down Converter with Load Switch

7.3.1.1 DCS-Control™

TI's DCS-Control™ (Direct Control with Seamless Transition into Power Save Mode) is an advanced regulation topology, which combines the advantages of hysteretic and voltage mode control. Characteristics of DCS-Control™ are excellent AC load regulation and transient response, low output ripple voltage and a seamless transition between PFM and PWM mode operation. DCS-Control™ includes an AC loop which senses the output voltage (VO1 pin) and directly feeds the information to a fast comparator stage. This comparator sets the switching frequency, which is constant for steady state operating conditions, and provides immediate response to dynamic load changes. In order to achieve accurate DC load regulation, a voltage feedback loop is used. The internally compensated regulation network achieves fast and stable operation with small external components and low ESR capacitors. The DCS-Control™ topology supports PWM (Pulse Width Modulation) mode for medium and high load conditions and a Power Save Mode at light loads. Since DCS-Control™ supports both operation modes within one single building block, the transition from PWM to Power Save Mode is seamless with minimum output voltage ripple. The step-down converter offers both excellent DC voltage and superior load transient regulation, combined with low output voltage ripple, minimizing interference with RF circuits.

7.3.1.2 Output Voltage Selection with pins VSEL1-VSEL3

The step-down converter doesn't require an external resistor divider network to program the output voltage. The device integrates a high impedance feedback resistor divider network that is programmed by the pins VSEL1-3. It supports an output voltage range from 1.0 V to 3.0 V. The output voltage is programmed according to [Table 2](#). The output voltage can be changed during operation. This can be used for simple dynamic output voltage scaling.

Feature Description (continued)

7.3.1.3 CTRL / Output Load

With the CTRL pin set to high, the integrated loadswitch is activated and connects the LOAD pin to the VO1 pin to power up an additional sub-system. The load switch is slew rate controlled to support soft switching and not to impact the regulated output VO1. If CTRL pin is pulled to GND, the LOAD pin is disconnected from the VO1 pin and internally connected to GND by an internal discharge switch. The CTRL pin can be controlled by a micro controller.

7.3.1.4 Output Discharge At Pins VO1 And LOAD

Both the VO1 pin and the LOAD pin feature a discharge circuit to connect each rail to GND, once they are disabled. This feature prevents residual charge voltages on capacitors connected to these pins, which may impact proper power up of the main- and sub-system. With CTRL pin pulled to low, the discharge circuit at the LOAD pin becomes active. With the EN pin pulled to low, the discharge circuits at both pins VO1 and Load are active. The discharge circuits of both rails VO1 and LOAD are associated with the UVLO comparator as well. Both discharge circuits become active once the input voltage VIN has dropped below the UVLO comparator threshold VTH_UVLO- and the UVLO comparator triggers.

7.3.1.5 Undervoltage Lockout UVLO

The UVLO circuit shuts down the device if the input voltage V_{IN} drops to typical 1.9 V. The device starts up at an input voltage of typically 2.1 V.

7.3.1.6 Short Circuit Protection

The step-down converter integrates a current limit on the high side, as well on the low side MOSFETs to protect the device against overload or short circuit conditions. The peak current in the switches is monitored cycle by cycle. If the high side MOSFET current limit is reached, the high side MOSFET is turned off and the low side MOSFET is turned on until the switch current decreases below the low side MOSFET current limit. Once the low side MOSFET current limit trips, the low side MOSFET is turned off and the high side MOSFET turns on again.

Feature Description (continued)

7.3.2 Step-Up Converter Device

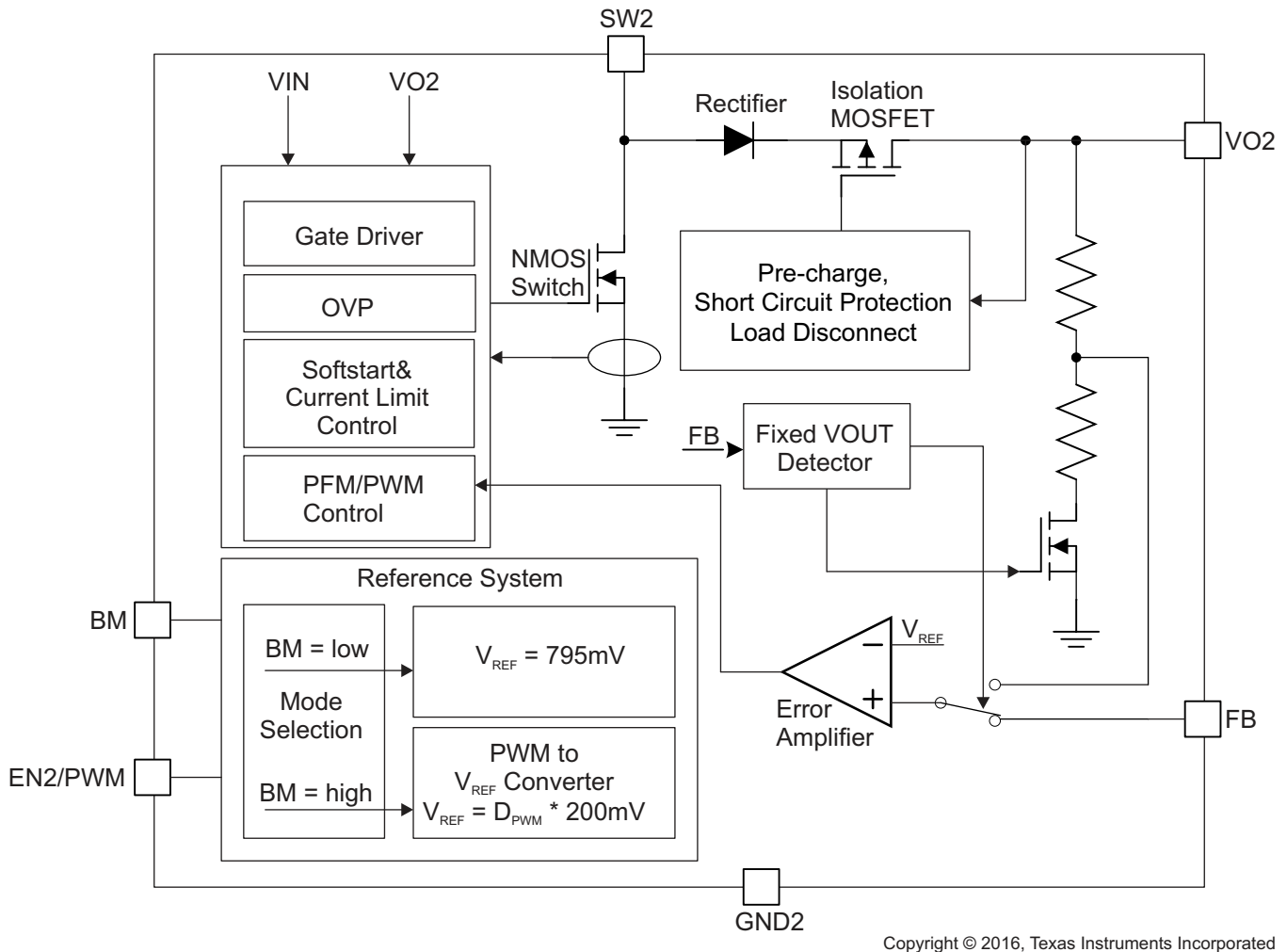

Figure 5. Block Diagram Step-Up Converter

The step-up converter is designed for applications requiring voltages up to 15 V from an Li-Ion battery and tiny solution size such as PMOLED displays or LED back light for small size LCD displays. The step-up converter operates in two different modes, either as constant output voltage step-up converter operating with 0.8 V internal reference or as a constant output current step-up converter operating with a reduced internal reference voltage of 200mV. The block integrates power switch, input/output isolation switch, and power diode.

7.3.2.1 Under-Voltage Lockout

See section [Undervoltage Lockout UVLO](#) description for the Step-Down Converter.

7.3.2.2 Output Disconnect

One common issue with conventional step-up regulators is the conduction path from input to output even when the device is disabled. It creates three problems, which are inrush current during start-up, output leakage current during shutdown and excessive over load current. The step-up converter has an integrated isolation (load disconnect) switch, which is turned off under shutdown mode and over load conditions, thereby opening the current path to the output VO2. Thus the device can truly disconnect the load from the input voltage and minimize the leakage current during shutdown mode.

Feature Description (continued)

7.3.2.3 12 V Fixed Output Voltage

The step-up converter features an internal default 12-V output voltage setting by connecting the FB pin to the VIN pin. Therefore no external resistor divider network is required minimizing the total solution size.

7.3.2.4 Mode Selection With Pin BM

The step-up converter can operate in two different modes. With pin BM = low the device regulates to a constant output voltage; with BM = high, the device can regulate a constant output current. Further details are in section [Constant-Current Step-Up Mode Operation](#) and section [Constant-Voltage Step-Up Mode Operation](#). The operation mode needs to be selected before the device is enabled. Pin BM may not be changed during operation.

7.3.2.5 Output Overvoltage Protection

When the output voltage exceeds the OVP threshold of 17.7 V, the device stops switching. Once the output voltage falls 0.8 V below the OVP threshold, the device resumes operation again.

7.3.2.6 Output Short Circuit Protection

The step-up converter starts to limit the output current whenever the output voltage drops below 4 V. When the VOUT pin is shorted to ground, the output current is limited. This function protects the device from being damaged when the output is shorted to ground.

7.3.2.7 PWM to Analog Converter AT PIN EN2/PWM

In constant current step-up mode operation two control functions are associated with the pin EN2/PWM:

- a) Enable/ disable of the step-up converter
- b) PWM to analog conversion to scale the internal reference voltage.

The internal reference voltage scales proportional with the duty cycle of the PWM signal applied at the pin EN2/PWM. More details in section [Constant-Current Step-Up Mode Operation](#).

7.4 Device Functional Modes

7.4.1 Step-Down Converter

7.4.1.1 Enable and Shutdown

The step-down converter is turned on with EN1 = high. With EN1 = low the step-down converter is turned off. This pin must be terminated.

7.4.1.2 Power Save Mode Operation

At light loads, the device operates in Power Save Mode. The switching frequency varies linearly with the load current. In Power Save Mode the device operates in PFM (Pulse Frequency Modulation) that generates a single switching pulse to ramp up the inductor current and recharges the output capacitor, followed by a sleep period where most of the internal circuits are shutdown to achieve lowest operating quiescent current. During this time, the load current is supported by the output capacitor. The duration of the sleep period depends on the load current and the inductor peak current. During the sleep periods, the current consumption is reduced to 360 nA. This low quiescent current consumption is achieved by an ultra low power voltage reference, an integrated high impedance feedback divider network and an optimized Power Save Mode operation.

7.4.1.3 PWM Mode Operation

At moderate to heavy load currents, the device operates in PWM mode with continuous conduction. The switching frequency is up to 1.6 MHz with a controlled frequency variation depending on the input voltage and load current. If the load current decreases, the converter seamlessly enters Power Save Mode to maintain high efficiency down to very light loads.

Device Functional Modes (continued)

7.4.1.4 Device Start-up and Soft Start

The step-down converter has an internal soft start to minimize inrush current and input voltage drop during start-up. Once the device is enabled the device starts switching after a typical delay time of 1 ms. Then the soft start time of typical 700 μ s begins with a reduced current limit of typical 150mA. When this time expires the device enters full current limit operation.

7.4.1.5 Automatic Transition Into 100% Mode

Once the input voltage comes close to the output voltage, the DC/DC converter stops switching and enters 100% duty cycle operation. It connects the output V_{OUT} via the inductor and the internal high side MOSFET switch to the input V_{IN} , once the input voltage V_{IN} falls below the 100% mode enter threshold, V_{TH_100-} . The DC/DC regulator is turned off, switching stops and therefore no output voltage ripple is generated. Because the output is connected to the input, the output voltage follows the input voltage minus the voltage drop across the internal high side switch and the inductor. Once the input voltage increases and trips the 100% mode exit threshold, V_{TH_100+} , the DC/DC regulator turns on and starts switching again.

7.4.2 Step-Up Converter

7.4.2.1 Enable and Shutdown

The device is turned on with EN2/PWM = high. With EN2/PWM = low the device enters shutdown mode. In constant current step-up mode (BM = high) the pin EN2/PWM has to be pulled to low level for longer than $t_{Dim_Off\ max}$ to enter shutdown mode. This pin must be terminated.

7.4.2.2 Soft Start

The step-up converter begins soft start when the EN2/PWM pin is pulled high. At the beginning of the soft start period, the isolation FET is turned on slowly to charge the output capacitor with 30-mA current for about 6 ms. This is called the pre-charge phase. The output is charged up to the level of the input voltage V_{IN} . After the pre-charge phase, the device starts switching and the output voltage ramps up. This is called switching soft start phase. An internal soft start circuit limits the peak inductor current.

7.4.2.3 Power Save Mode

The step-up converter integrates a power save mode with pulse frequency modulation (PFM) to improve efficiency at light load. When the load current decreases, the inductor peak current set by the output of the error amplifier declines to regulate the output voltage. When the inductor peak current hits the low limit of 240 mA, the output voltage will exceed the set voltage as the load current decreases further. The device enters power save mode once the FB voltage exceeds the PFM mode threshold, which is 1% above the nominal output voltage. It stops switching, the load is supplied by the output capacitor and the output voltage begins to decline. When the FB voltage falls below the PFM mode threshold voltage, the device starts switching again to ramp up the output voltage.

Device Functional Modes (continued)

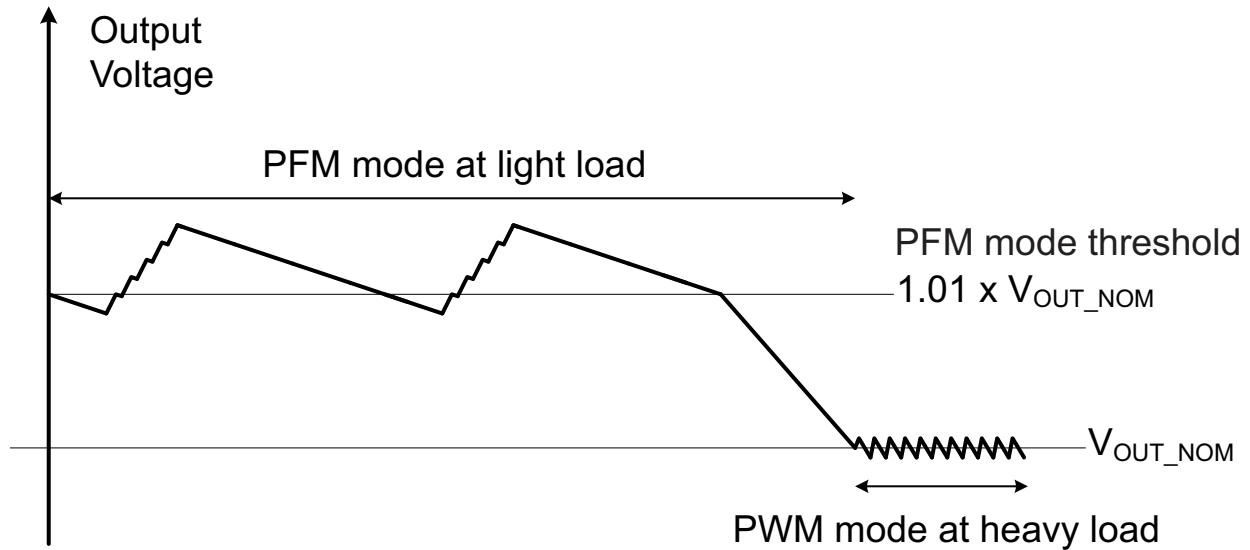

Figure 6. Output Voltage in PFM and PWM Mode

7.4.2.4 PWM Mode

The step-up converter uses a quasi-constant 1.0-MHz frequency pulse width modulation (PWM) at moderate to heavy load current. Based on the input voltage to output voltage ratio, a circuit predicts the required off-time. At the beginning of the switching cycle, the NMOS switching FET is turned on. The input voltage is applied across the inductor and the inductor current ramps up. In this phase, the output capacitor is discharged by the load current. When the inductor current hits the current threshold that is set by the output of the error amplifier, the PWM switch is turned off, and the power diode is forward-biased. The inductor transfers its stored energy to charge the output capacitor and supply the load. When the off-time is expired, the next switching cycle starts again. The error amplifier compares the FB pin voltage with an internal reference voltage, and its output determines the inductor peak current.

7.4.2.5 Constant-Current Step-Up Mode Operation

With pin BM = high the converter can regulate to a constant output current. The internal reference voltage is therefore reduced to 200mV. In order to regulate a constant output current, a sense resistor has to be connected between pin FB and GND, see Figure 7. The device features in this operation mode a PWM to analog converter at pin EN2/PWM. The internal reference voltage is scaled according to the duty cycle of the PWM signal applied to pin EN2/PWM, see Figure 8. When the pin EN2/PWM is pulled low longer than $t_{Dim_OFF\ max}$, the step-up converter enters shutdown mode. The constant output current I_{OUT2} can be calculated according equations Equation 1 and Equation 2.

Device Functional Modes (continued)

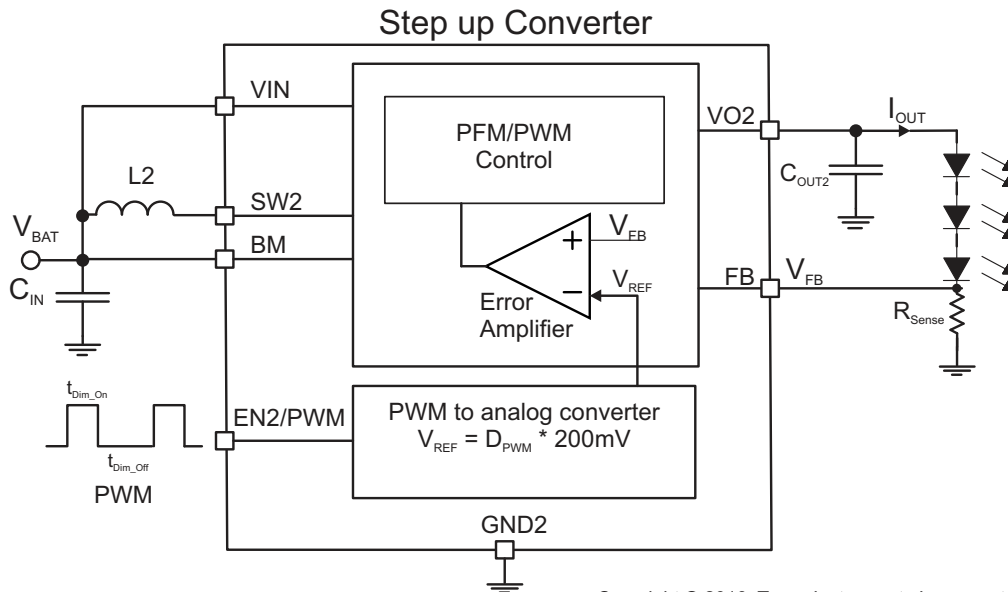

Figure 7. Step-Up Converter in Constant-Current Operation Mode

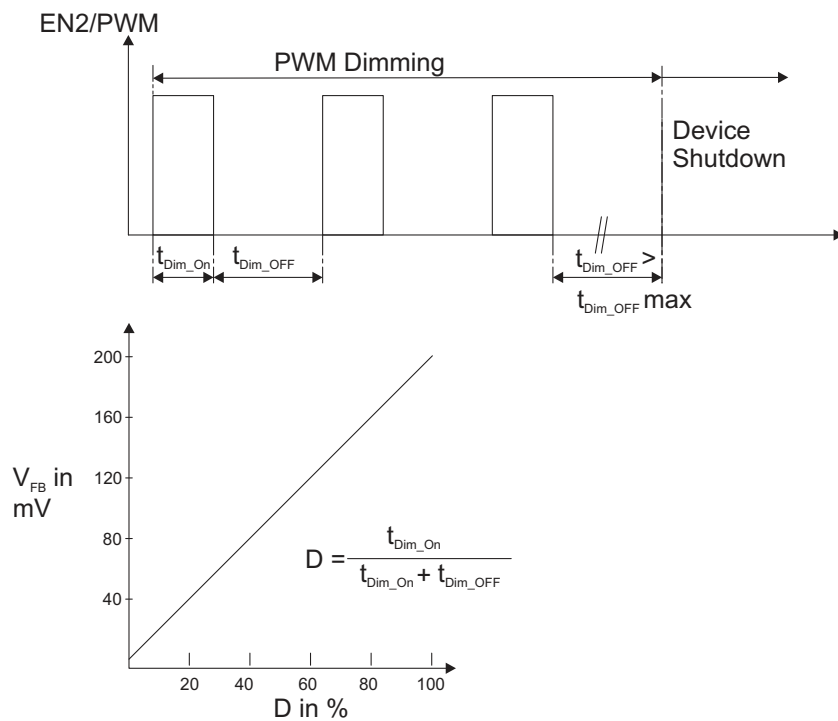

Figure 8. EN2/PWM Pin Function

$$I_{OUT2} = \frac{V_{FB}}{R_{Sense}} \tag{1}$$

$$I_{OUT2} = D_{PWM} \times \frac{200 \text{ mV}}{R_{Sense}} \tag{2}$$

Device Functional Modes (continued)

7.4.2.6 Constant-Voltage Step-Up Mode Operation

With pin BM = low the converter operates as a constant output voltage step-up converter. The internal reference voltage is set to 795 mV. A feedback resistor divider need to be connected between VOUT, FB and GND with its tap point connected to FB pin. The device provides a fixed set 12 V output voltage if the FB pin is connected to VIN. In this case no external resistor divider network is needed.

8 Application and Implementation

NOTE

Information in the following applications sections is not part of the TI component specification, and TI does not warrant its accuracy or completeness. TI's customers are responsible for determining suitability of components for their purposes. Customers should validate and test their design implementation to confirm system functionality.

8.1 Application Information

The TPS62770 is a tiny power solution for wearable applications including a 370 nA ultra low Iq step-down converter, a slew-rate controlled load switch and a dual-mode step-up converter. The output voltage of the step-down converter can be selected between 1.0 V and 3.0 V. The output voltage can be changed during operation. In shutdown mode, the output of the step-down converter is pulled to GND. The integrated load switch is internally connected to the output of the step-down converter and features slew rate control during turn on phase. Once turned off, its output is connected to GND. In order to achieve better supply voltage decoupling / noise reduction a capacitor can be connected on the LOAD output. The $R_{\text{DS(on)}}$ of the load switch and the connected capacitor form a RC filter.

The dual mode step-up converter can generate a constant output voltage up to 15V, e.g. for PMOLED supply, or a constant output current, e.g. for LED back light supply. The output voltage can be adjusted up to 15 V with external resistors, or set to fixed 12 V by connecting the FB pin to VIN. The device features an internal over voltage protection of 17 V in case the FB node is left open or tight to GND. It includes an internal rectifier and load disconnect function. When used as constant output current driver, the device offers a PWM to analog converter to scale down the reference voltage according to the duty cycle of the PWM signal.

The design guideline provides a component selection to operate the device within the recommended operating conditions.

8.2 Typical Applications

8.2.1 TPS62770 Step-Down Converter + Load Switch

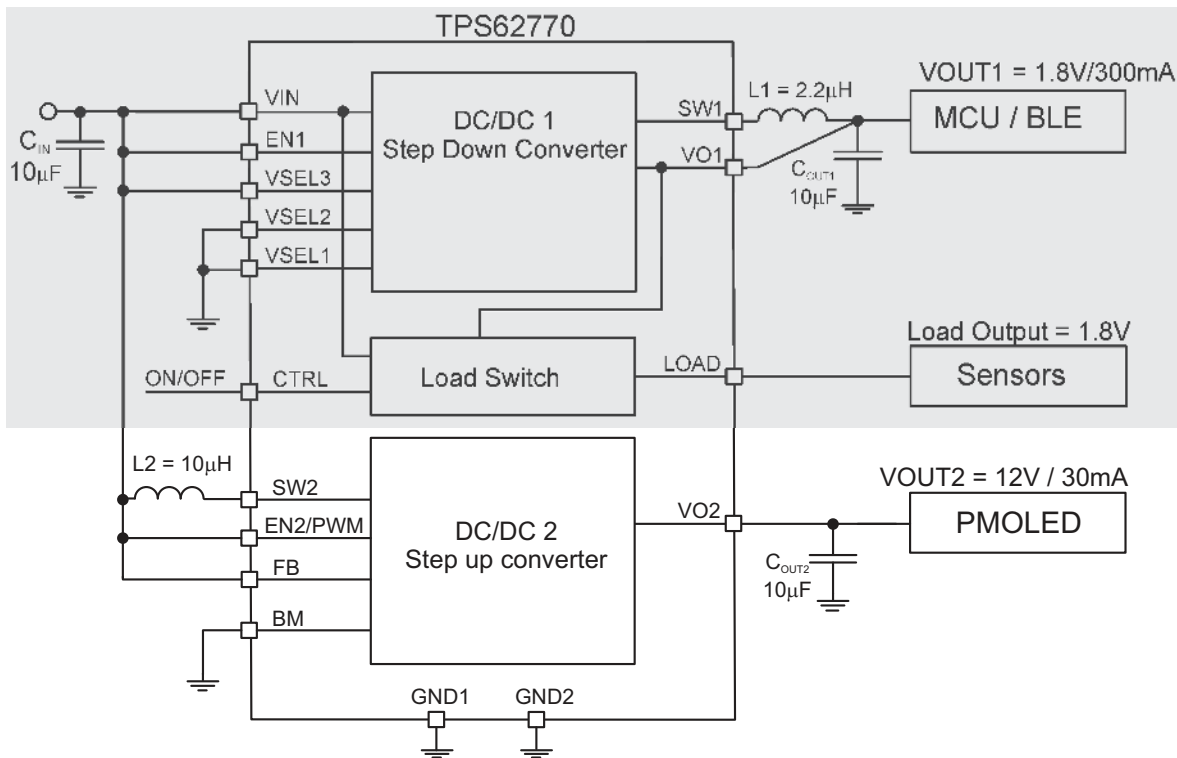

Copyright © 2016, Texas Instruments Incorporated

Figure 9. Simplified Schematic – TPS62770 Step-Down Converter Set to 1.8-V Output

8.2.1.1 Design Requirements

The LC output filter should meet the values shown in Table 3.

Table 3. Recommended LC Output Filter Combinations for the Step-Down Converter

INDUCTOR VALUE [µH] ⁽¹⁾	OUTPUT CAPACITOR VALUE [µF] ⁽²⁾	
	10 µF	22 µF
2.2	√ ⁽³⁾	√

- (1) Inductor tolerance and current de-rating is anticipated. The effective inductance can vary by 20% and -30%.
- (2) Capacitance tolerance and bias voltage de-rating is anticipated. The effective capacitance can vary by 20% and -50%.
- (3) This LC combination is the standard value and recommended for most applications.

8.2.1.2 Detailed Design Procedure

8.2.1.2.1 Setting The Output Voltage Of The Step-Down Converter

The output voltage is set with the VSEL1-3 pins according to Table 2. No further external components are required.

8.2.1.2.2 Inductor Selection Step-Down Converter

The inductor value affects its peak-to-peak ripple current, the PWM-to-PFM transition point, the output voltage ripple and the efficiency. The selected inductor has to be rated for its DC resistance and saturation current. The inductor ripple current (ΔI_L) decreases with higher inductance and increases with higher V_{IN} or V_{OUT} and can be estimated according to Equation 3.

Equation 4 calculates the maximum inductor current under static load conditions. The saturation current of the inductor should be rated higher than the maximum inductor current, as calculated with **Equation 4**. This is recommended because during a heavy load transient the inductor current rises above the calculated value. A more conservative way is to select the inductor saturation current above the high-side MOSFET switch current limit, I_{LIMF} .

$$\Delta I_L = V_{out} \times \frac{1 - \frac{V_{out}}{V_{in}}}{L \times f} \quad (3)$$

$$I_{Lmax} = I_{outmax} + \frac{\Delta I_L}{2} \quad (4)$$

With:

f = Switching Frequency

L = Inductor Value

ΔI_L = Peak to Peak inductor ripple current

I_{Lmax} = Maximum Inductor current

In DC/DC converter applications, the efficiency is essentially affected by the inductor AC resistance (i.e. quality factor) and by the inductor DCR value. Increasing the inductor value produces lower RMS currents, but degrades transient response. For a given physical inductor size, increased inductance usually results in an inductor with lower saturation current.

The total losses of the coil consist of both the losses in the DC resistance (R_{DC}) and the following frequency-dependent components:

- The losses in the core material (magnetic hysteresis loss, especially at high switching frequencies)
- Additional losses in the conductor from the skin effect (current displacement at high frequencies)
- Magnetic field losses of the neighboring windings (proximity effect)
- Radiation losses

8.2.1.2.3 Input and Output Capacitor Selection

Ceramic capacitors with low ESR values have the lowest output voltage ripple and are recommended. The output capacitor requires either an X7R or X5R dielectric. Y5V and Z5U dielectric capacitors, aside from their wide variation in capacitance over temperature, become resistive at high frequencies. At light load currents, the converter operates in Power Save Mode and the output voltage ripple is dependent on the output capacitor value and the PFM peak inductor current. A 10 μ F ceramic capacitor is recommended as input capacitor.

Table 4 shows a list of tested input/output capacitors.

Table 4. Components for *Application Curves – TPS62770 Step-Down Converter + Load Switch*

REFERENCE	DESCRIPTION	VALUE	PACKAGE CODE / SIZE [mm x mm x mm]	MANUFACTURER ⁽¹⁾
CIN	Ceramic capacitor X5R 6.3V, GRM155R60J106ME11	10 μ F	0402 / 1.0 x 0.5 x 0.5	Murata
COUT1	Ceramic capacitor X5R 6.3V, GRM155R60J106ME11	10 μ F	0402 / 1.0 x 0.5 x 0.5	Murata
L1	Inductor DFE201610C	2.2 μ H	2.0 x 1.6 x 1.0	Toko

(1) See [Third-party Products Disclaimer](#)

8.2.1.3 Application Curves – TPS62770 Step-Down Converter + Load Switch

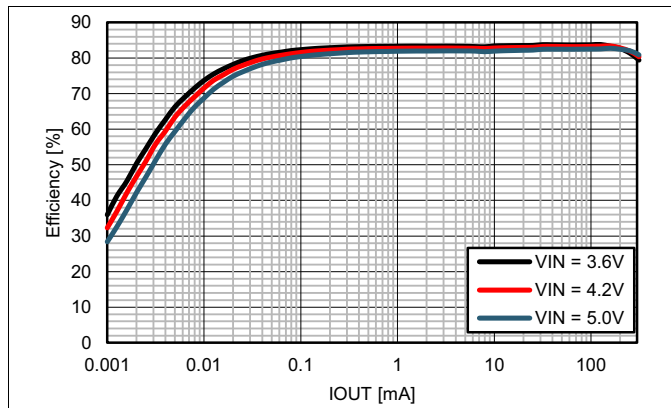

Figure 10. Efficiency vs. IOU1, VOUT1 = 1.0 V

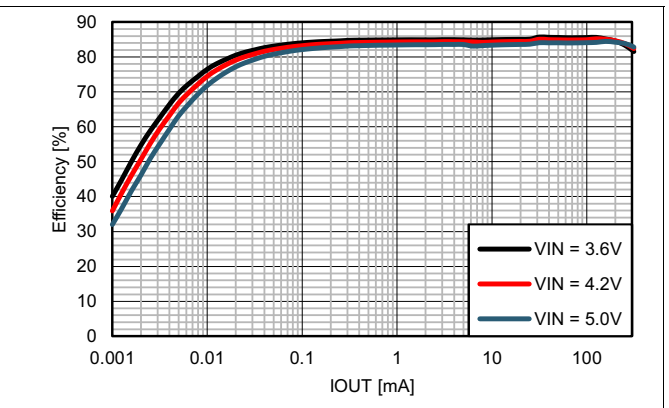

Figure 11. Efficiency vs. IOU1, VOUT1 = 1.2 V

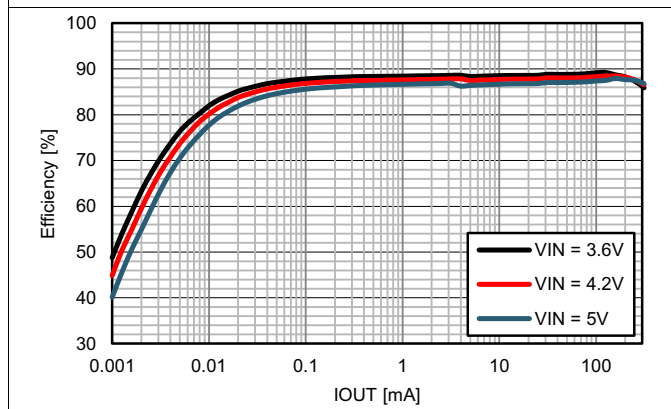

Figure 12. Efficiency vs. IOU1, VOUT1 = 1.8 V

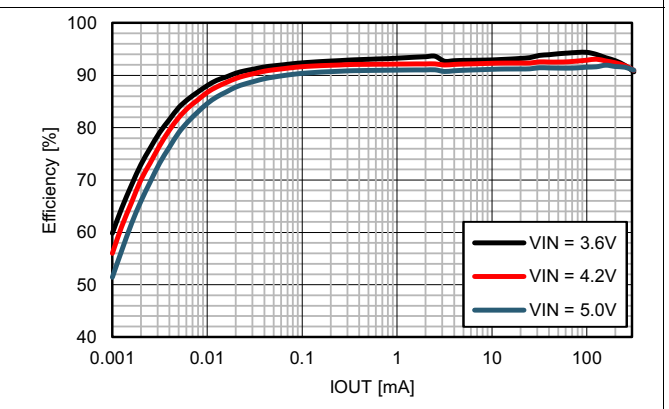

Figure 13. Efficiency vs. IOU1, VOUT1 = 3.0 V

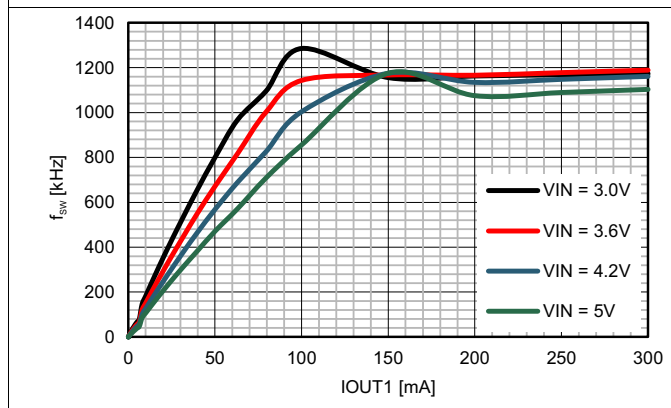

Figure 14. F_{sw} vs. IOU1, VOUT1 = 1.1 V

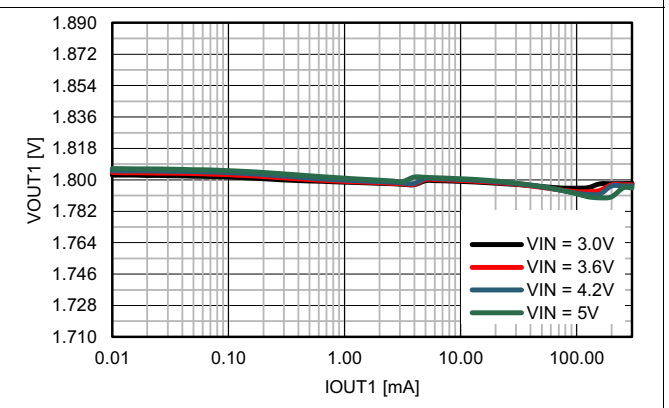
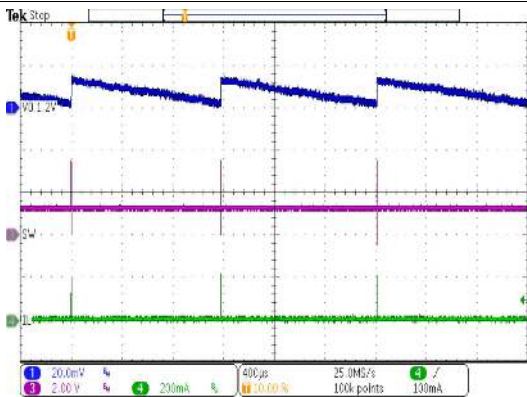
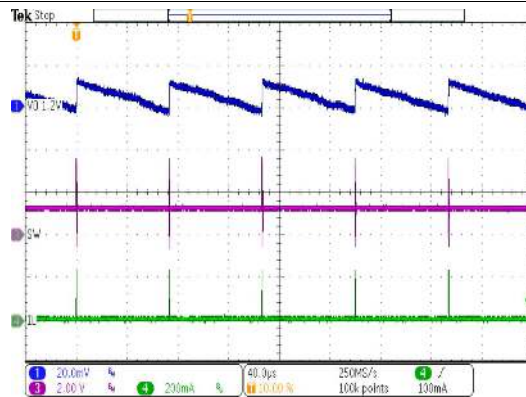

Figure 15. VOUT1 = 1.8 V vs IOU1



$V_{IN} = 3.6\text{ V}$
 $V_{OUT} = 1.2\text{ V}$
 $I_{OUT} = 50\ \mu\text{A}$

Figure 16. Typical Operation in Power Save Mode



$V_{IN} = 3.6\text{ V}$
 $V_{OUT} = 1.2\text{ V}$
 $I_{OUT} = 1\text{ mA}$

Figure 17. Typical Operation in Power Save Mode

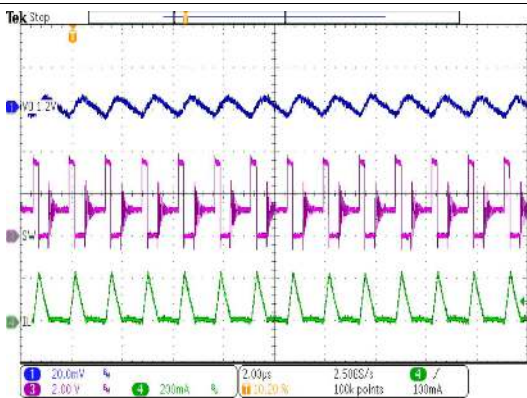

$V_{IN} = 3.6\text{ V}$
 $V_{OUT} = 1.2\text{ V}$
 $I_{OUT} = 50\text{ mA}$

Figure 18. Typical Operation in Power Save Mode

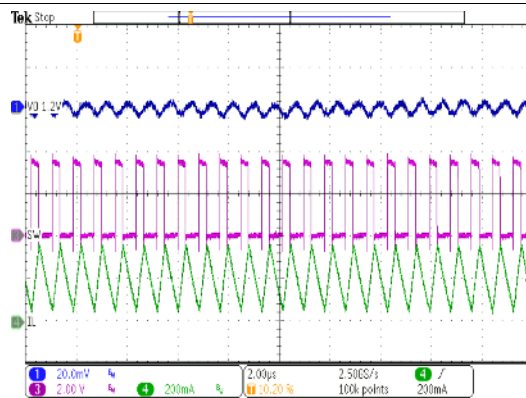

$V_{IN} = 3.6\text{ V}$
 $V_{OUT} = 1.2\text{ V}$
 $I_{OUT} = 200\text{ mA}$

Figure 19. Typical Operation in PWM Mode

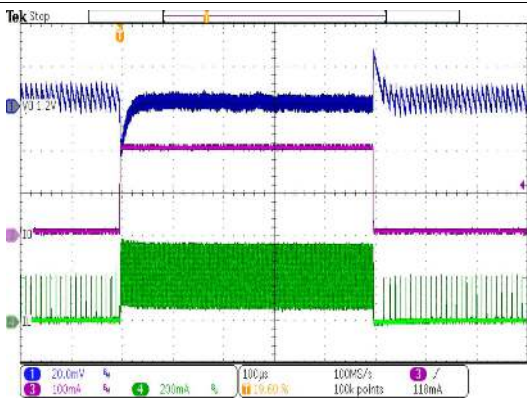

$V_{IN} = 3.6\text{ V}$
 $V_{OUT} = 1.2\text{ V}$
 $I_{OUT} = 5\text{ mA to } 200\text{ mA}$
 $1\ \mu\text{s Rise/Fall Time}$

Figure 20. Load Transient Performance

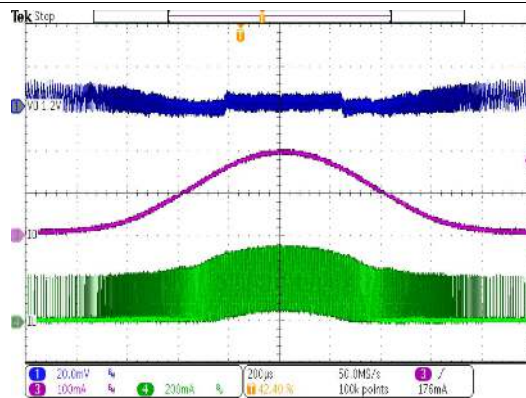

$V_{IN} = 3.6\text{ V}$
 $V_{OUT} = 1.2\text{ V}$
 $I_{OUT} = 5\text{ mA to } 200\text{ mA}$
 Sinusoidal I_{OUT} Sweep

Figure 21. AC Load Regulation Performance

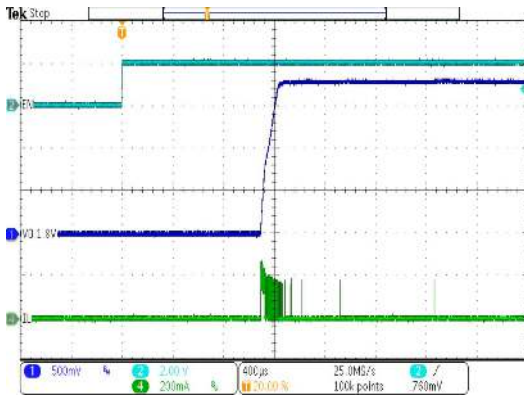

$V_{IN} = 3.6\text{ V}$
 $V_{OUT} = 1.8\text{ V}$
 $I_{OUT} = 0\text{ mA}$

Figure 22. Startup After EN High

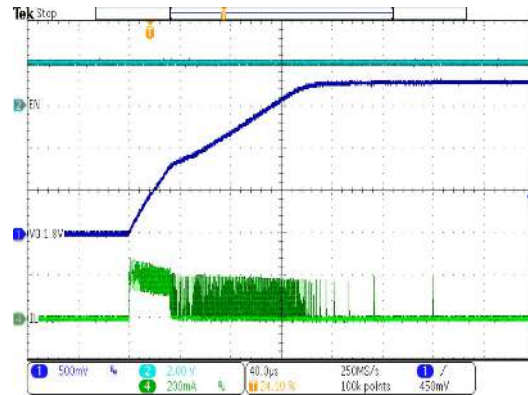

$V_{IN} = 3.6\text{ V}$
 $V_{OUT} = 1.8\text{ V}$
 $I_{OUT} = 0\text{ mA}$
 EN Altered from Low to High

Figure 23. VOUT Ramp Up

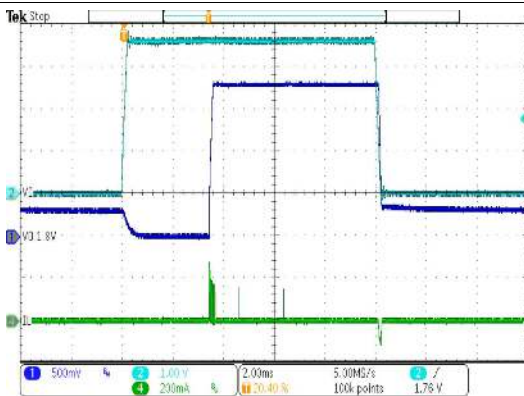

$V_{IN} = 0\text{ V to } 3.6\text{ V in } 100\text{ }\mu\text{s}$
 $V_{OUT} = 1.8\text{ V}$
 $I_{OUT} = 0\text{ mA}$
 $EN = V_{IN}$

Figure 24. VIN Ramp Up/Down

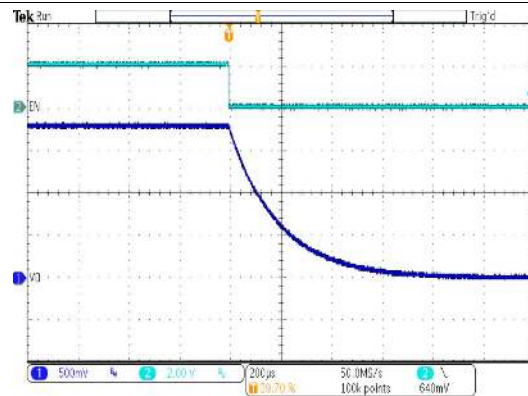

$V_{IN} = 3.6\text{ V}$
 $V_{OUT} = 1.8\text{ V}$
 $I_{OUT} = 0\text{ mA}$

Figure 25. Output Discharge

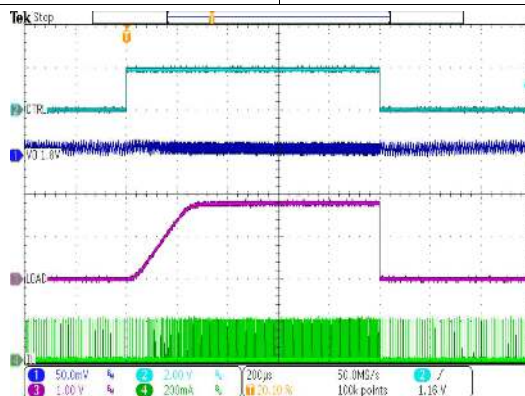

$V_{IN} = 3.6\text{ V}$
 $V_{OUT} = 1.8\text{ V}$
 $I_{OUT1} = 5\text{ mA}$
 $R_{LOAD} = 150\text{ }\Omega$

Figure 26. Output Load Enable/Disable

8.2.2 TPS62770 Step-Up Converter with Adjustable Output Voltage (9 V to 15 V)

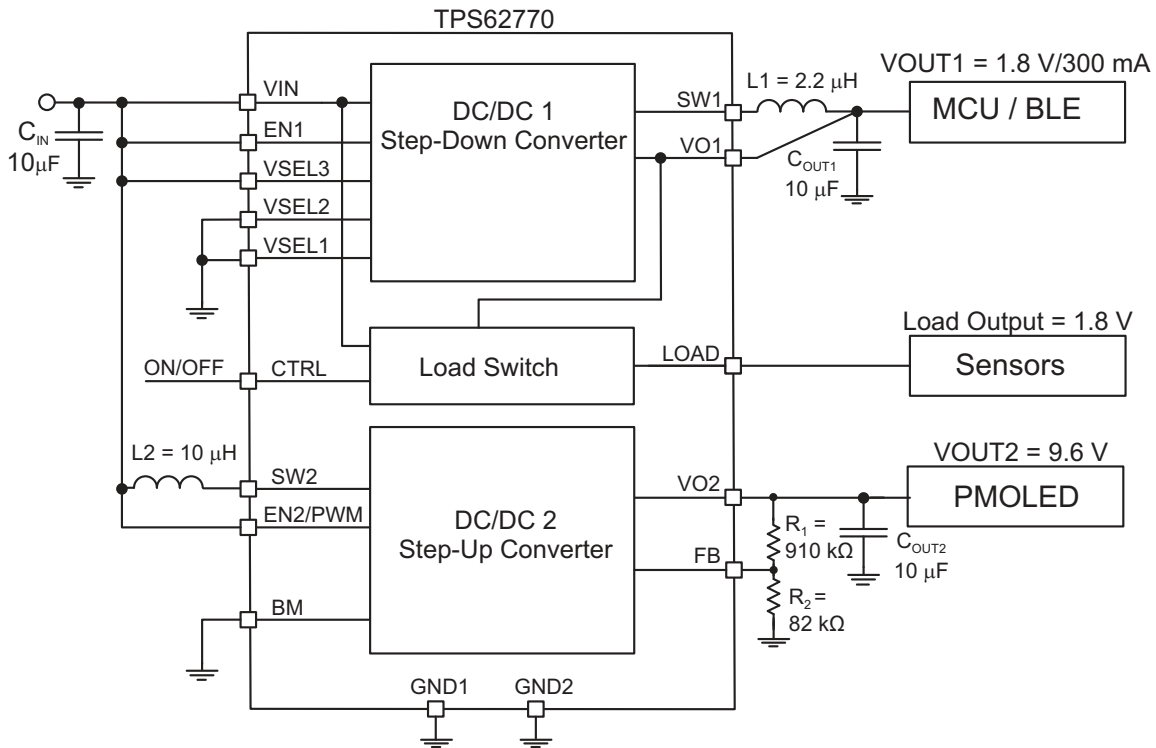

Copyright © Texas Instruments Incorporated

Figure 27. Schematic for Step-Up Converter with Adjustable Output Voltage (9V-15V)

8.2.2.1 Design Requirements

The LC output filter should meet the values shown in Table 5.

Table 5. Recommended LC Output Filter Combinations for Step-Up Converter

INDUCTOR VALUE [µH] ⁽¹⁾	VOUT	IOUT	OUTPUT CAPACITOR VALUE [µF] ⁽²⁾	
			10 µF	2 x 10µF
10	9 V – 15 V	(IOUT ≤ 30 mA)	√	√
		(IOUT ≤ 100 mA)		√ ⁽³⁾

- (1) Inductor tolerance and current de-rating is anticipated. The effective inductance can vary by 20% and -30%.
- (2) Capacitance tolerance and bias voltage de-rating is anticipated. The effective capacitance can vary by 20% and -50%.
- (3) This LC combination is the standard value and recommended for most applications.

8.2.2.2 Detailed Design Procedure

8.2.2.2.1 Programming the Output Voltage Of The Step-Up Converter

There are two ways to set the output voltage of the step-up converter. When the FB pin is connected to the input voltage, the output voltage is fixed to 12 V. This function reduces the external components to minimize the solution size. The second way is to use an external resistor divider to set the desired output voltage.

By selecting the external resistor divider R1 and R2, as shown in [Equation 5](#), the output voltage is programmed to the desired value. When the output voltage is regulated, the typical voltage at the FB pin is V_{REF} of 795 mV.

$$R1 = \left(\frac{V_{OUT}}{V_{REF}} - 1 \right) \times R2 \quad (5)$$

Where:

V_{OUT} is the desired output voltage

V_{REF} is the internal reference voltage at the FB pin

8.2.2.2.2 Inductor Selection for TPS62770 Step-Up Converter

The step-up converter is optimized to work with an inductor values of 10 μ H. Follow [Equation 6](#) to [Equation 8](#) to calculate the inductor's peak current for the application. To calculate the current in the worst case, use the minimum input voltage, maximum output voltage, and maximum load current of the application. To have enough design margin, choose the inductor value with -30% tolerance, and a low power-conversion efficiency for the calculation.

In a step-up regulator, the inductor dc current can be calculated with [Equation 6](#).

$$I_{L(DC)} = \frac{V_{OUT} \times I_{OUT}}{V_{IN} \times \eta} \quad (6)$$

Where:

V_{OUT} = output voltage

I_{OUT} = output current

V_{IN} = input voltage

η = power conversion efficiency, use 80% for most applications

The inductor ripple current is calculated with the [Equation 7](#) for an asynchronous step-up converter in continuous conduction mode (CCM).

$$\Delta I_{L(P-P)} = \frac{V_{IN} \times (V_{OUT} + 0.8V - V_{IN})}{L \times f_{SW} \times (V_{OUT} + 0.8V)} \quad (7)$$

Where:

$\Delta I_{L(P-P)}$ = inductor ripple current

L = inductor value

f_{SW} = switching frequency

V_{OUT} = output voltage

V_{IN} = input voltage

Therefore, the inductor peak current is calculated with [Equation 8](#).

$$I_{L(P)} = I_{L(DC)} + \frac{\Delta I_{L(P-P)}}{2} \quad (8)$$

The following inductor series from different suppliers have been used:

Table 6. List Of Inductors

CONVERTER	INDUCTANCE [μ H]	DIMENSIONS [mm^3]	INDUCTOR TYPE	SUPPLIER ⁽¹⁾	Output Current I_{OUT2}
Step-up	10	2.0x1.6x1.2	VLS201610	TDK	< 30mA
	10	3.0 x 2.5 x 1.5	VLS302515	TDK	< 100mA

(1) See [Third-party Products Disclaimer](#)

8.2.2.2.1 Example Step-Up Converter with 12-V Fixed Output

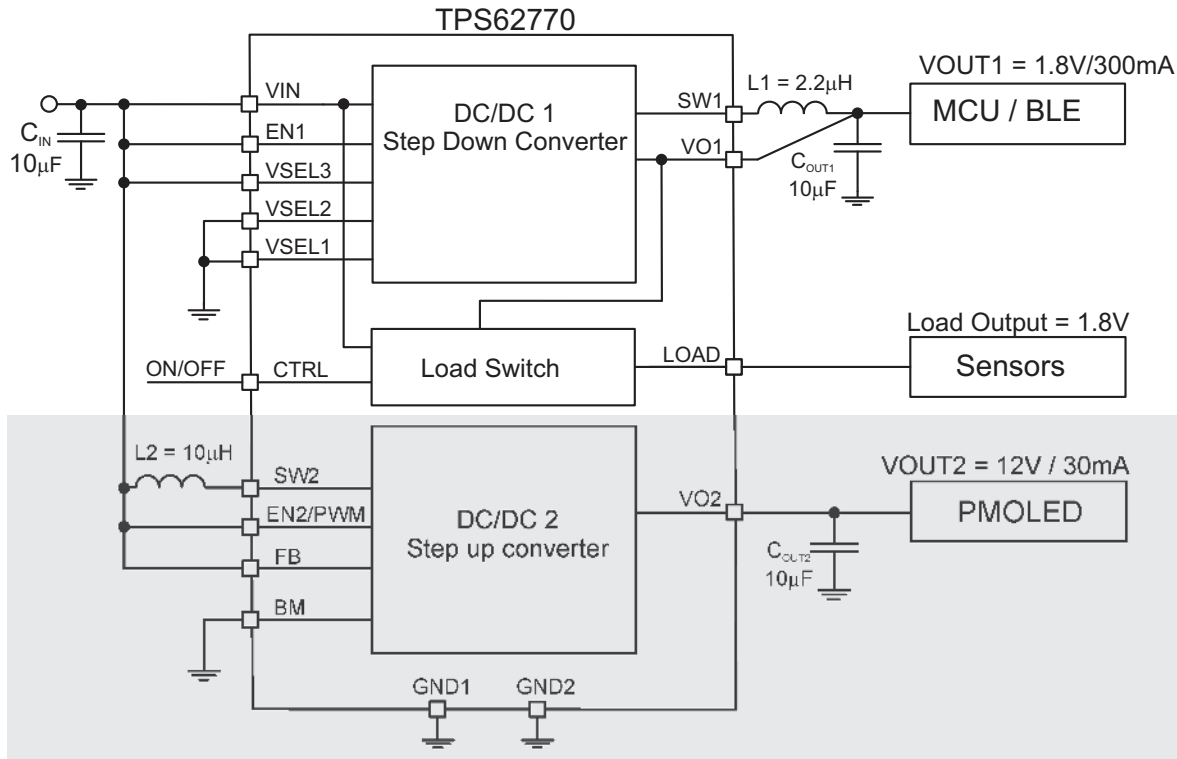

Figure 28. Schematic for a Step-Up Converter with Fixed 12-V Output

Table 7. Components for *Application Curves for Step-Up Converter*

REFERENCE	DESCRIPTION	VALUE	PACKAGE CODE / SIZE [mm x mm x mm]	MANUFACTURER ⁽¹⁾
CIN	Ceramic capacitor X5R 6.3V, GRM155R60J106ME11	10 µF	0402 / 1.0 x 0.5 x 0.5	Murata
COUT2	Ceramic capacitor X5R 25V, GRM188R61E106MA73	2 x 10 uF	0603 / 1.6 x 0.8 x 0.8	Murata
L2	Inductor VLS302515	10 µH	3.0 x 2.5 x 1.5	TDK

(1) See [Third-party Products Disclaimer](#)

8.2.2.3 Application Curves for Step-Up Converter

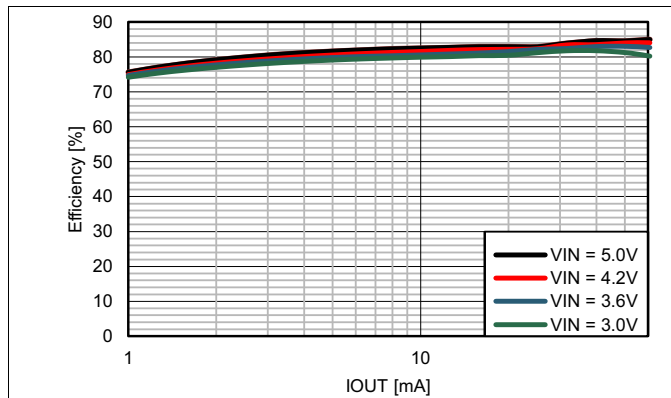

Figure 29. Efficiency vs. IOUT, VOUT = 15 V

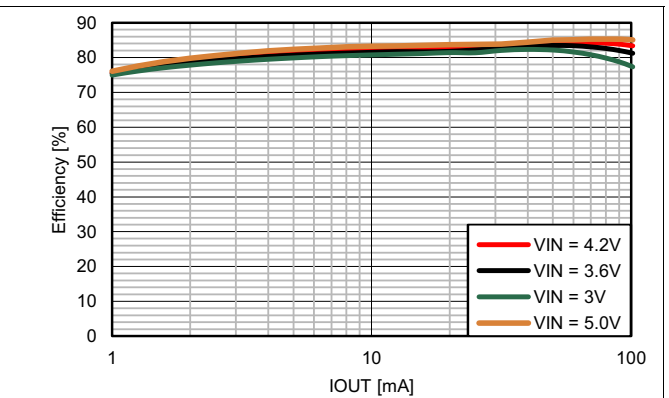

Figure 30. Efficiency vs. IOUT, VOUT = 12 V

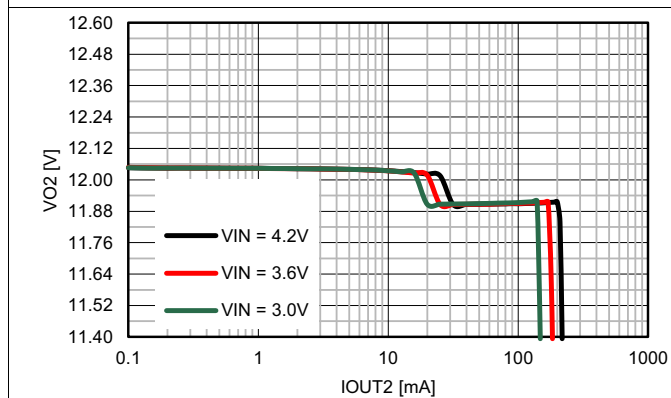
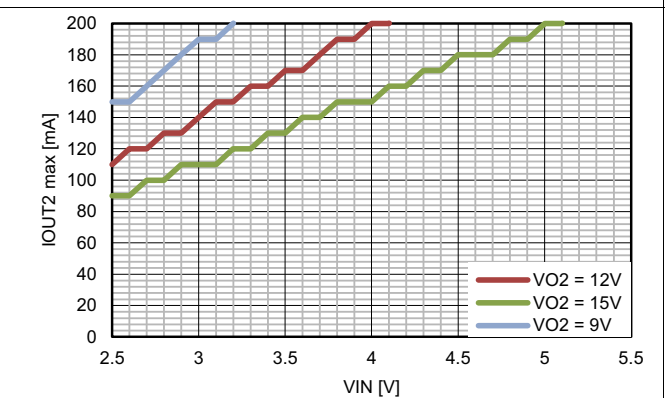
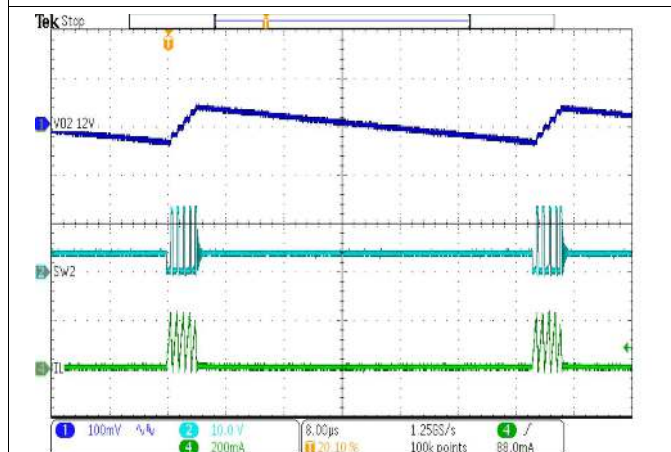

Figure 31. VOUT2 = 12 V vs IOUT2



TA = 25°C
 L = 10 μH
 Typical Switch Current Limit I_{LIM_SW}
 $I_{OUT2\ max}$ @ -3% VOUT Drop
 COUT2 = 2x 10 μF

Figure 32. Maximum Output Current vs VIN for Typical I_{LIMSW}



$V_{IN} = 3.6\ V$
 $V_{OUT} = 12\ V$
 $I_{OUT2} = 2\ mA$
 $L = 10\ \mu H$

Figure 33. Typical Operation PFM Mode

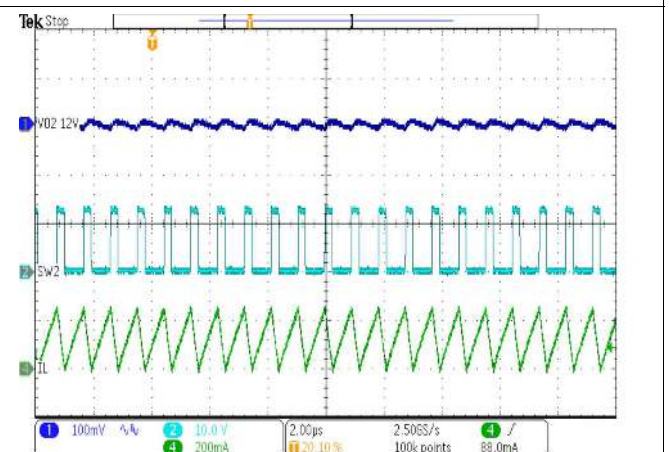

$V_{IN} = 3.6\ V$
 $V_{OUT} = 12\ V$
 $I_{OUT2} = 30\ mA$
 $L = 10\ \mu H$

Figure 34. Typical Operation PWM Mode

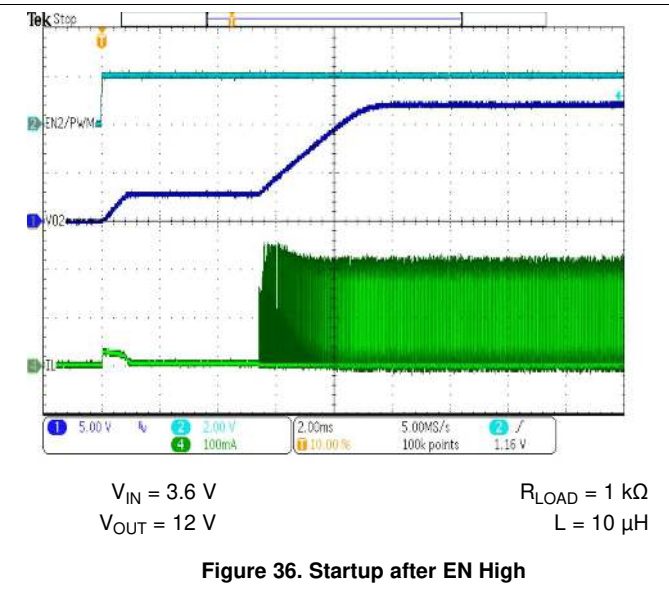
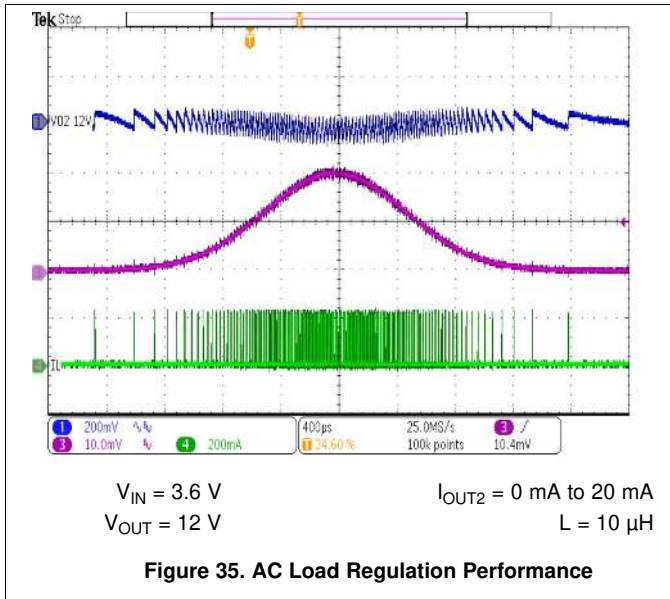

8.2.3 Step-Up Converter with Constant 5-V Output Voltage

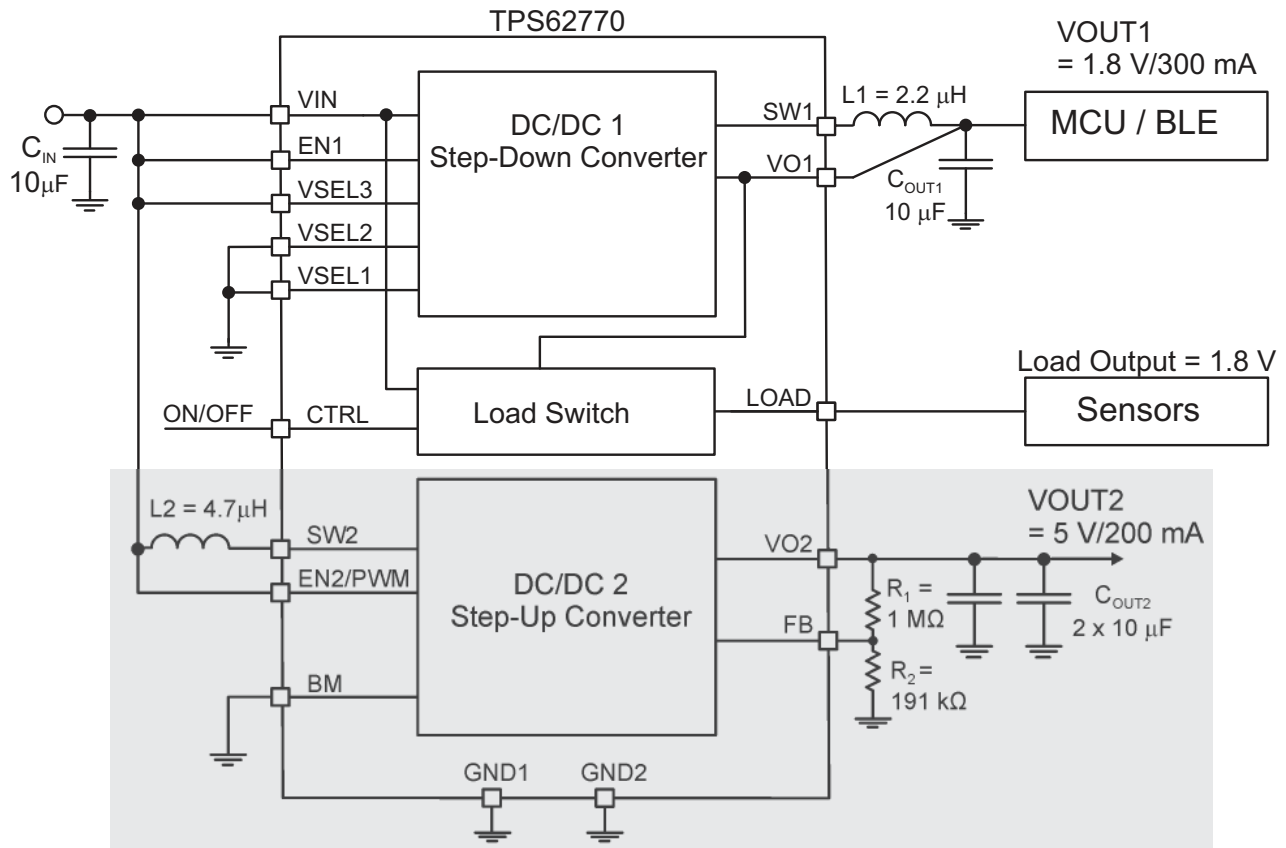

Copyright © 2016, Texas Instruments Incorporated

Figure 37. Step-Up Converter Providing 5V V_{OUT2}

8.2.3.1 Design Requirements

The LC output filter should meet the values shown in Table 8. For 5V Output voltage an inductor value of 4.7µH should be used for loop stability.

Table 8. Recommended LC Output Filter Combinations for Step-Up Converter

INDUCTOR VALUE [µH] ⁽¹⁾	VOUT	IOUT	OUTPUT CAPACITOR VALUE [µF] ⁽²⁾	
			10 µF	2 x 10µF
4.7	5 V	(IOUT ≤ 200 mA)		√ ⁽³⁾

- (1) Inductor tolerance and current de-rating is anticipated. The effective inductance can vary by 20% and -30%.
- (2) Capacitance tolerance and bias voltage de-rating is anticipated. The effective capacitance can vary by 20% and -50%.
- (3) This LC combination is the standard value and recommended for most applications.

8.2.3.2 Detailed Design Procedure

For setting the output voltage, see [Programming the Output Voltage Of The Step-Up Converter](#)

Table 9. Components for [Application Performance Curves](#)

REFERENCE	DESCRIPTION	VALUE	PACKAGE CODE / SIZE [mm x mm x mm]	MANUFACTURER ⁽¹⁾
CIN	Ceramic capacitor X5R 6.3V, GRM155R60J106ME11	10 μ F	0402 / 1.0 x 0.5 x 0.5	Murata
COU2 (2x)	Ceramic capacitor X5R 6.3V, GRM188R60J106ME84	10 μ F	0603 / 1.6 x 0.8 x 0.8	Murata
L2	Inductor VLS302515	4.7 μ H	3.0 x 2.5 x 1.5	TDK

(1) See [Third-party Products Disclaimer](#)

8.2.3.3 Application Performance Curves

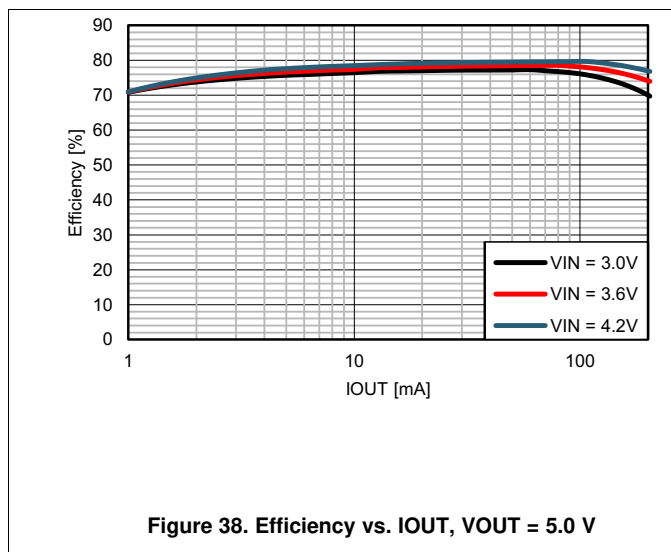

Figure 38. Efficiency vs. IOUT, VOUT = 5.0 V

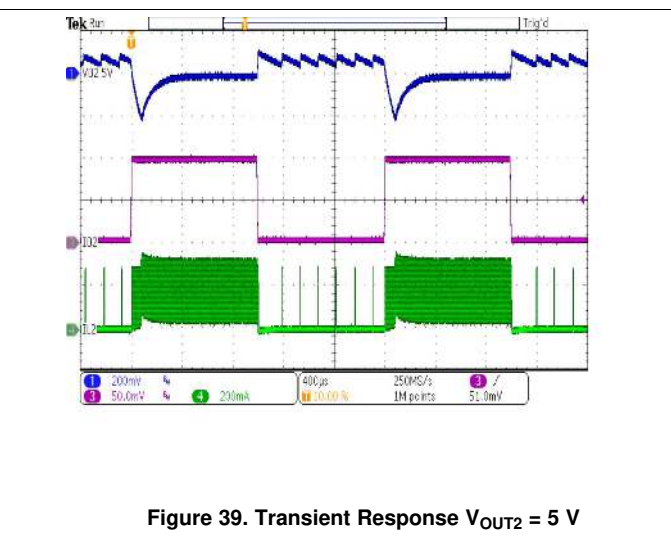
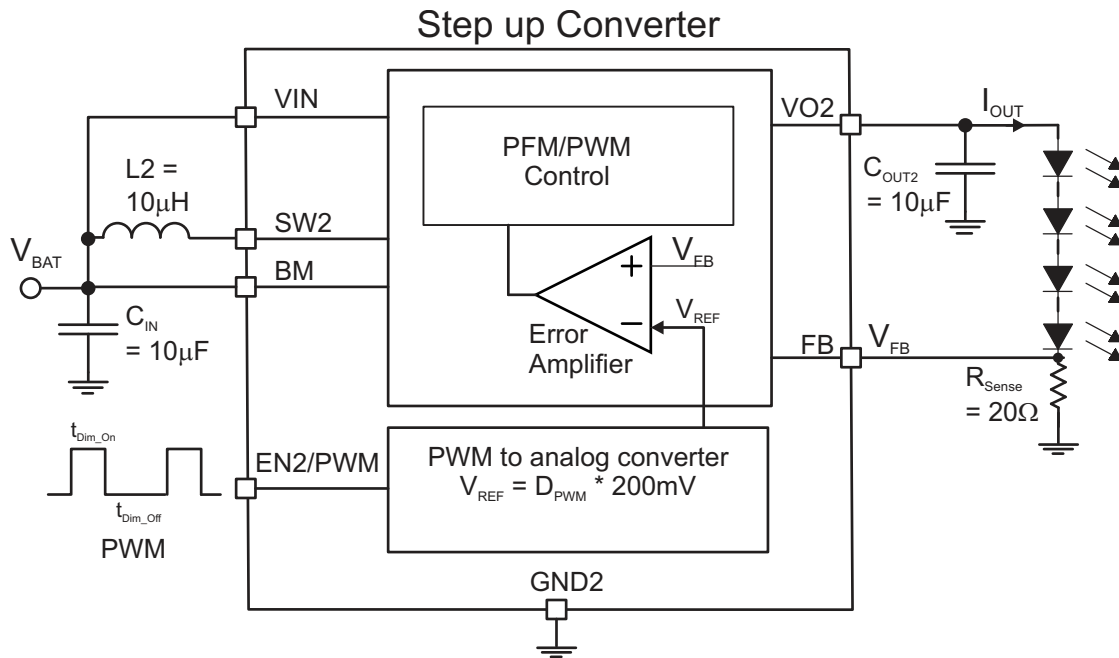

Figure 39. Transient Response VOUT2 = 5 V

8.2.4 Typical Step Up Converter with Constant Output Current



Copyright © 2016, Texas Instruments Incorporated

Figure 40. Step-Up Converter with Constant Output Current

8.2.4.1 Design Requirements

The step-up converter is configured to operate as a constant current driver e.g. to power 3 to 4 white LED's in a string. The maximum current through the string is set by the sense resistor R_{Sense} as shown in Figure 40. To minimize the losses in the sense resistor, the device features a 200mV internal reference, which is enabled by connecting the BM pin to high level. This section describes an application delivering 10mA through an LED string with 4 LED's which is suitable for small display used in wearable applications. See also [TPS62770 Step-Up Converter with Adjustable Output Voltage \(9 V to 15 V\)](#) section *Design Requirements*.

8.2.4.2 Detailed Design Procedure

8.2.4.2.1 Setting the Output Current

The Sense resistor to set the maximum output current can be calculated according to Equation 9. The output current I_{OUT2} can be reduced by applying a PWM signal at pin EN2/PWM according to Equation 10.

$$R_{Sense} = \frac{200 \text{ mV}}{I_{OUT2}} \quad (9)$$

$$I_{OUT2} = D_{PWM} \times \frac{200 \text{ mV}}{R_{Sense}} \quad (10)$$

Where:

R_{Sense} = sense resistor in [Ω]

I_{OUT2} = output current in [mA]

D_{PWM} = Dutycycle of the PWM signal at pin EN2/PWM

8.2.4.2.2 Inductor Selection

See [Inductor Selection for TPS62770 Step-Up Converter](#)

Table 10. Components for *Application Curves*

REFERENCE	DESCRIPTION	VALUE	PACKAGE CODE / SIZE [mm x mm x mm]	MANUFACTURER ⁽¹⁾
CIN	Ceramic capacitor X5R 6.3V, GRM155R60J106ME11	10 μ F	0402 / 1.0 x 0.5 x 0.5	Murata
COUT2	Ceramic capacitor X5R 25V, GRM188R61E106MA73	10 μ F	0603 / 1.6 x 0.8 x 0.8	Murata
L2	Inductor VLS302515	10 μ H	3.0 x 2.5 x 1.5	TDK
R _{Sense}	Resistor 1%	20 Ω	0402/ 1.0 x 0.5 x 0.5	Vishay
D1-D4	LED LTW-E670DS	n/a		Lite ON

(1) See [Third-party Products Disclaimer](#)

8.2.4.3 Application Curves

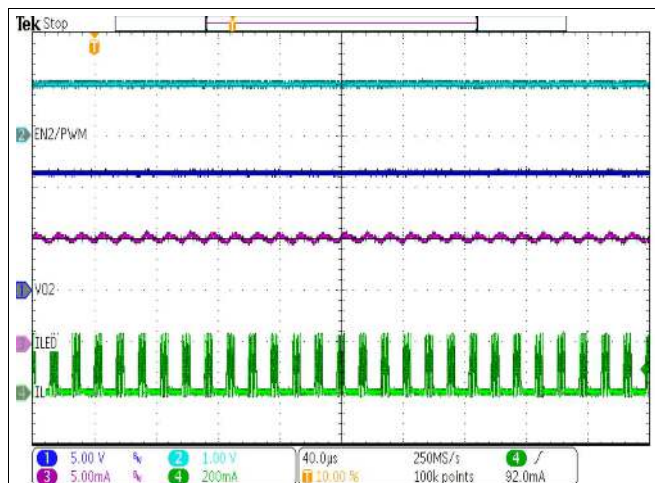

$V_{IN} = 3.6\text{ V}$
 $R_{Sense} = 20\ \Omega$
 EN2/PWM = High
 4 LEDs in Series
 $D = 100\%$, $I_{LED} = 10\text{ mA}$
 $L = 10\ \mu\text{H}$

Figure 41. Constant Current Operation with EN2/PWM = 100% D

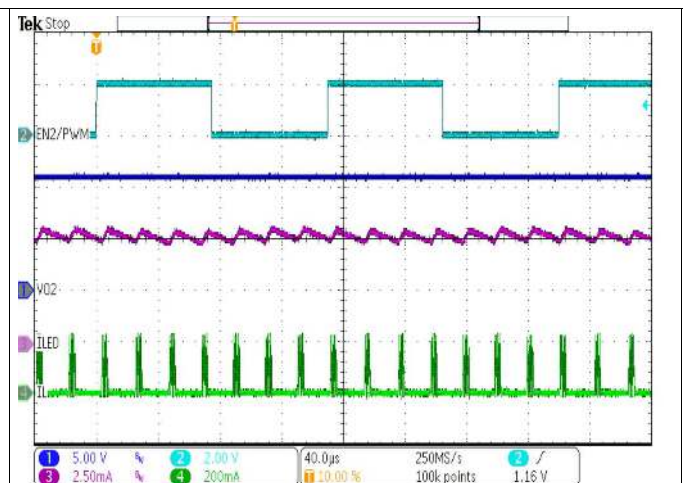

$V_{IN} = 3.6\text{ V}$
 $R_{Sense} = 20\ \Omega$
 $t_{Dim_On} = 75\ \mu\text{s}$, $t_{Dim_Off} = 75\ \mu\text{s}$
 4 LEDs in Series
 $D = 50\%$, $T_{Dim} = 140\ \mu\text{s}$, $I_{LED} = 5\text{ mA}$
 $L = 10\ \mu\text{H}$

Figure 42. Constant Current with EN2/PWM = 50% D

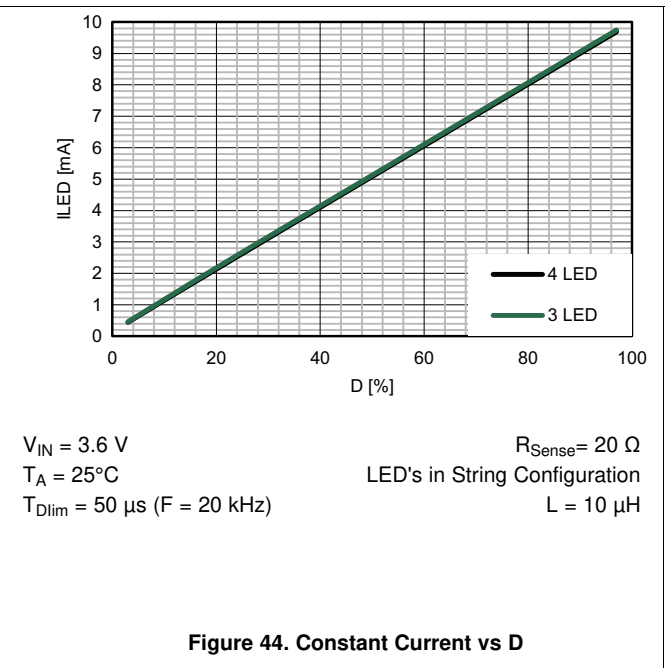
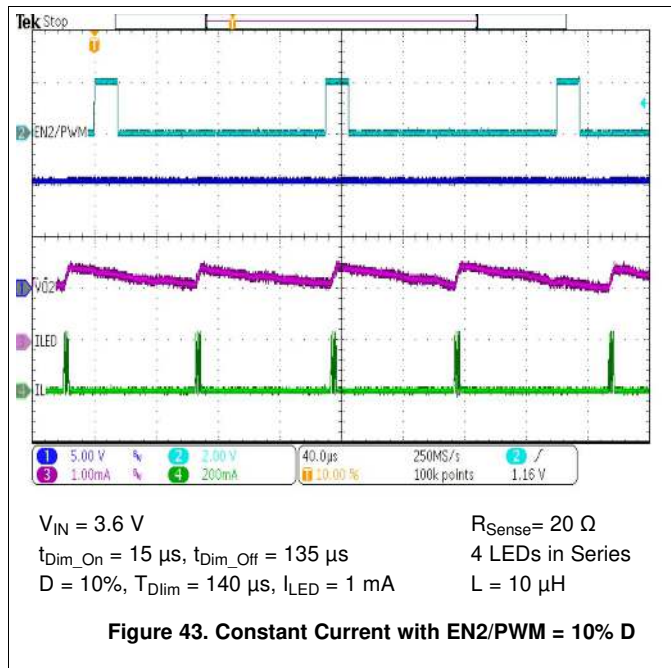

9 Power Supply Recommendations

The power supply must provide a current rating according to the supply voltage, output voltage and output current of the TPS62770.

10 Layout

10.1 Layout Guidelines

- As for all switching power supplies, the layout is an important step in the design. Care must be taken in board layout to get the specified performance.
- If the layout is not carefully done, the regulator could show poor line and/or load regulation, stability issues as well as EMI problems and interference with RF circuits.
- It is critical to provide a low inductance, impedance ground path. Therefore, use wide and short traces for the main current paths.
- The input capacitor should be placed as close as possible to the IC pins VIN and GND. The output capacitors should be placed close between VO1/2 and GND pins.
- The VO1/2 line should be connected to the output capacitor and routed away from noisy components and traces (e.g. SW line) or other noise sources.
- See [Figure 45](#) and [Figure 46](#) for the recommended PCB layout.

10.2 Layout Example

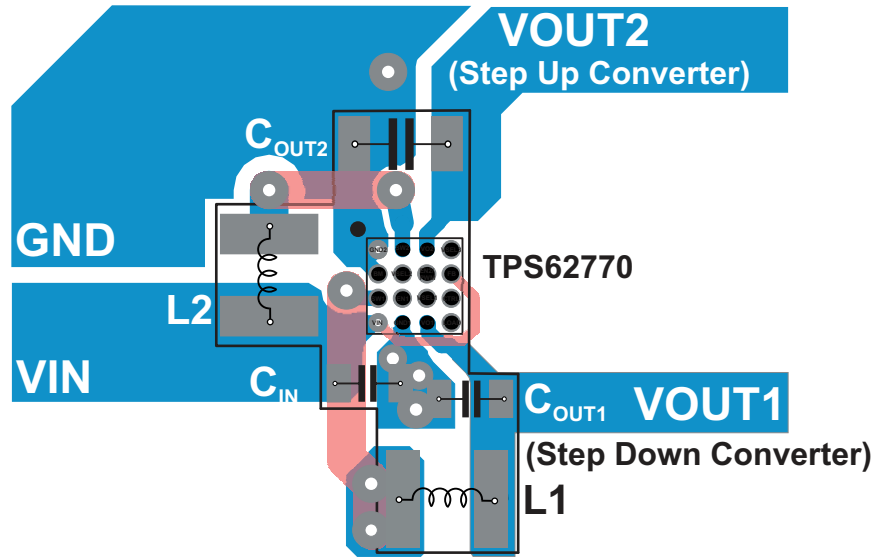

Figure 45. Recommended PCB Layout with 12 V Fixed VOUT2

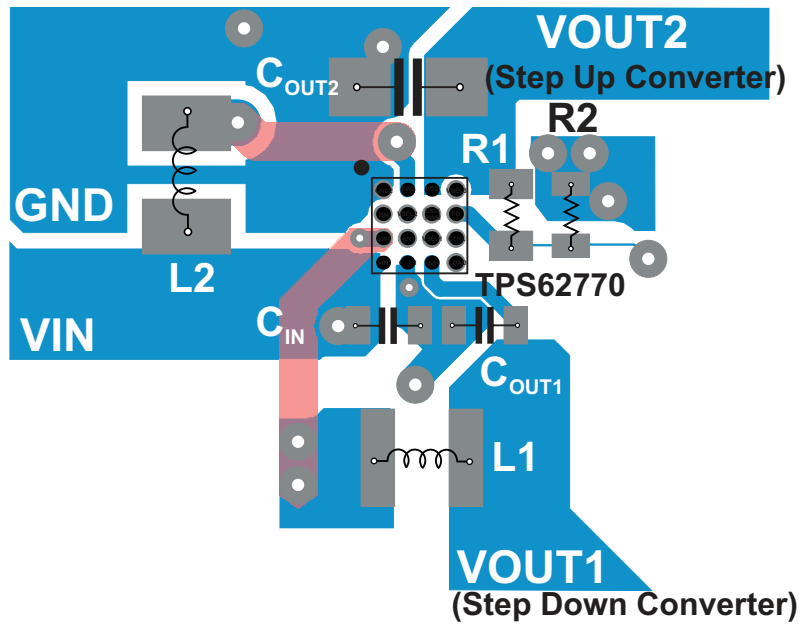

Figure 46. Recommended PCB Layout with Adjustable VOUT2

11 Device and Documentation Support

11.1 Device Support

11.1.1 Third-Party Products Disclaimer

TI'S PUBLICATION OF INFORMATION REGARDING THIRD-PARTY PRODUCTS OR SERVICES DOES NOT CONSTITUTE AN ENDORSEMENT REGARDING THE SUITABILITY OF SUCH PRODUCTS OR SERVICES OR A WARRANTY, REPRESENTATION OR ENDORSEMENT OF SUCH PRODUCTS OR SERVICES, EITHER ALONE OR IN COMBINATION WITH ANY TI PRODUCT OR SERVICE.

11.2 Documentation Support

11.2.1 Related Documentation

See also *TPS62770EVM-734 Evaluation Module User's Guide*, [SLVUAO2](#) and application note *Accurately measuring efficiency of ultralow-IQ devices*, [SLYT558](#).

11.3 Trademarks

DCS-Control is a trademark of Texas Instruments.
All other trademarks are the property of their respective owners.

11.4 Electrostatic Discharge Caution



These devices have limited built-in ESD protection. The leads should be shorted together or the device placed in conductive foam during storage or handling to prevent electrostatic damage to the MOS gates.

11.5 Glossary

[SLYZ022](#) — *TI Glossary*.

This glossary lists and explains terms, acronyms, and definitions.

12 Mechanical, Packaging, and Orderable Information

The following pages include mechanical, packaging, and orderable information. This information is the most current data available for the designated devices. This data is subject to change without notice and revision of this document. For browser-based versions of this data sheet, refer to the left-hand navigation.

PACKAGING INFORMATION

Orderable Device	Status (1)	Package Type	Package Drawing	Pins	Package Qty	Eco Plan (2)	Lead finish/ Ball material (6)	MSL Peak Temp (3)	Op Temp (°C)	Device Marking (4/5)	Samples
TPS62770YFPR	ACTIVE	DSBGA	YFP	16	3000	RoHS & Green	SNAGCU	Level-1-260C-UNLIM	-40 to 85	62770	Samples
TPS62770YFPT	ACTIVE	DSBGA	YFP	16	250	RoHS & Green	SNAGCU	Level-1-260C-UNLIM	-40 to 85	62770	Samples

(1) The marketing status values are defined as follows:

ACTIVE: Product device recommended for new designs.

LIFEBUY: TI has announced that the device will be discontinued, and a lifetime-buy period is in effect.

NRND: Not recommended for new designs. Device is in production to support existing customers, but TI does not recommend using this part in a new design.

PREVIEW: Device has been announced but is not in production. Samples may or may not be available.

OBSOLETE: TI has discontinued the production of the device.

(2) **RoHS:** TI defines "RoHS" to mean semiconductor products that are compliant with the current EU RoHS requirements for all 10 RoHS substances, including the requirement that RoHS substance do not exceed 0.1% by weight in homogeneous materials. Where designed to be soldered at high temperatures, "RoHS" products are suitable for use in specified lead-free processes. TI may reference these types of products as "Pb-Free".

RoHS Exempt: TI defines "RoHS Exempt" to mean products that contain lead but are compliant with EU RoHS pursuant to a specific EU RoHS exemption.

Green: TI defines "Green" to mean the content of Chlorine (Cl) and Bromine (Br) based flame retardants meet JS709B low halogen requirements of <=1000ppm threshold. Antimony trioxide based flame retardants must also meet the <=1000ppm threshold requirement.

(3) MSL, Peak Temp. - The Moisture Sensitivity Level rating according to the JEDEC industry standard classifications, and peak solder temperature.

(4) There may be additional marking, which relates to the logo, the lot trace code information, or the environmental category on the device.

(5) Multiple Device Markings will be inside parentheses. Only one Device Marking contained in parentheses and separated by a "~" will appear on a device. If a line is indented then it is a continuation of the previous line and the two combined represent the entire Device Marking for that device.

(6) Lead finish/Ball material - Orderable Devices may have multiple material finish options. Finish options are separated by a vertical ruled line. Lead finish/Ball material values may wrap to two lines if the finish value exceeds the maximum column width.

Important Information and Disclaimer:The information provided on this page represents TI's knowledge and belief as of the date that it is provided. TI bases its knowledge and belief on information provided by third parties, and makes no representation or warranty as to the accuracy of such information. Efforts are underway to better integrate information from third parties. TI has taken and continues to take reasonable steps to provide representative and accurate information but may not have conducted destructive testing or chemical analysis on incoming materials and chemicals. TI and TI suppliers consider certain information to be proprietary, and thus CAS numbers and other limited information may not be available for release.

In no event shall TI's liability arising out of such information exceed the total purchase price of the TI part(s) at issue in this document sold by TI to Customer on an annual basis.

YFP (S-XBGA-N16)

DIE-SIZE BALL GRID ARRAY

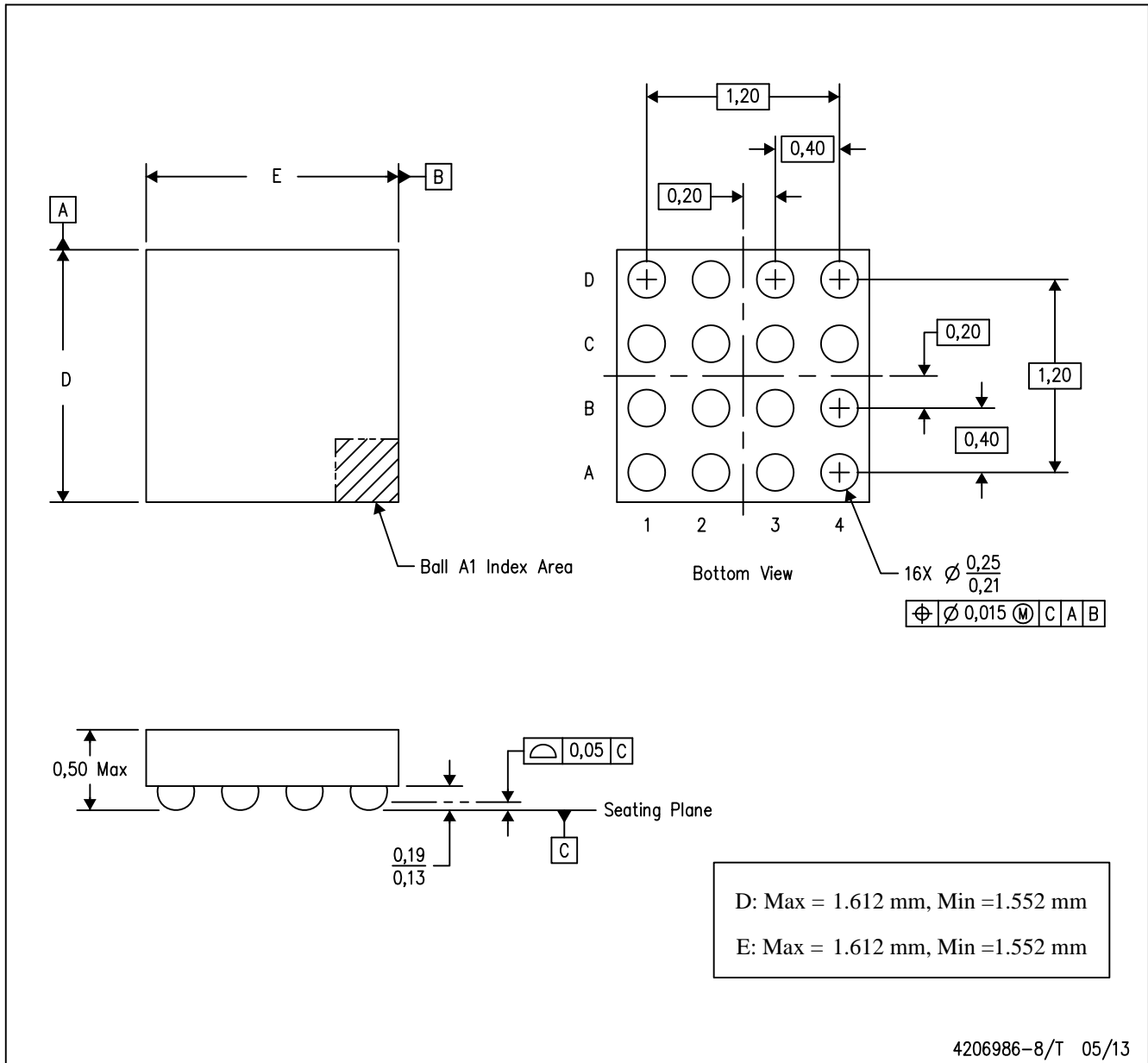

- NOTES:
- A. All linear dimensions are in millimeters. Dimensioning and tolerancing per ASME Y14.5M-1994.
 - B. This drawing is subject to change without notice.
 - C. NanoFree™ package configuration.

IMPORTANT NOTICE AND DISCLAIMER

TI PROVIDES TECHNICAL AND RELIABILITY DATA (INCLUDING DATA SHEETS), DESIGN RESOURCES (INCLUDING REFERENCE DESIGNS), APPLICATION OR OTHER DESIGN ADVICE, WEB TOOLS, SAFETY INFORMATION, AND OTHER RESOURCES "AS IS" AND WITH ALL FAULTS, AND DISCLAIMS ALL WARRANTIES, EXPRESS AND IMPLIED, INCLUDING WITHOUT LIMITATION ANY IMPLIED WARRANTIES OF MERCHANTABILITY, FITNESS FOR A PARTICULAR PURPOSE OR NON-INFRINGEMENT OF THIRD PARTY INTELLECTUAL PROPERTY RIGHTS.

These resources are intended for skilled developers designing with TI products. You are solely responsible for (1) selecting the appropriate TI products for your application, (2) designing, validating and testing your application, and (3) ensuring your application meets applicable standards, and any other safety, security, regulatory or other requirements.

These resources are subject to change without notice. TI grants you permission to use these resources only for development of an application that uses the TI products described in the resource. Other reproduction and display of these resources is prohibited. No license is granted to any other TI intellectual property right or to any third party intellectual property right. TI disclaims responsibility for, and you will fully indemnify TI and its representatives against, any claims, damages, costs, losses, and liabilities arising out of your use of these resources.

TI's products are provided subject to [TI's Terms of Sale](#) or other applicable terms available either on [ti.com](https://www.ti.com) or provided in conjunction with such TI products. TI's provision of these resources does not expand or otherwise alter TI's applicable warranties or warranty disclaimers for TI products.

TI objects to and rejects any additional or different terms you may have proposed.

Mailing Address: Texas Instruments, Post Office Box 655303, Dallas, Texas 75265
Copyright © 2023, Texas Instruments Incorporated