

THIS DRAWING IS UNPUBLISHED. RELEASED FOR PUBLICATION
 © COPYRIGHT - By - ALL RIGHTS RESERVED.

LOC	DIST	REVISIONS					
G	14	P	LTR	DESCRIPTION	DATE	DWN	APVD
		G2		REVISED PER ECO-11-005027	11MAR11	RK	HMR

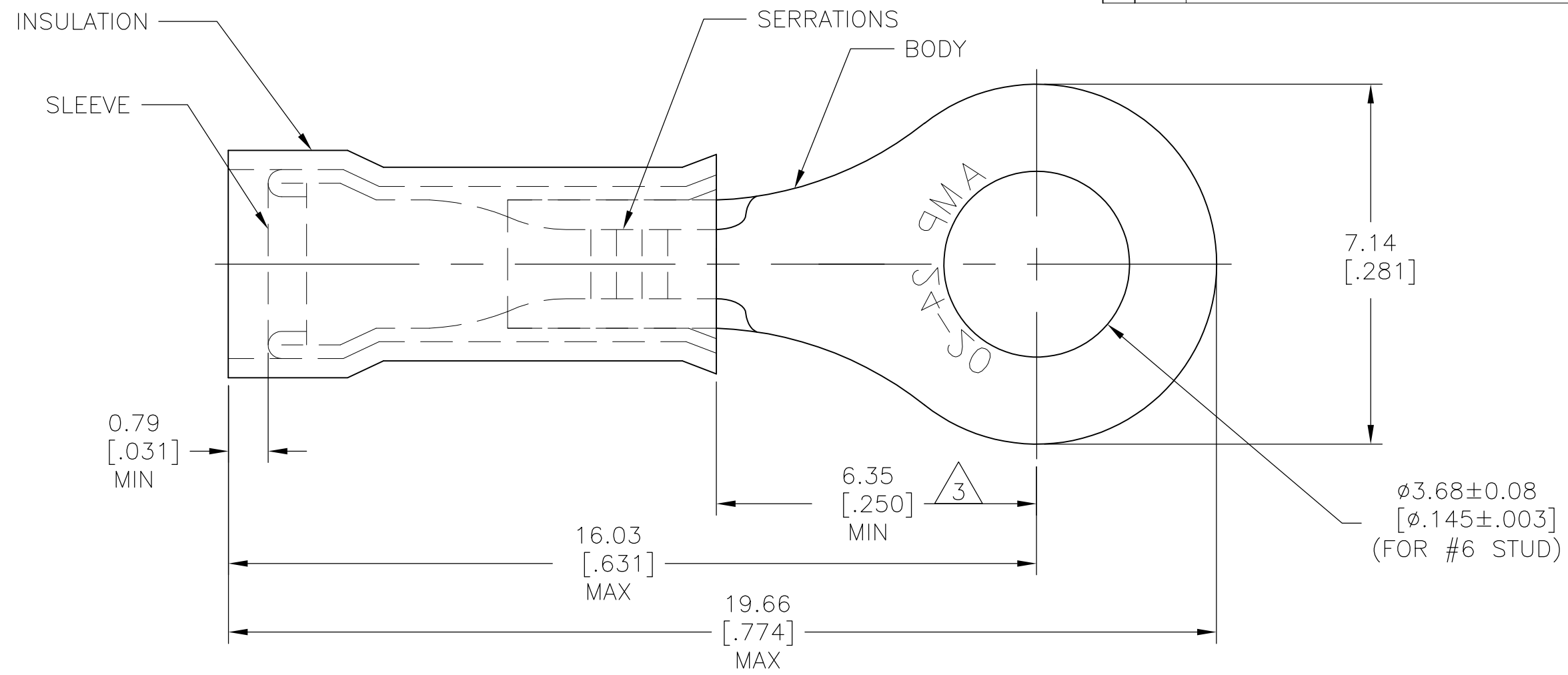

- 1 FOR 1.02[.040] TO 2.54[.100] WIRE INSULATION DIA
- 2 TONGUE MATERIAL THK 0.58±0.05[.023±.002]
- 3 APPLIES FROM EDGE OF METAL BARREL TO CENTERLINE OF STUD HOLE.

1	2-323986-2 ON TAPE	BODY&SLEEVE: COPPER ASTM-B152 TIN PL ASTM-B545	2-323986-3
1	WIRE TERMINAL	INSULATION: BLACK NYLON ASTM-D4066 TYPE I	2-323986-2
1	323986 ON TAPE	BODY&SLEEVE: COPPER ASTM-B152 TIN PL ASTM-B545	2-323986-1
1	WIRE TERMINAL	INSULATION: NATURAL NYLON ASTM-D4066 TYPE I	323986
QTY	DESCRIPTION	MATERIAL & FINISH	PART NO

THIS DRAWING IS A CONTROLLED DOCUMENT.		DWN RAGHAVENDRA 19MAR10	STE TE Connectivity	
DIMENSIONS: mm [INCHES]		CHK JEFF RUTH 19MAR10		
TOLERANCES UNLESS OTHERWISE SPECIFIED:		APVD TOM MICHIELUTTI 19MAR10	NAME	
0 PLC ± -		PRODUCT SPEC	TERMINAL, NYLON - PIDG - RING TONGUE	
1 PLC ± -		APPLICATION SPEC	WIRE SIZE: 24-20	
2 PLC ± -		WEIGHT	SIZE	CAGE CODE
3 PLC ± 0.20 [.008]		—	A3	00779
4 PLC ± -		FINISH	DRAWING NO	RESTRICTED TO
ANGLES ± 0° 30'		SEE TABLE	C-323986	—
MATERIAL	SEE TABLE	CUSTOMER DRAWING	SCALE	SHEET
			10:1	1 OF 1
			REV	G2