

SPECIFICATION FOR DYNAMIC SPEAKER

TOTAL PAGE 09

www.be-star.com

RoHS

Customer		Model Name	BLS2035-11-08H7.6W153 LF
Customer P/N		Product No.	120124
Date	05 Sep .2019	Issue No.	BS/TES01.1770C1
Page	01 of 09	Issue Date	2019/09/05

Approval:

- 1.Description
- 2.Characteristics
- 3.Drawing
- 4.Reliability Test
- 5.Packing
- 6.History Change Record

Drawn by	Checked by	Approved by	Customer approved
杨紫群	任江凤	张勇磊	

BESTAR Holdings Co., Ltd.

No.199, West Huanghe Road, Changzhou, Jiangsu, P.R. China

Tel: +86 5196 789 6200

Fax: +86 5196 789 6220

E-Mail: Info@be-star.com

Web: www.be-star.com

BLS2035-11-08H7.6W153 LF

1. Description

- 1.1 Acoustic component Performance Specification
- 1.2 The present document specifies performance requirements for the acoustic characteristics of speaker

2. Characteristics

2.1 Electrical and Mechanical Characteristics

No.	Item	Specification
1.	Dimension	20 x 35 x 7.6(mm)
2.	AC Impedance	$8 \Omega \pm 15\%$ at 1.0KHz
3.	Rated Input Power	2.0W
4.	Maximum Input Power	3.5W
5.	Resonance Frequency	800Hz \pm 20%
6.	Frequency Response	F0~10KHz
7.	S.P.L	88 \pm 3dB/0.1W /0.1m at 0.8,1.0,1.2,1.5KHz average
8.	T.H.D	$\leq 10\%$ at 2.0W/1KHz
9.	Magnet	$\varnothing 11.5 \times 1.5$ mm
10.	Buzzes & Rattles	Must be normal at sine wave 4.0Vrms
11.	Polarity	Positive voltage to (+),Diaphragm moves forward
12.	Operating Temperature	-40~+ 85°C
13.	Storage Temperature	-40~+ 85°C

2.2 Test Method

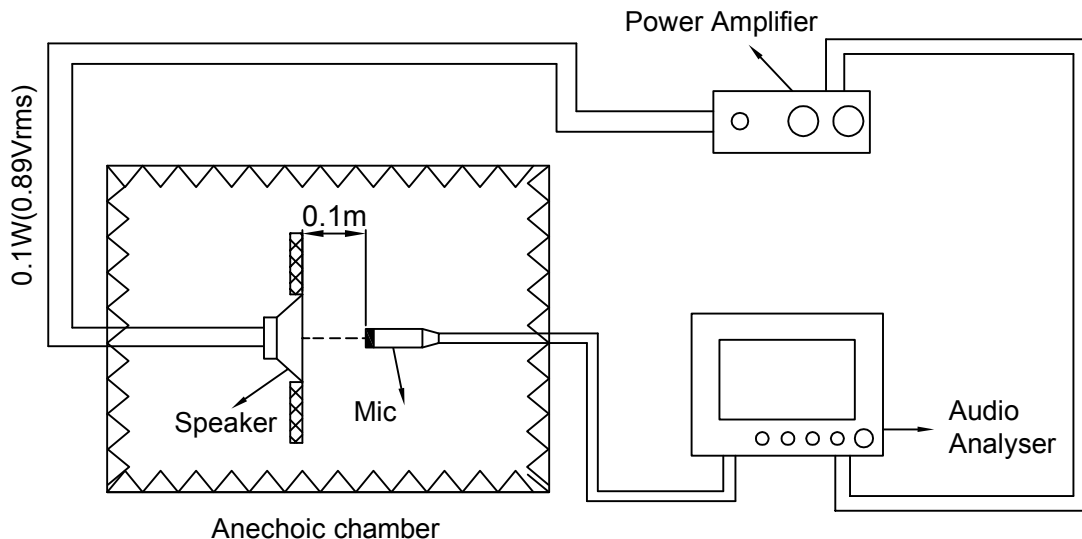

This print and information there in are proprietary to BESTAR Holdings Co., Ltd. and shall not be used in whole or in part without its written content

				Date:	2019/09/05	BLS2035-11-08H7.6W153 LF	
				Drawn by:	杨紫群		
C1	2019/09/05	杨紫群		Checked by:	任江凤	Speaker	
Rev.	Date	Drawn	Note	Approved by:	张勇磊		
BESTAR Holdings Co., Ltd						DRG NO: BS/TES01.1770C1	Page:02 of 09
http://www.be-star.com info@be-star.com							

BLS2035-11-08H7.6W153 LF

2.3 Frequency Response Curve (only for reference)

A: Frequency Response Magn 0 dB re 20.00 μ Pa/V 1/12Oct

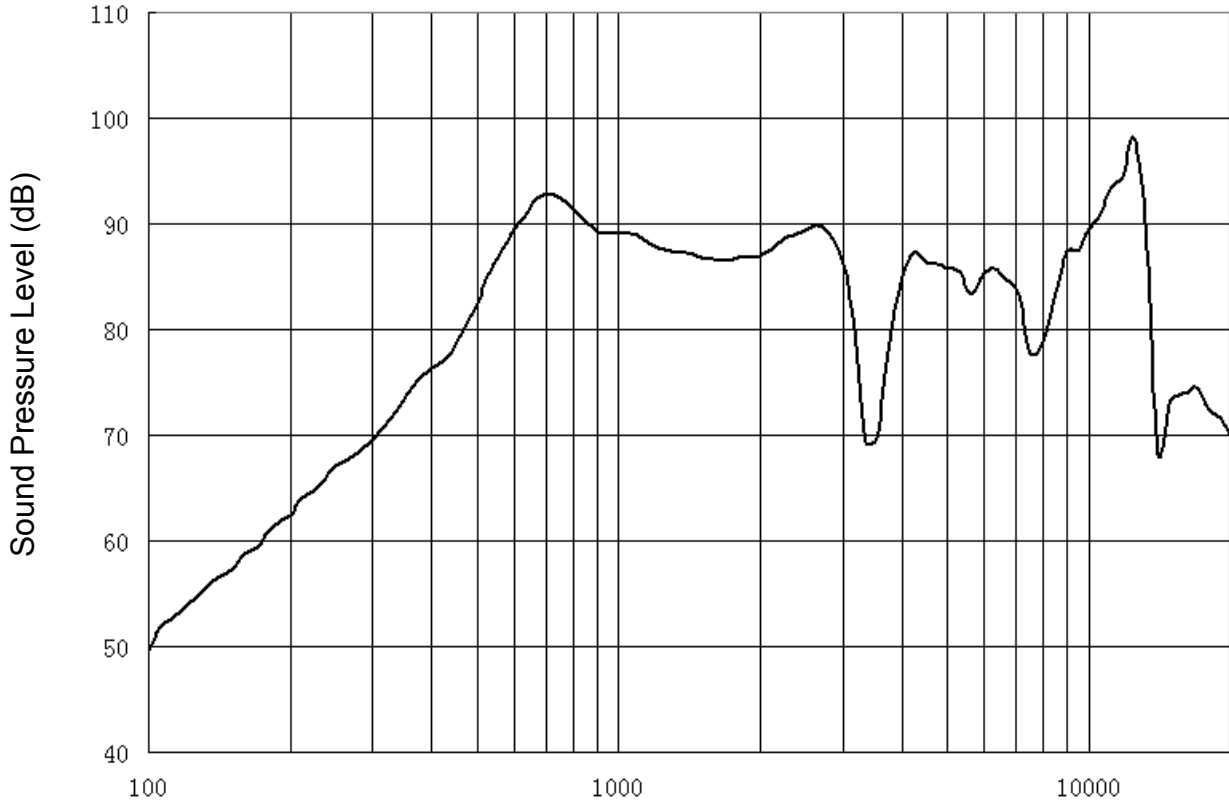

2.3.1 Sensitivity

SPL is expressed in dB rel 20 μ Pa, computed according to IEC 268-5.
 Measurement set up according chapter 2.2 and parameters according chapter 2.3.

This print and information there in are proprietary to B ESTAR Holdings Co., Ltd. and shall not be used in whole or in part without its written content

				Date:	2019/09/05	BLS2035-11-08H7.6W153 LF	
				Drawn by:	杨紫群		
C1	2019/09/05	杨紫群		Checked by:	任江凤	Speaker	
Rev.	Date	Drawn	Note	Approved by:	张勇磊		
BESTAR Holdings Co., Ltd						DRG NO: BS/TES01.1770C1	Page:03 of 09
http://www.be-star.com info@be-star.com							

BLS2035-11-08H7.6W153 LF

2.4 Frequency Response Curve (only for reference)

A: Frequency Response Magn 0 dB re 20.00 μ Pa/V 1/12Oct

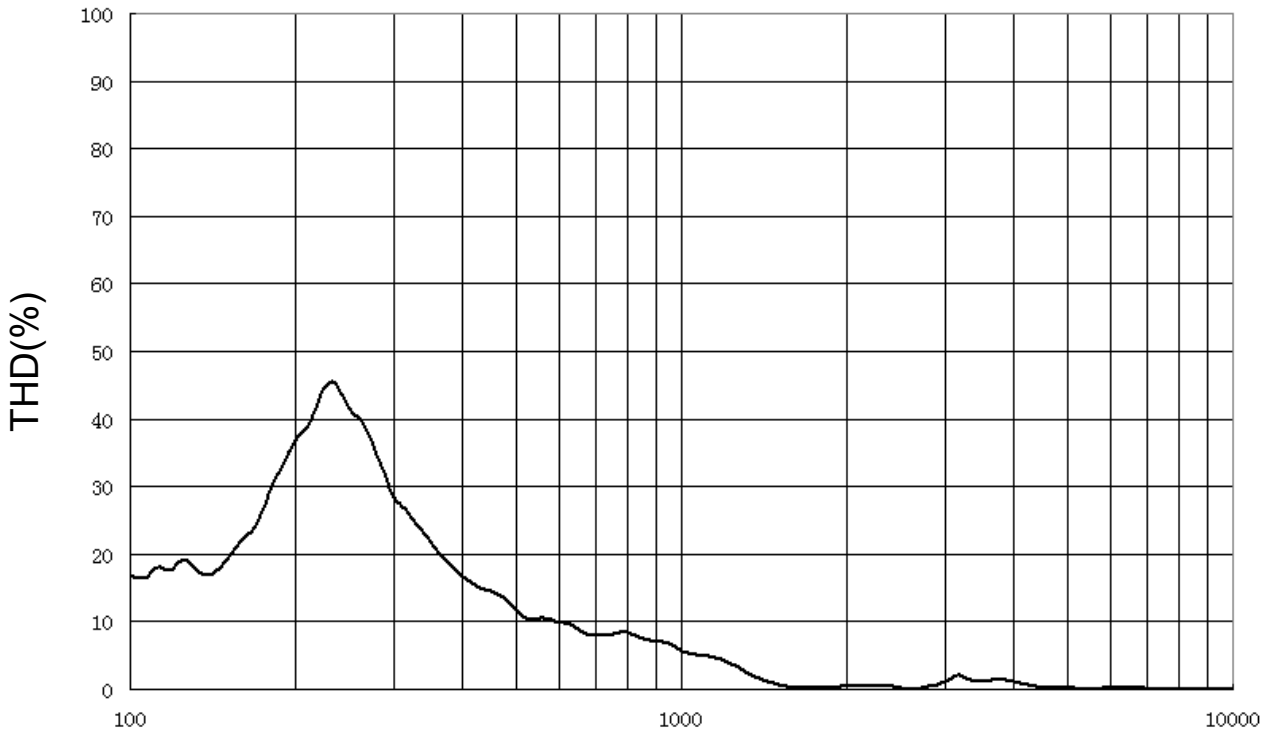

4.5.1 THD

THD is measured according test set up in chapter 2.2 and parameters according chapter 2.4

This print and information there in are proprietary to BESTAR Holdings Co., Ltd. and shall not be used in whole or in part without its written content

				Date:	2019/09/05	BLS2035-11-08H7.6W153 LF	
				Drawn by:	杨紫群		
C1	2019/09/05	杨紫群		Checked by:	任江凤	Speaker	
Rev.	Date	Drawn	Note	Approved by:	张勇磊		
BESTAR Holdings Co., Ltd						DRG NO: BS/TES01.1770C1	Page:04 of 09
http://www.be-star.com info@be-star.com							

BLS2035-11-08H7.6W153 LF

3.Drawing

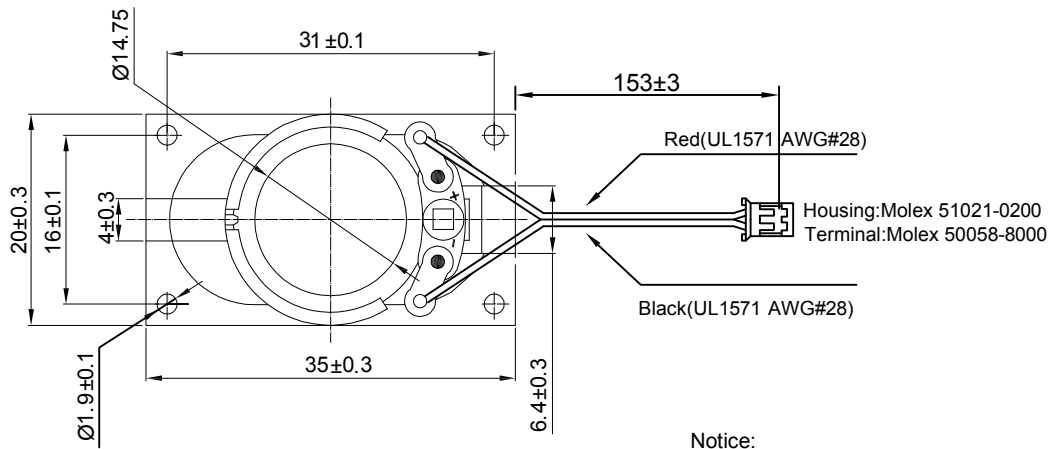
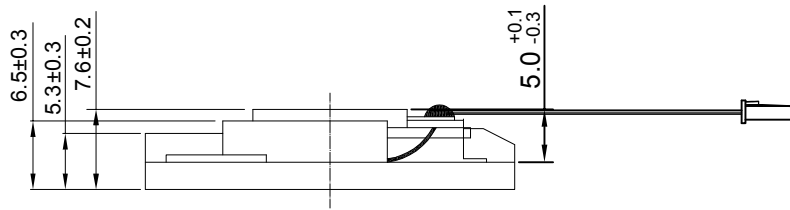

Notice:
Black and red wire glued together

unit:mm
tolerance:±0.2

This print and information there in are proprietary to BESTAR Holdings Co., Ltd. and shall not be used in whole or in part without its written content

				Date:	2019/09/05	BLS2035-11-08H7.6W153 LF
				Drawn by:	杨紫群	
C1	2019/09/05	杨紫群		Checked by:	任江凤	Speaker
Rev.	Date	Drawn	Note	Approved by:	张勇磊	
BESTAR Holdings Co., Ltd						DRG NO: BS/TES01.1770C1
http://www.be-star.com info@be-star.com						Page:05 of 09

BLS2035-11-08H7.6W153 LF

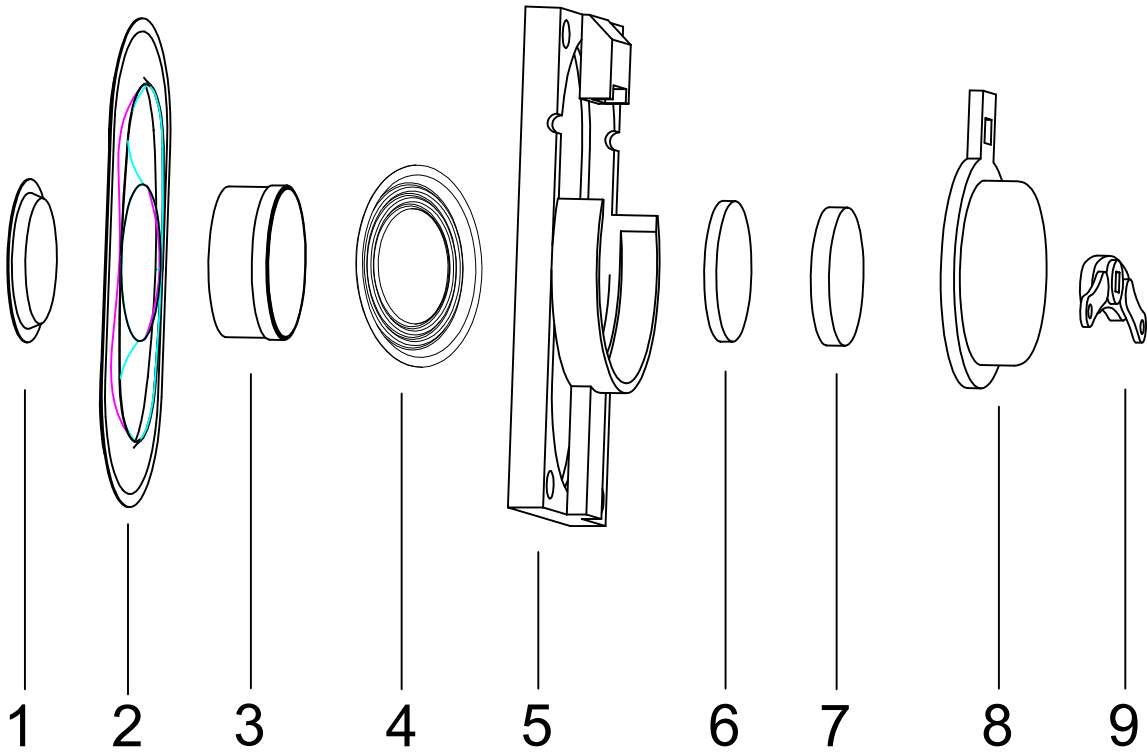

9	Breadboard	Paper+steel
8	Magnet bowl	SPCC
7	Plate	SPCC
6	Magnet steel	NdFeB
5	Frame	ABS777
4	Radiograph	Cloth
3	Voice coil	Kapton+Cu
2	Film	Cloth +Paper
1	Dust shield	Paper
No	Parts Name	Material

				Date:	2019/09/05	BLS2035-11-08H7.6W153 LF	
				Drawn by:	杨紫群		
C1	2019/09/05	杨紫群		Checked by:	任江凤	Speaker	
Rev.	Date	Drawn	Note	Approved by:	张勇磊		
BESTAR Holdings Co., Ltd						DRG NO: BS/TES01.1770C1	Page:06 of 09
http://www.be-star.com info@be-star.com							

This print and information there in are proprietary to BESTAR Holdings Co., Ltd. and shall not be used in whole or in part without its written content

BLS2035-11-08H7.6W153 LF

4. Reliability Test

4.1 High Temperature Load

Temperature +85±2°C
 Duration 96hrs
 Power (Nom) 2.0W(white noise)

4.2 Low Temperature Test

Temperature -40±2°C
 Duration 96hrs

4.3 Damp Heat

Temperature 40±2°C
 Relative Humidity 90%-95%RH
 Duration 24hrs

4.4 Temperature Cycle Test

Cycles 5

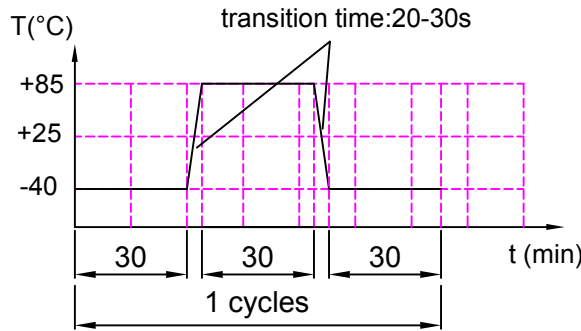

4.5 Drop Test

Height 1.0m
 Drop face thick board (20mm)
 Times 10

4.6 Terminal Strength Test

Capable of withstand 1kg load for 30 seconds without resulting in any damage or rejection

Notice:

1. All these tests above should be measured after leaving normal temperature for 2hrs.
2. Sensitivity difference at 0.8-1.5KHz shall be within ±3dB from initial value after test.

This print and information there in are proprietary to BESTAR Holdings Co., Ltd. and shall not be used in whole or in part without its written content

				Date:	2019/09/05	BLS2035-11-08H7.6W153 LF	
				Drawn by:	杨紫群		
C1	2019/09/05	杨紫群		Checked by:	任江凤	Speaker	
Rev.	Date	Drawn	Note	Approved by:	张勇磊		
BESTAR Holdings Co., Ltd						DRG NO: BS/TES01.1770C1	Page:07 of 09
http://www.be-star.com info@be-star.com							

BLS2035-11-08H7.6W153 LF

5. Packing

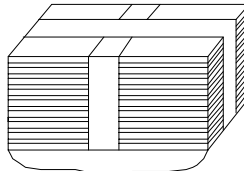
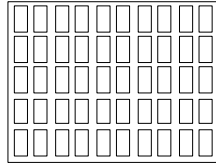

1000pcs

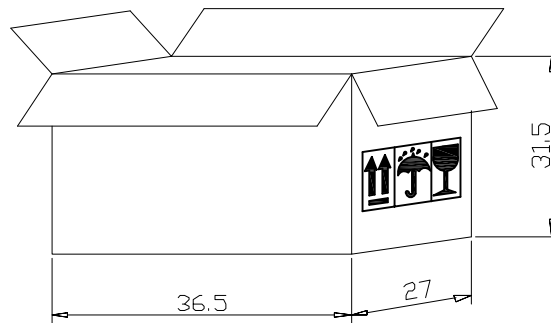

Remark:

50pcs per tray

10 trays for unit, 1 unitsper carton

Total:1000 pcs per box

Size:36.5*27*31.5cm

This print and information there in are proprietary to BESTAR Holdings Co., Ltd. and shall not be used in whole or in part without its written content

				Date:	2019/09/05	BLS2035-11-08H7.6W153 LF	
				Drawn by:	杨紫群		
C1	2019/09/05	杨紫群		Checked by:	任江凤	Speaker	
Rev.	Date	Drawn	Note	Approved by:	张勇磊		
BESTAR Holdings Co., Ltd						DRG NO: BS/TES01.1770C1	Page:08 of 09
http://www.be-star.com info@be-star.com							

BLS2035-11-08H7.6W153 LF

6. History Change Record

version No.	Change Items		Date	Drawn	Approved
	Before	After			
A			2019/09/05	张翔捷	赵 峥
B	Change the magnetic bowl height to 5.0mm		2018/03/28	周嘉明	赵 峥
C1	Change the Operating Temperature to -40~+ 85°C		2019/09/05	杨紫群	张勇磊

This print and information there in are proprietary to BESTAR Holdings Co., Ltd. and shall not be used in whole or in part without its written content

				Date:	2019/09/05	BLS2035-11-08H7.6W153 LF	
				Drawn by:	杨紫群		
C1	2019/09/05	杨紫群		Checked by:	任江凤	Speaker	
Rev.	Date	Drawn	Note	Approved by:	张勇磊		
BESTAR Holdings Co., Ltd http://www.be-star.com info@be-star.com						DRG NO: BS/TES01.1770C1	Page:09 of 09