

Bussmann series NH photovoltaic fuse links



Product description

Eaton's Bussmann series NH size photovoltaic fuse links are specifically designed to protect and isolate photovoltaic array combiners and disconnects.

These fuse links are capable of interrupting low overcurrents associated with faulted PV systems (reverse current, multi-array fault).

Standard features

- Compact design
- Low power loss
- Global accreditations
- Dual indicator feature
- Variation of fixing options
- Compatible with Bussmann series PV NH base range (see data sheet 720136)

Catalogue symbol

- Blade without bolt holes: PV-ratingNH(size)
- Blade with bolt holes PV-ratingNH(size)-B
- Blade with bolt holes and lugs: PV-ratingNH(size)-BL

Fuse size

- NH1, 2 and 3

Technical data

- Volts: 1000 V d.c.
- Amps: 32 to 400 A
- Breaking capacity: 50 kA
- Time constant: 1-3mS
- Class of operation: gPV and UL PV fuse links

Standards/Agency information

- IEC 60269-6
- UL 2579 (file number E335324)
- CSA listed
- RoHS compliant

Microswitches (ordered separately, only for use with bladed version)

- 170H0236
- 170H0238

Fuse holders (ordered separately, only for use with bladed version)

- SD1-D-PV
- SD2-D-PV
- SD3-D-PV

Packaging

- MOQ 3

Table 1. Technical data - Blade without bolt holes

Catalogue number	Fuse size	Current rating (amps)	Energy integrals I^2t (A ² S)		Watts loss (W)	
			Pre-arcing	Total at 1000 V	$0.8I_n$	I_n
PV-32ANH1	NH1	32	80	720	4	8.5
PV-40ANH1	NH1	40	185	1670	5	9
PV-50ANH1	NH1	50	400	3600	6	11
PV-63ANH1	NH1	63	470	4300	6	12
PV-80ANH1	NH1	80	640	5760	8	15.5
PV-100ANH1	NH1	100	1300	11700	8	16.5
PV-110ANH1	NH1	110	2100	18900	9	18.5
PV-125ANH1	NH1	125	2600	23400	9	17.5
PV-160ANH1	NH1	160	5200	46800	14	27.5
PV-175ANH1	NH1	175	8300	74700	15	29
PV-200ANH1	NH1	200	10200	82000	13	25
PV-160ANH2	NH2	160	4600	37000	14	28
PV-200ANH2	NH2	200	9500	76000	16	32
PV-250ANH2	NH2	250	17000	136000	19	38
PV-300ANH3	NH3	300	32000	260000	24	40
PV-315ANH3	NH3	315	32000	260000	26	44
PV-350ANH3	NH3	350	44500	370000	27	45
PV-355ANH3	NH3	355	44500	370000	28	46
PV-400ANH3	NH3	400	67500	550000	30	50

Dimensions - Blade without bolt holes - mm

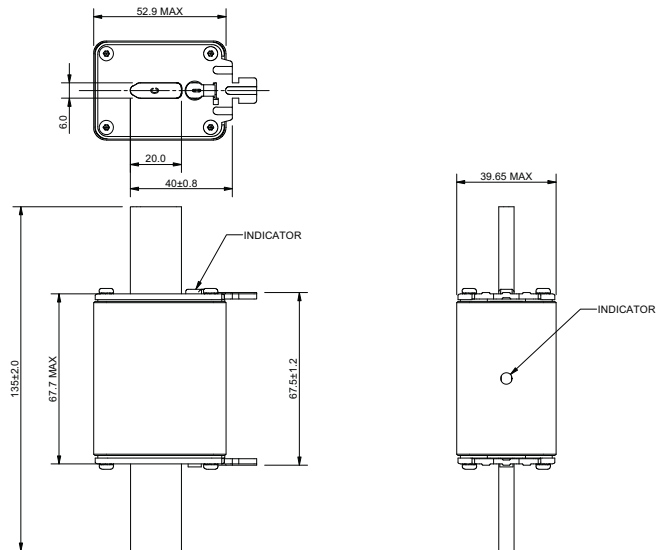

NH size 1

Dimensions - Blade without bolt holes - mm

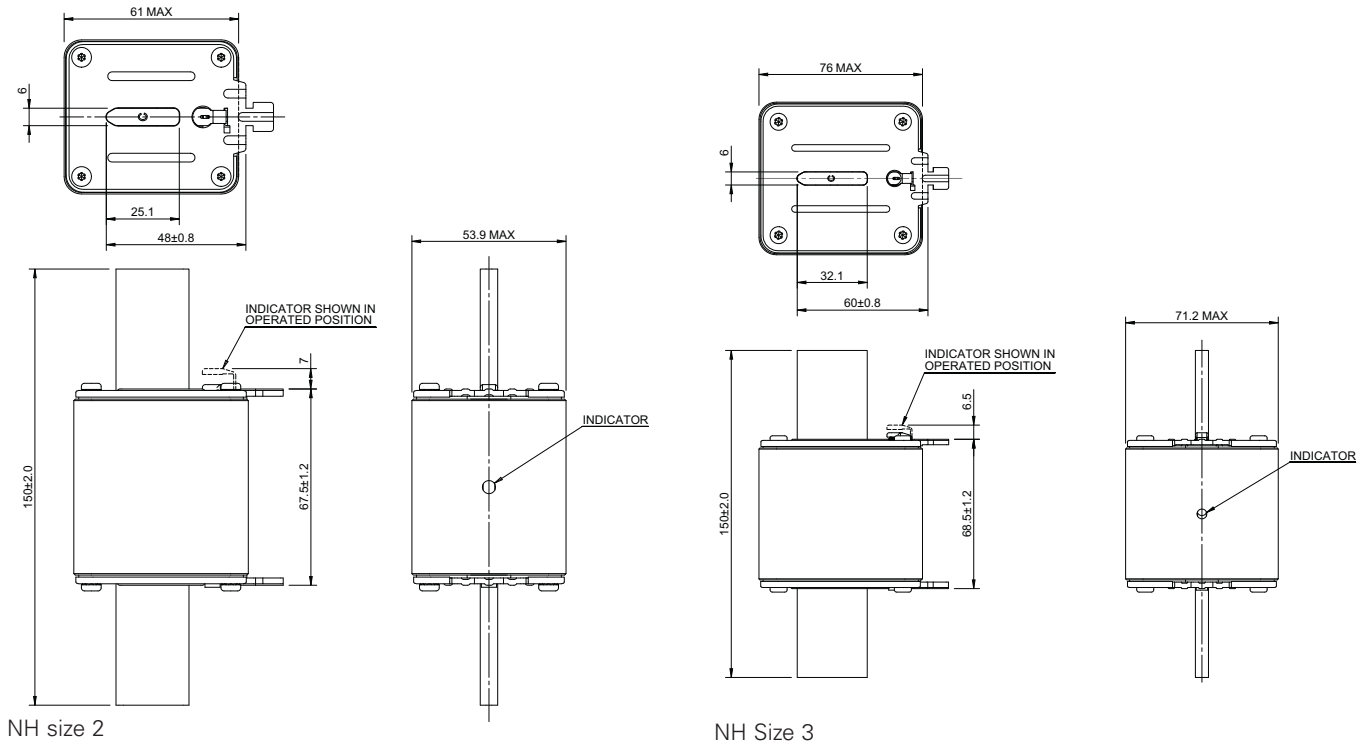

Time current-curve - Blade without bolt holes

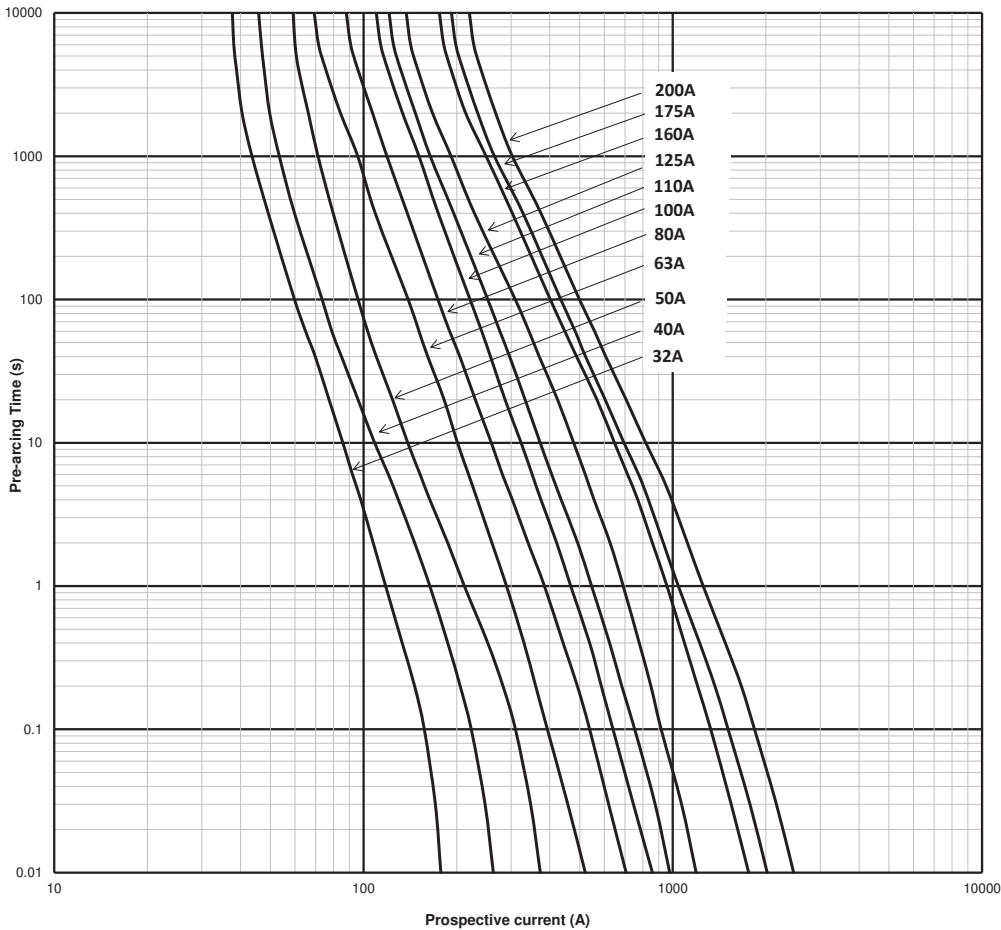

NH Size 1

Time current-curve - Blade without bolt holes

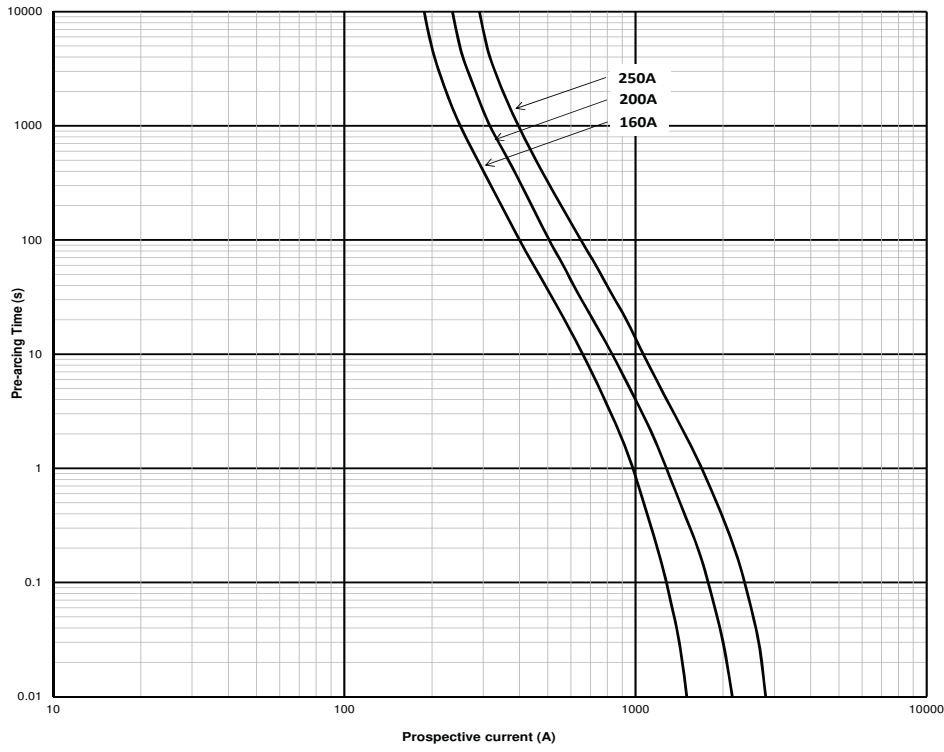

NH size 2

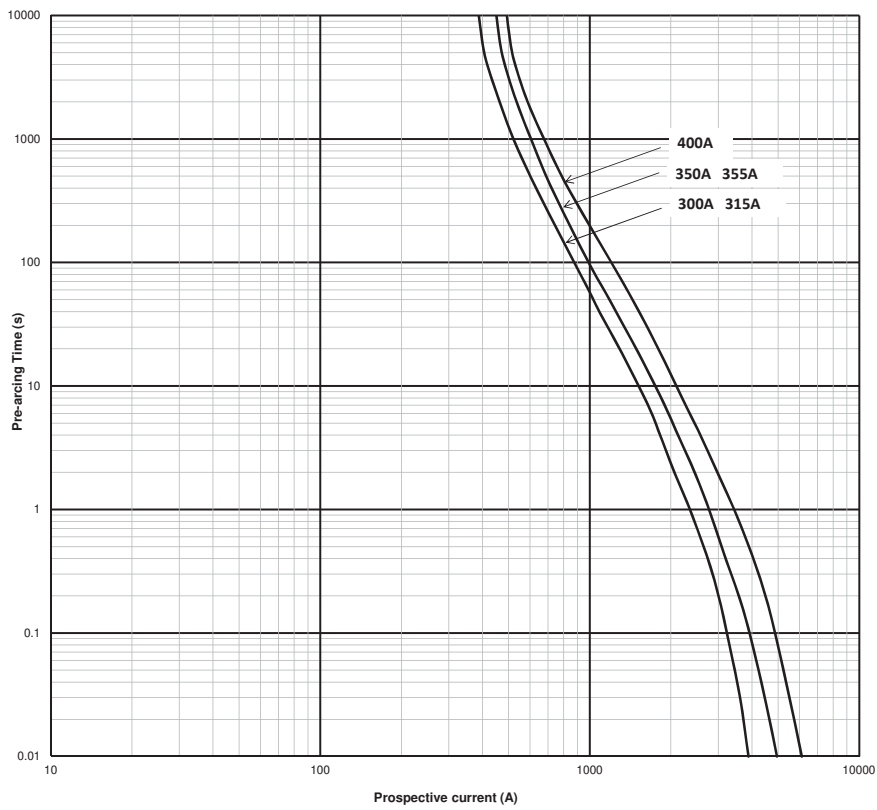

NH size 3

Table 2. Technical data - Blade with bolt holes

Catalogue numbers			Current rating (amps)	Energy integrals I ² t (A ² S)		Watts loss (w)	
With bolt holes	With bolt holes and lugs	Fuse size		Pre-arcing	Total at 1000 V	0.8I _n	I _n
PV-63ANH1-B	PV-63ANH1-BL	NH1	63	470	4300	6	12
PV-80ANH1-B	PV-80ANH1-BL	NH1	80	640	5760	8	15
PV-100ANH1-B	PV-100ANH1-BL	NH1	100	1300	11700	8	16
PV-125ANH1-B	PV-125ANH1-BL	NH1	125	2600	23400	9	17
PV-160ANH1-B	PV-160ANH1-BL	NH1	160	5200	46800	14	27
PV-200ANH1-B	PV-200ANH1-BL	NH1	200	10200	82000	13	25
PV-160ANH2-B	PV-160ANH2-BL	NH2	160	4600	37000	14	28
PV-200ANH2-B	PV-200ANH2-BL	NH2	200	9500	76000	16	32
PV-250ANH2-B	PV-250ANH2-BL	NH2	250	17000	136000	19	38
PV-315ANH3-B	PV-315ANH3-BL	NH3	315	32000	260000	26	44
PV-355ANH3-B	PV-355ANH3-BL	NH3	355	38000	310000	29	48
PV-400ANH3-B	PV-400ANH3-BL	NH3	400	61000	490000	32	50

Dimensions - Blade with bolt holes - mm

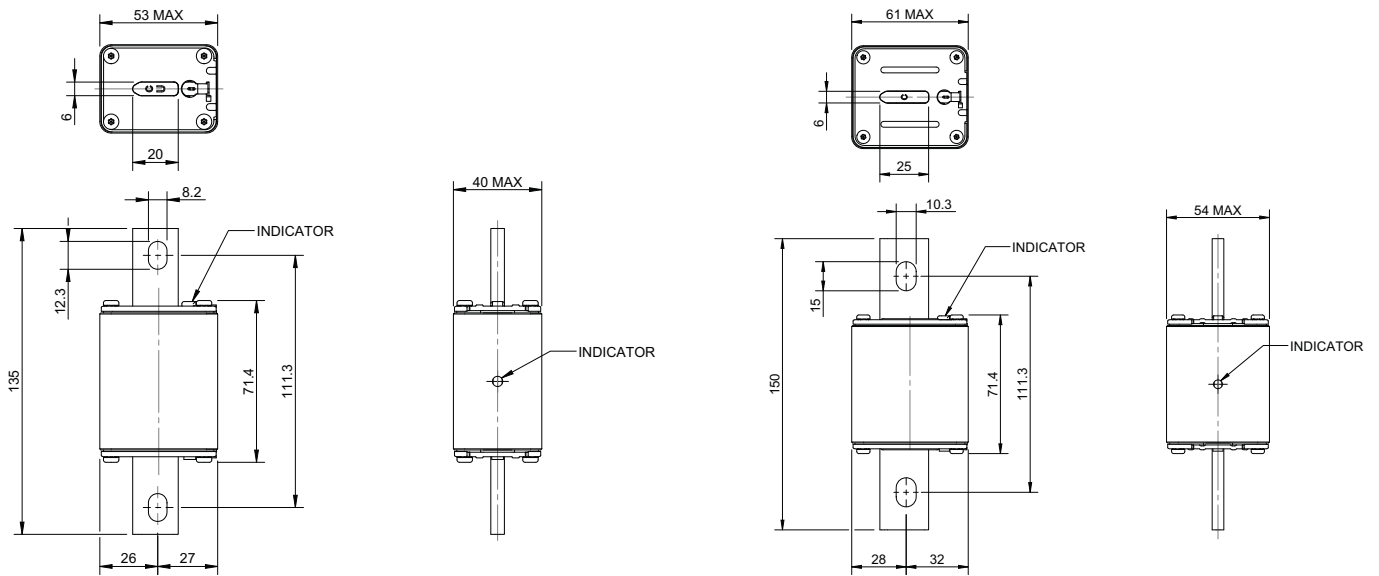

NH size 1

NH size 2

Dimensions - Blade with bolt holes - mm

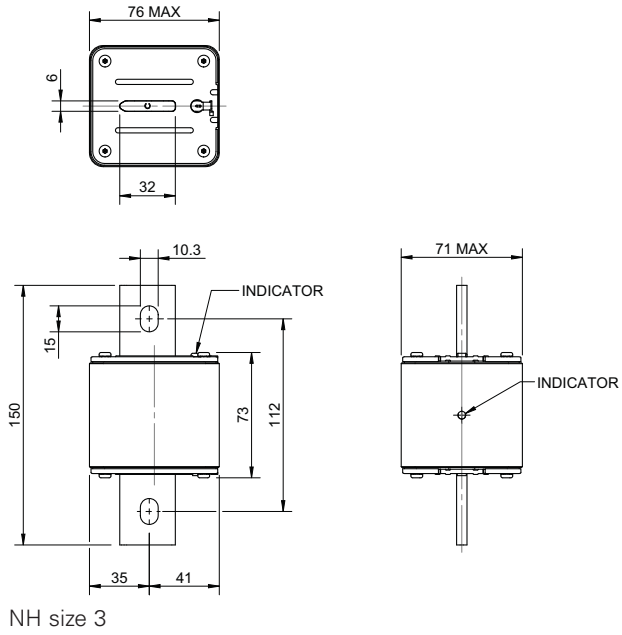

Dimensions - Blade with bolt holes and lugs - mm

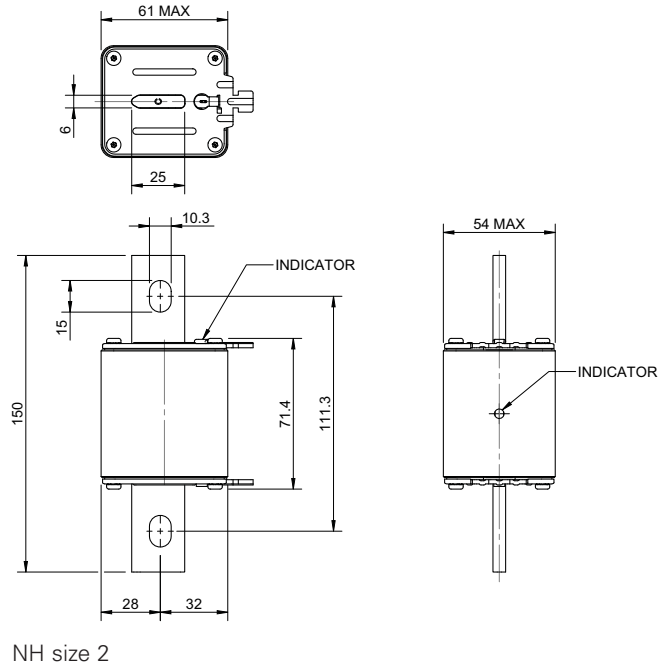

Dimensions - Blade with bolt holes and lugs - mm

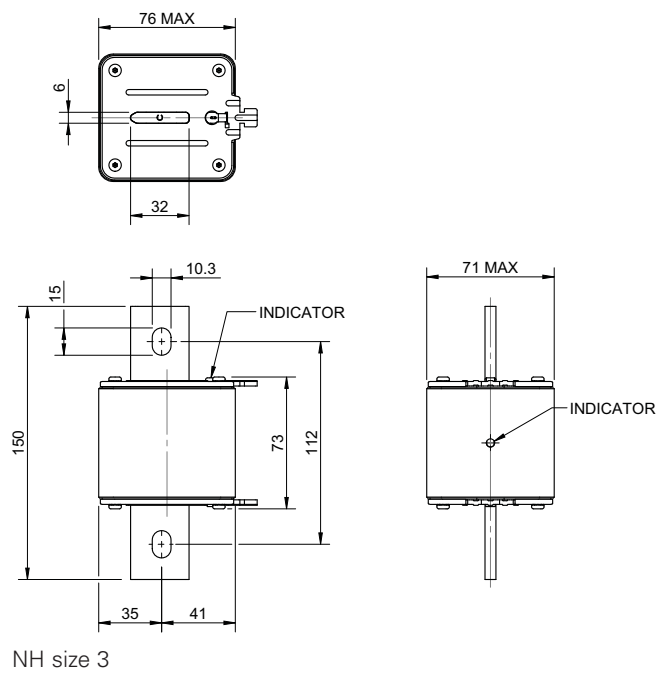
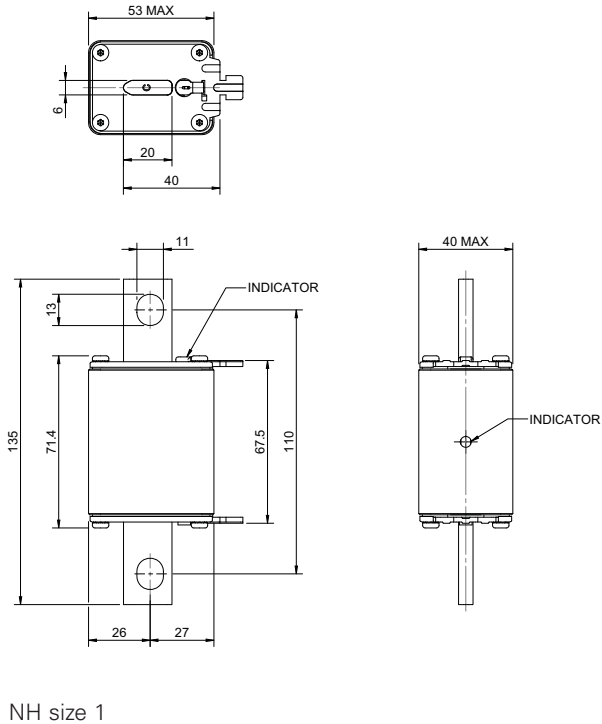

Time current-curve - Blade with bolt holes, with or without lugs

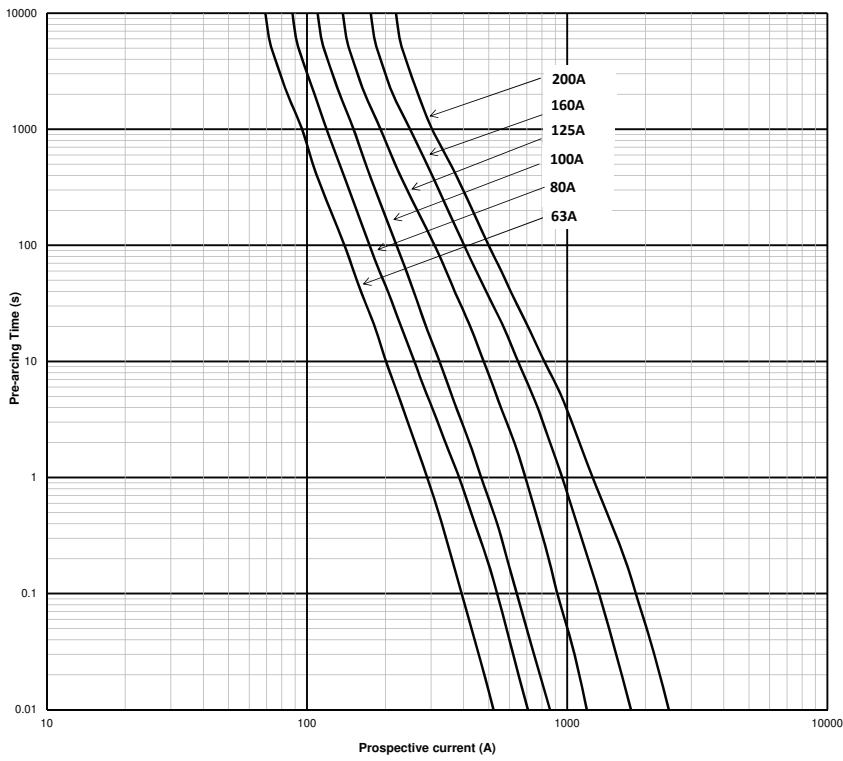

NH size 1

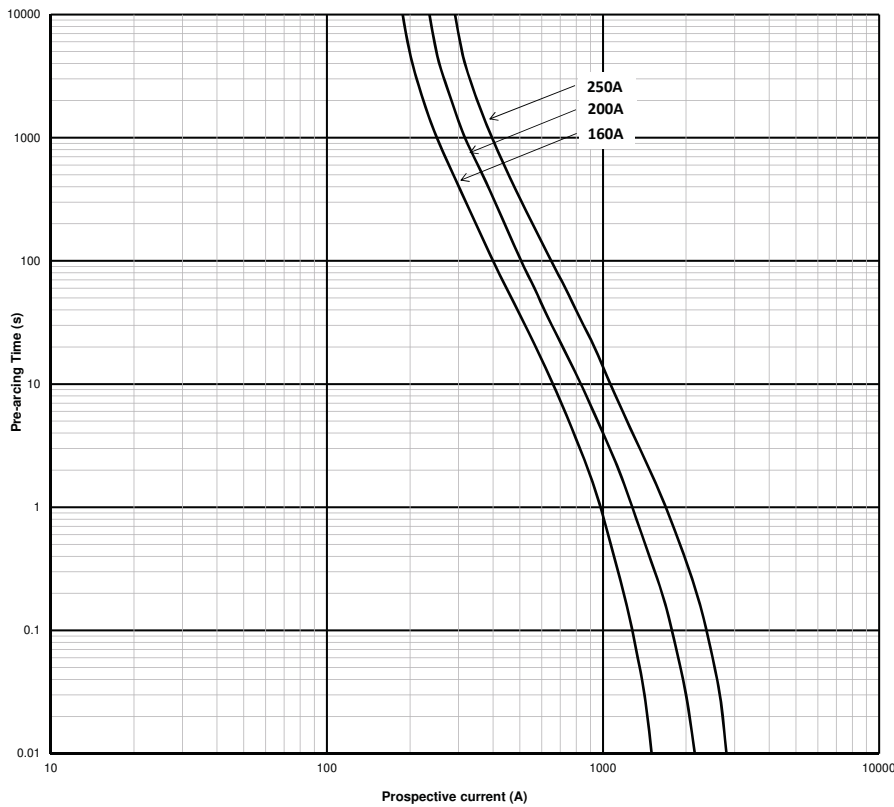

NH size 2

Time current-curve - Blade with bolt holes, with or without lugs

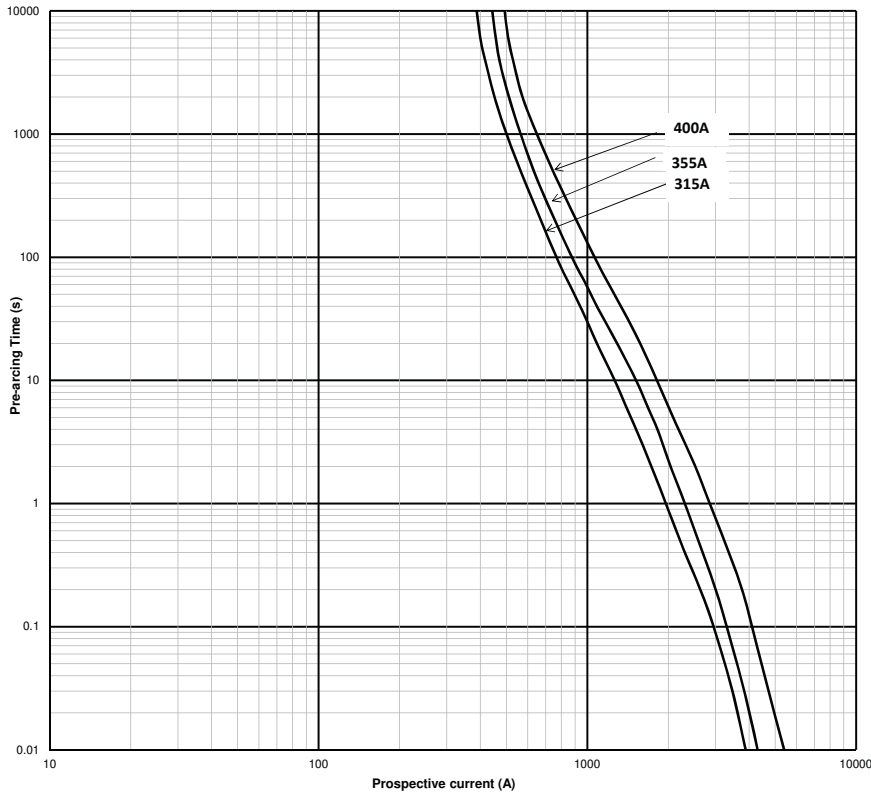

NH size 3

Temperature derating for blades without bolt holes, with bolt holes (with or without lugs)

PV Array fuse link derating with temperature

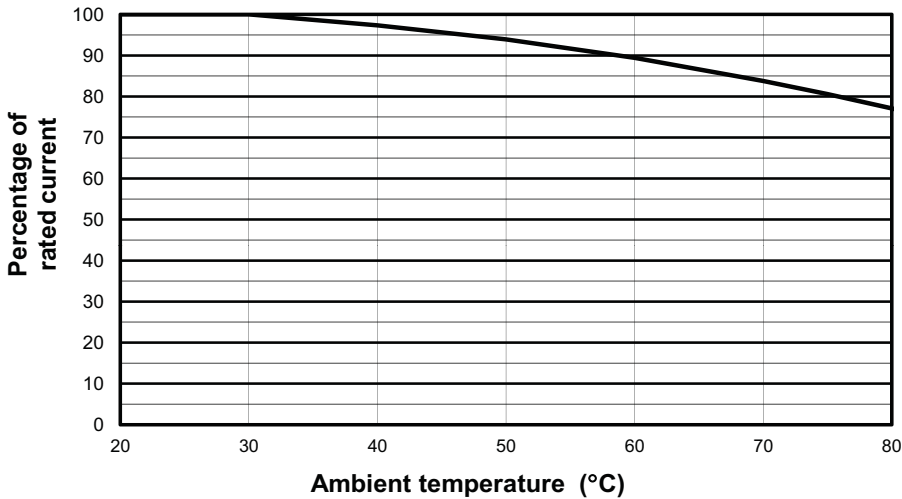

Changes to the products, to the information contained in this document, and to prices are reserved; so are errors and omissions. Only order confirmations and technical documentation by Eaton is binding. Photos and pictures also do not warrant a specific layout or functionality. Their use in whatever form is subject to prior approval by Eaton. The same applies to Trademarks (especially Eaton, Moeller, and Cutler-Hammer). The Terms and Conditions of Eaton apply, as referenced on Eaton Internet pages and Eaton order confirmations.

Eaton
EMEA Headquarters
Route de la Longeraie 7
1110 Morges, Switzerland

Electrical Sector
Eaton
Melton road, Burton-on-the-wolds
LE12 5TH, United Kingdom
Eaton.eu

© 2016 Eaton
All Rights Reserved
Publication No. 720133
January 2016