



ELECTRONICS, INC.  
 44 FARRAND STREET  
 BLOOMFIELD, NJ 07003  
 (973) 748-5089  
<http://www.nteinc.com>

## NTE923 & NTE923D Integrated Circuit Precision Voltage Regulator

**Description:**

The NTE923 and NTE923D are voltage regulators designed primarily for series regulator applications. By themselves, these devices will supply output currents up to 150mA; but, external transistors can be added to provide any desired load current. The circuits feature extremely low standby current drain, and provision is made for either linear or foldback current limiting.

These devices are also useful in a wide range of other applications such as shunt regulators, current regulators, and temperature controllers.

**Features:**

- 150mA Output Current without External Pass Transistor
- Output Currents in Excess of 10A Possible by Adding External Transistors
- Input Voltage: 40V Max
- Output Voltage Adjustable from 2V to 37V
- Can be Used as Either a Linear or a Switching Regulator

**Absolute Maximum Ratings:**

Pulse Voltage from V <sub>+</sub> to V <sub>-</sub> (50ms)	50V
Continuous Voltage from V <sub>+</sub> to V <sub>-</sub>	40V
Input-Output Voltage Differential	40V
Maximum Amplifier Input Voltage	
Either Input	8.5V
Differential	5.0V
Current from V <sub>Z</sub>	25mA
Current from V <sub>REF</sub>	15mA
Internal Power Dissipation	
NTE923	800mW
NTE923D	660mW
Operating Temperature Range	0° to +70°C
Storage Temperature Range	
NTE923	-65° to +150°C
NTE923D	-55° to +150°C
Lead Temperature (During Soldering, 4sec max)	
NTE923	+300°C
NTE923D	+260°C

**Electrical Characteristics:** (Note 1)

Parameter	Test Conditions	Min	Typ	Max	Unit	
Line Regulation	$V_{IN} = 12V$ to $15V$	–	0.01	0.1	% $V_{OUT}$	
		$0^{\circ} \leq T_A \leq +70^{\circ}C$	–	–	0.3	% $V_{OUT}$
	$V_{IN} = 12V$ to $40V$	–	0.1	0.5	% $V_{OUT}$	
Load Regulation	$I_L = 1mA$ to $50mA$	–	0.03	0.2	% $V_{OUT}$	
		$0^{\circ} \leq T_A \leq +70^{\circ}C$	–	–	0.6	% $V_{OUT}$
Ripple Rejection	$f = 50Hz$ to $10kHz$	$C_{REF} = 0$	–	74	–	dB
		$C_{REF} = 5\mu F$	–	86	–	dB
Average Temperature Coefficient of Output Voltage	$0^{\circ} \leq T_A \leq +70^{\circ}C$ , Note 2	–	0.003	0.015	%/ $^{\circ}C$	
Short Circuit Current Limit	$R_{SC} = 10\Omega$ , $V_{OUT} = 0$	–	65	–	mA	
Reference Voltage		6.80	7.15	7.50	V	
Output Noise Voltage	$BW = 100Hz$ to $10kHz$	$C_{REF} = 0$	–	86	–	$\mu V_{rms}$
		$C_{REF} = 5\mu F$	–	2.5	–	$\mu V_{rms}$
Long Term Stability		–	0.05	–	%/1000Hrs	
Standby Current Drain	$I_L = 0$ , $V_{IN} = 30V$	–	1.7	4.0	mA	
Input Voltage Range		9.5	–	40	V	
Output Voltage Range		2.0	–	37	V	
Input–Output Voltage Differential		3.0	–	38	V	
Thermal Resistance, Junction to Ambient		–	105	–	$^{\circ}C/W$	
NTE923	Board mount in still air	–	225	–	$^{\circ}C/W$	
	Board mount in 400LF/Min Air flow	–	90	–	$^{\circ}C/W$	
Thermal Resistance, Junction to Case		–	25	–	$^{\circ}C/W$	

Note 1. Unless otherwise otherwise specified,  $T_A = +25^{\circ}C$ ,  $V_{IN} = V_+ = V_C = 12V$ ,  $V_- = 0$ ,  $V_{OUT} = 5V$ ,  $I_L = 1mA$ ,  $R_{SC} = 0$ ,  $C_I = 100pF$ ,  $C_{REF} = 0$  and divider impedance as seen by error amplifier  $\leq 10k\Omega$ . Line and load regulation specifications are given for the condition of constant chip temperature. Temperature drifts must be taken into account separately for high dissipation conditions.

Note 2. Guaranteed by correlation to other tests.

Note 3. For metal can applications where  $V_Z$  is required, an external 6.2V zener diode should be connected in series with  $V_{OUT}$ .

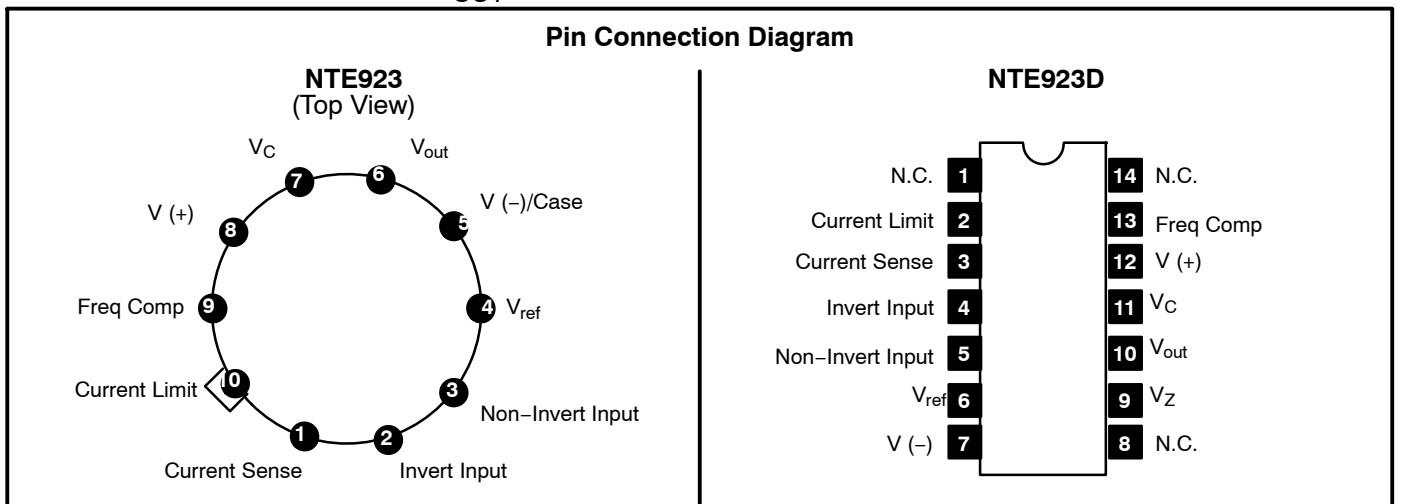

**TABLE 1. Resistor Values (kΩ) for Standard Output Voltage:**

Output Voltage	Applicable Figures	Fixed Output ±5%		Output Adjustable ±10% (Note 5)			Output Voltage	Applicable Figures	Fixed Output ±5%		Output Adjustable ±10% (Note 5)		
	(Note 4)	R1	R2	R1	P1	R2		(Note 4)	R1	R2	R1	P1	R2
+3.0	1, 5, 6, 9, 12 (4)	4.12	3.01	1.8	0.5	1.2	+100	7	3.57	102	2.2	10	91
+3.6	1, 5, 6, 9, 12 (4)	3.57	3.65	1.5	0.5	1.5	+250	7	3.57	255	2.2	10	240
+5.0	1, 5, 6, 9, 12 (4)	2.15	4.99	0.75	0.5	2.2	-6 (Note 6)	3, (10)	3.57	2.43	1.2	0.5	0.75
+6.0	1, 5, 6, 9, 12 (4)	1.15	6.04	0.5	0.5	2.7	-9	3, 10	3.48	5.36	1.2	0.5	2.0
+9.0	2, 4, (5, 6, 9, 12)	1.87	7.15	0.75	1.0	2.7	-12	3, 10	3.57	8.45	1.2	0.5	3.3
+12	2, 4, (5, 6, 9, 12)	4.87	7.15	2.0	1.0	3.0	-15	3, 10	3.65	11.5	1.2	0.5	4.3
+15	2, 4, (5, 6, 9, 12)	7.87	7.15	3.3	1.0	3.0	-28	3, 10	3.57	24.3	1.2	0.5	10
+28	2, 4, (5, 6, 9, 12)	21.0	7.15	5.6	1.0	2.0	-45	8	3.57	41.2	2.2	10	33
+45	7	3.57	48.7	2.2	10	39	-100	8	3.57	97.6	2.2	10	91
+75	7	3.57	78.7	2.2	10	68	-250	8	3.57	249	2.2	10	240

Note 4. Figures in parentheses may be used if R1/R2 divider is placed on opposite input of error amp.

Note 5. Replace R1/R2 in figures with divider shown in Figure .

Note 6. V+ and V<sub>CC</sub> must be connected to a +3V or greater supply.

**TABLE 2. Formulae for Intermediate Output Voltages:**

<b>Outputs from +2 to +7 Volts</b> (Figures 1, 4, 5, 6, 9, 12) $V_{OUT} = \left( V_{REF} \times \frac{R2}{R1 + R2} \right)$	<b>Outputs from +4 to +250 Volts</b> (Figure 7) $V_{OUT} = \left( \frac{V_{REF}}{2} \times \frac{R2 - R1}{R1} \right); R3 = R4$	<b>Current Limiting</b> $I_{LIMIT} = \frac{V_{SENSE}}{R_{SC}}$
<b>Outputs from +7 to +37 Volts</b> (Figures 2, 4, 5, 6, 9, 12) $V_{OUT} = \left( V_{REF} \times \frac{R1 + R2}{R2} \right)$	<b>Outputs from -6 to -250 Volts</b> (Figures 3, 8, 10) $V_{OUT} = \left( \frac{V_{REF}}{2} \times \frac{R1 + R2}{R1} \right); R3 = R4$	<b>Foldback Current Limiting</b> $I_{KNEE} = \left( \frac{V_{OUT} R3}{R_{SC} R4} + \frac{V_{SENSE} (R3 + R4)}{R_{SC} R4} \right)$ $I_{SHORT\ CKT} = \left( \frac{V_{SENSE}}{R_{SC}} \times \frac{R3 + R4}{R4} \right)$

**Typical Applications:** (Pin numbers relative to the plastic package)

**Figure 1. Basic Low Voltage Regulator**  
(V<sub>OUT</sub> = 2 to 7 Volts)

Note:  $R3 = \frac{R1 \times R2}{R1 + R2}$   
for minimum temperature drift.

**Typical Performance**  
 Regulated Output Voltage: 5V  
 Line Regulation (ΔV<sub>IN</sub> = 3V): 0.5mV  
 Load Regulation (ΔI<sub>L</sub> = 50mA): 1.5mV

**Figure 2. Basic High Voltage Regulator**  
(V<sub>OUT</sub> = 27to 37 Volts)

Note:  $R3 = \frac{R1 \times R2}{R1 + R2}$   
for minimum temperature drift.  
R3 may be eliminated for minimum component count.

**Typical Performance**  
 Regulated Output Voltage: 15V  
 Line Regulation (ΔV<sub>IN</sub> = 3V): 1.5mV  
 Load Regulation (ΔI<sub>L</sub> = 50mA): 4.5mV

**Figure 3. Negative Voltage Regulator**

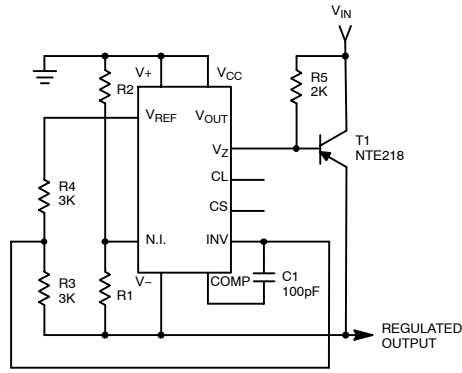

**Typical Performance**  
 Regulated Output Voltage -15V  
 Line Regulation ( $\Delta V_{IN} = 3V$ ) 1mV  
 Load Regulation ( $\Delta I_L = 100mA$ ) 2mV

**Figure 4. Positive Voltage Regulator (External NPN Pass Transistor)**

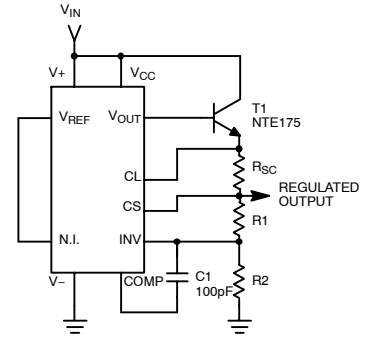

**Typical Performance**  
 Regulated Output Voltage +15V  
 Line Regulation ( $\Delta V_{IN} = 3V$ ) 1.5mV  
 Load Regulation ( $\Delta I_L = 1A$ ) 15mV

**Figure 5. Positive Voltage Regulator (External PNP Pass Transistor)**

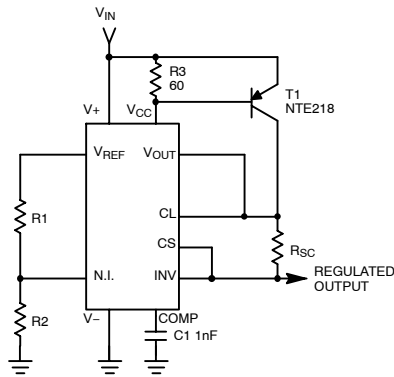

**Typical Performance**  
 Regulated Output Voltage +5V  
 Line Regulation ( $\Delta V_{IN} = 3V$ ) 0.5mV  
 Load Regulation ( $\Delta I_L = 1A$ ) 5mV

**Figure 6. Foldback Current Limiting**

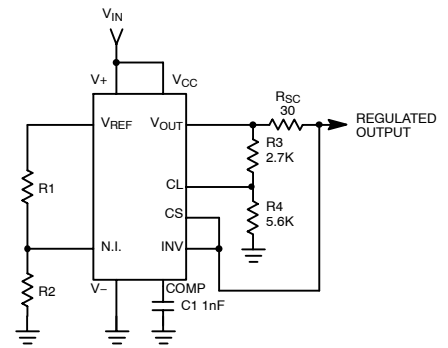

**Typical Performance**  
 Regulated Output Voltage +5V  
 Line Regulation ( $\Delta V_{IN} = 3V$ ) 0.5mV  
 Load Regulation ( $\Delta I_L = 10mA$ ) 1mV  
 Short Circuit Current 20mA

**Figure 7. Positive Floating Regulator**

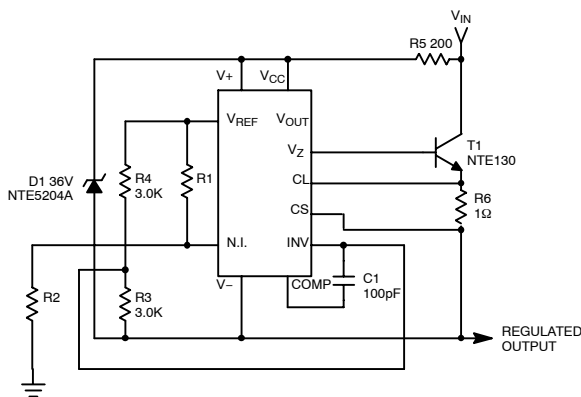

**Typical Performance**  
 Regulated Output Voltage +50V  
 Line Regulation ( $\Delta V_{IN} = 20V$ ) 30mV  
 Load Regulation ( $\Delta I_L = 100mA$ ) 20mV

**Figure 8. Negative Floating Regulator**

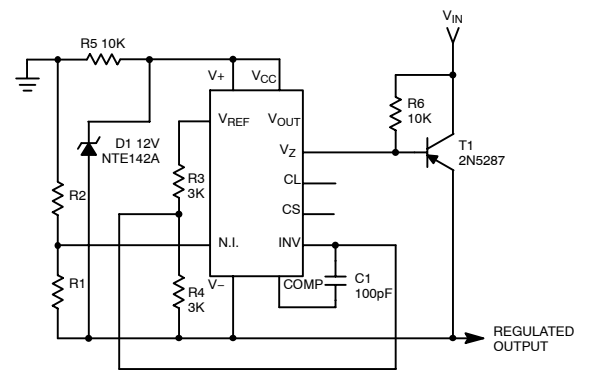

**Typical Performance**  
 Regulated Output Voltage -100V  
 Line Regulation ( $\Delta V_{IN} = 20V$ ) 30mV  
 Load Regulation ( $\Delta I_L = 100mA$ ) 20mV

**Figure 9. Positive Switching Regulator**

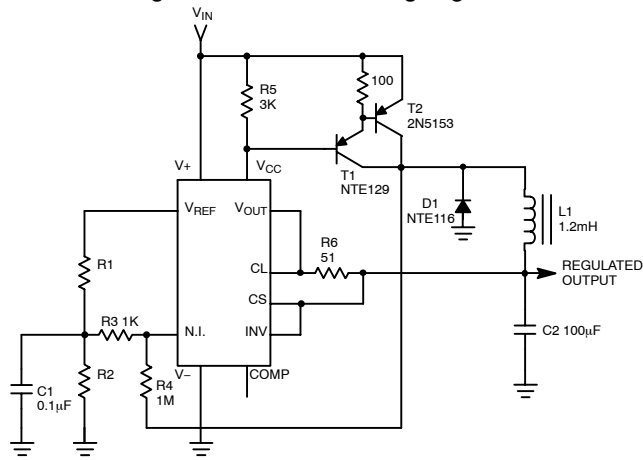

**Typical Performance**  
 Regulated Output Voltage +5V  
 Line Regulation ( $\Delta V_{IN} = 30V$ ) 10mV  
 Load Regulation ( $\Delta I_L = 2A$ ) 80mV

**Figure 10. Negative Switching Regulator**

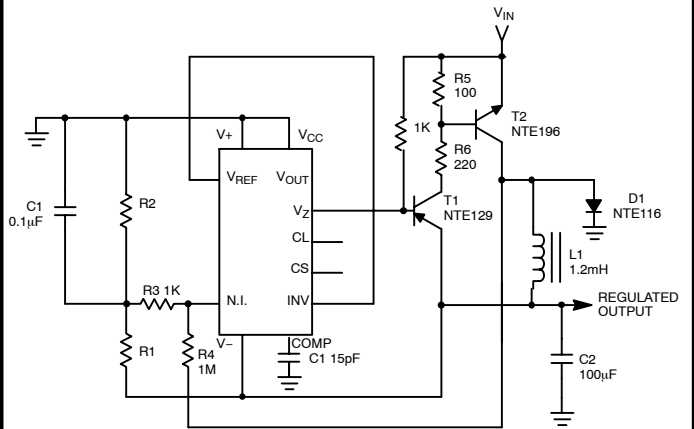

**Typical Performance**  
 Regulated Output Voltage -15V  
 Line Regulation ( $\Delta V_{IN} = 20V$ ) 8mV  
 Load Regulation ( $\Delta I_L = 2A$ ) 6mV

**Figure 11. Remote Shutdown Regulator with Current Limiting**

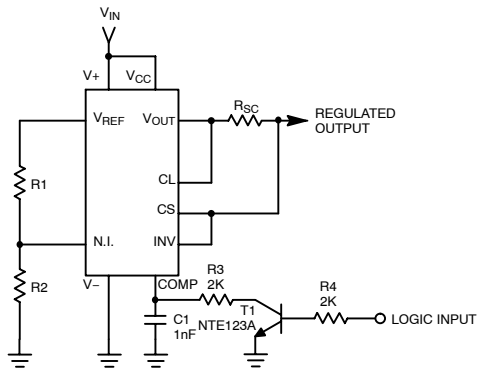

**Typical Performance**  
 Regulated Output Voltage +5V  
 Line Regulation ( $\Delta V_{IN} = 3V$ ) 0.5mV  
 Load Regulation ( $\Delta I_L = 50mA$ ) 1.5mV

**Figure 12. Shunt Regulator**

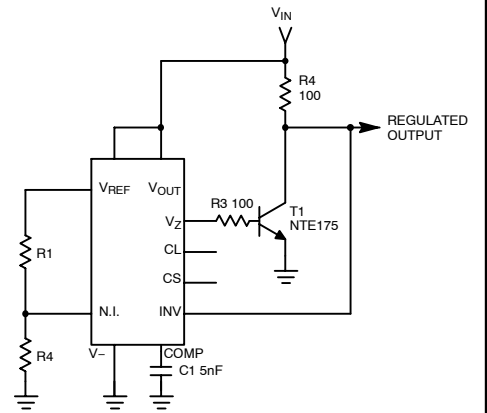

**Typical Performance**  
 Regulated Output Voltage +5V  
 Line Regulation ( $\Delta V_{IN} = 10V$ ) 0.5mV  
 Load Regulation ( $\Delta I_L = 100mA$ ) 1.5mV

**Figure 13. Output Voltage Adjust (Note 6)**

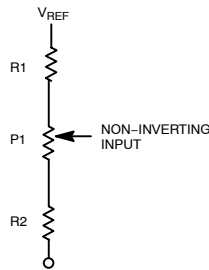

**NTE923**

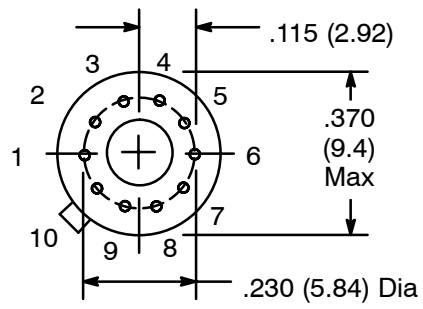
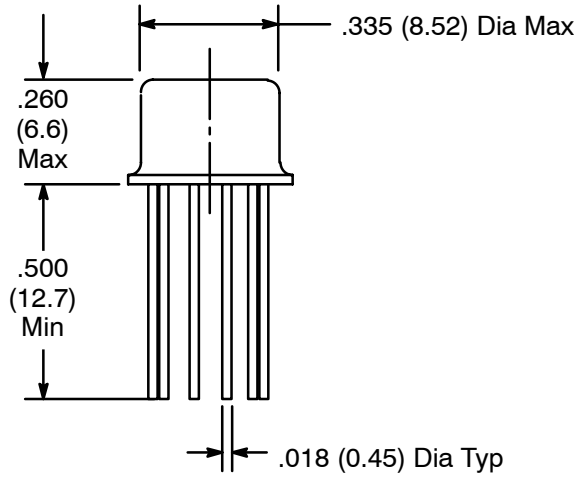

**NTE923D**

