

SUMMARY

Wires

Low voltage 4



Image is for illustrative purpose only

| | |
|------------------|--------------------------------|
| Series | MM |
| Termination type | Male crimp |
| IP rating | 68 mated (mating interface) |
| AWG wire size | 32.00 - 28.00 |
| Cable Ø | 2.80 - 5.60 mm |
| Status | active |
| Matching parts | EGN.MM.304.XLM |

Download

[Request a quote](#)

[Catalog](#)

[See video assembly instructions](#)

TECHNICAL DETAILS

Mechanics

| | |
|-------------------|---|
| Shell Style/Model | FG*: Straight plug with arctic grip and mold stop |
| Keying | 3 keys (beta=165, gamma=30, plug: male contacts, receptacle: female contacts) |
| Housing Material | Aluminium (nickel plated [SAE AMS QQ N 290], anthracite color) shell and nut, other pieces bronze/brass |
| Weight | 4.50 g |

Performance

| | |
|---------------|------------------------|
| Configuration | MM.304 : 4 Low Voltage |
| Insulator | L: PEEK |
| Rated Current | 2 Amps |

Specifications

Contact Type: Crimp
Contact Retention: 12 N
Contact Dia.: 0.5 mm (0.02in)
Bucket Dia.: 0.45 mm (0.018in)
Min. Conductor: 0.035 mm² (AWG 32)
Max. Conductor: 0.09 mm² (AWG 28)
R (max): 8.7 mOhm

LEMO products and services are provided "as is". LEMO makes no warranties or representations with regard to LEMO product & services or use of them, express, implied or statutory, including for accuracy, completeness, or security. The user is fully responsible for his products and applications using LEMO components.

Others

Endurance (Shell): 3000 mating cycles

Temp (min / max): -20°C / +200°C

Humidity (max): 21 days at 95%

Gunfire vibration: 25 Hz - 2000 Hz, 3 axis (Apache helicopter)

Vibration-Sine: 30 g, 3 axes, 12 hr [10 Hz - 2000 Hz]

Vibration-Random: 37.8 g rms - 3 axes, 4 hr amb [50 Hz - 2000 Hz]

Shock Resistance: 300 g [3 ms]

Lighting strike EIA 364-75: 10K amps - 6 times

Thermal shock: 5 cycles: -65°C to +150°C

EMI Shielding EIA 364-66A: >= 80 dB (1 GHz), >=70 dB (3 GHz), >= 58 dB (6 GHz), >= 40 dB (10 GHz)

Salt Spray Corrosion: max. 48 hr

DRAWINGS

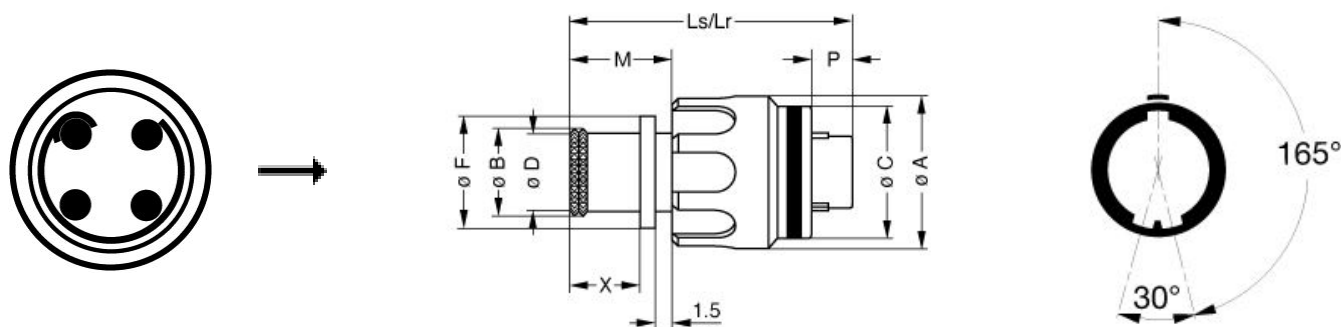

Dimensions

| | A | B | C | D | F | Lr | Ls | M | P | X |
|-----|------|------|------|------|------|------|------|------|------|------|
| mm. | 12 | 6.4 | 10.7 | 5.6 | 7.8 | 24.3 | 24.3 | 8.8 | 5.5 | 5.8 |
| in. | 0,47 | 0,25 | 0,42 | 0,22 | 0,31 | 0,96 | 0,96 | 0,35 | 0,22 | 0,23 |

RECOMMENDED BY LEMO

Tools

Crimp Tool: [DPC.91.701.V](#)

LEMO products and services are provided "as is". LEMO makes no warranties or representations with regard to LEMO product & services or use of them, express, implied or statutory, including for accuracy, completeness, or security. The user is fully responsible for his products and applications using LEMO components.

Crimp settings: AWG/Selector = 28-30-32/4-3-3
Positionner: [DCE.91.050.0VC](#)
Extractor: [DCC.05.02B.LAG](#)
Replacement contact: FGG.00.554.ZZC

LEMO products and services are provided "as is". LEMO makes no warranties or representations with regard to LEMO product & services or use of them, express, implied or statutory, including for accuracy, completeness, or security. The user is fully responsible for his products and applications using LEMO components.