

- 1 MOLDED PARTS: POLYESTER, UL RATED 94V-0, BLACK. CONTACTS: BERYLLIUM COPPER.
- 2 2.54 μm [.000100] MIN TIN-LEAD ON TERMINATION END, 0.76 μm [.000030] MIN GOLD ON CONTACT AREA, ALL OVER 1.27 μm [.000050] MIN NICKEL.
- 3 POSITION TOLERANCE APPLIES 0.76 [.030] ABOVE DATUM V.
- 4 POSITION NUMBER 1 INDICATOR.
- 5 ELECTRICAL ENGAGEMENT ZONE.
- 6 RECOMMENDED 28 AWG RIBBON CABLE, 0.61 - 0.97 [.024 - .038] THICK PVC, 1.0000 [.03937] PITCH.
- 7 AMP LOGO ORIENTATION IS OPTIONAL.
- 8 RECESS ON EACH END, OPPOSITE CORNER.
- 9 0.13 μm [.000005] MIN GOLD ON TERMINATION END, 0.76 μm [.000030] MIN GOLD ON CONTACT AREA, ALL OVER 1.27 μm [.000050] MIN NICKEL.
- 10 MOLD GATE PROJECTION ON EITHER END OF COVER TO BE EXCLUDED FROM DIMENSION 'B' MEASUREMENT.

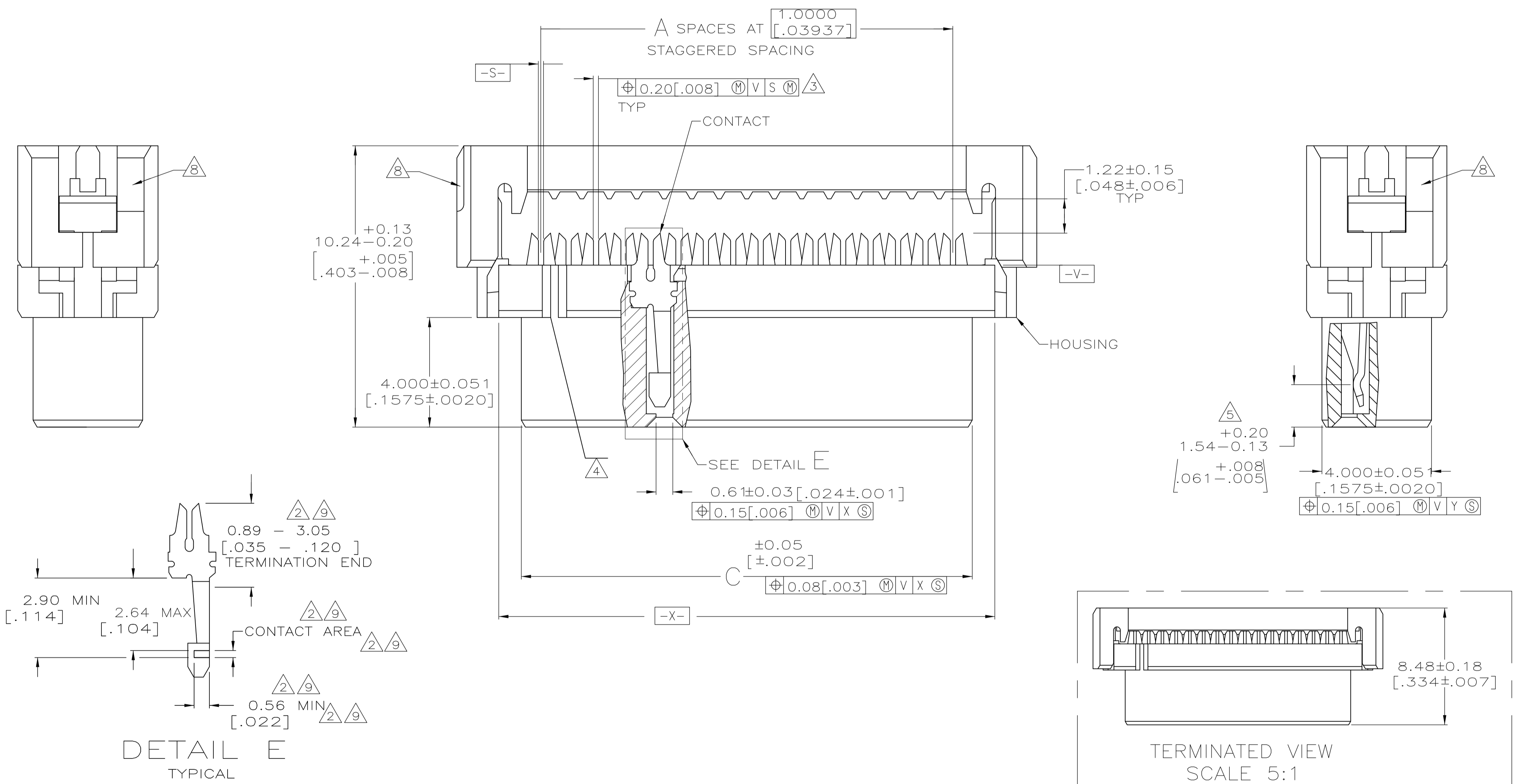

REV	DESCRIPTION	DATE	DWN	APVD
25		26		
23		24		
15		16		
7		8		
49		50		
43		44		
39		40		
33		34		
19		20		
13		14		
9		10		
7		8		
21		22		
67		68		
63		64		
59		60		
49		50		
43		44		
39		40		
33		34		
29		30		
25		26		
23		24		
19		20		
15		16		
13		14		
9		10		

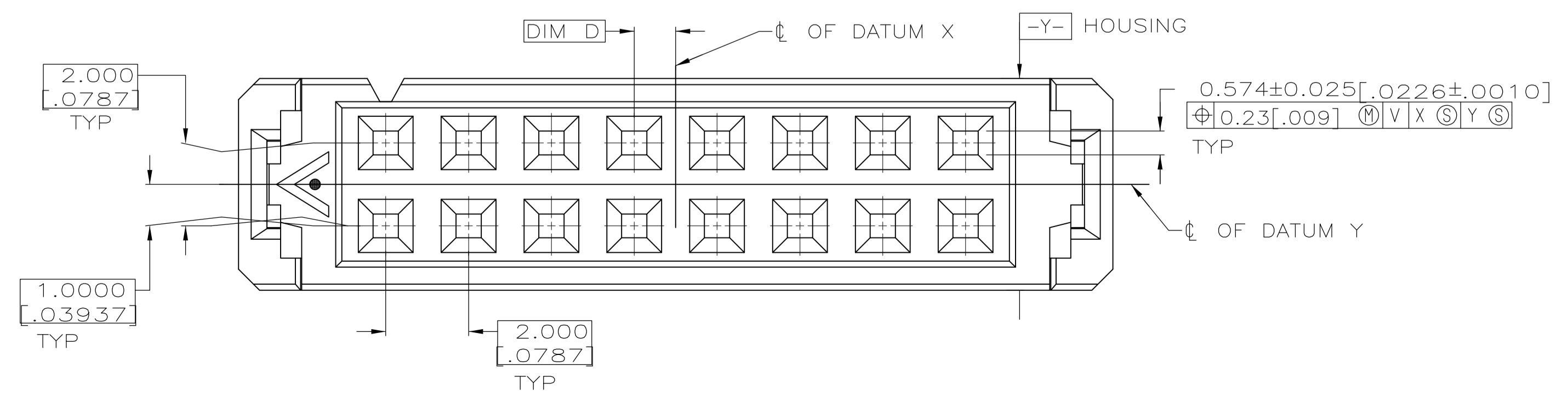

THIS DRAWING IS A CONTROLLED DOCUMENT. DIMENSIONS: mm [INCHES]. TOLERANCES UNLESS OTHERWISE SPECIFIED: 0 PLC ± .005, 1 PLC ± .005, 2 PLC ± .005, 3 PLC ± .005, 4 PLC ± .005. MATERIAL: POLYESTER. FINISH: GOLD/NICKEL/TIN-LEAD. THIS DRAWING IS A CONTROLLED DOCUMENT. DIMENSIONS: mm [INCHES]. TOLERANCES UNLESS OTHERWISE SPECIFIED: 0 PLC ± .005, 1 PLC ± .005, 2 PLC ± .005, 3 PLC ± .005, 4 PLC ± .005. MATERIAL: POLYESTER. FINISH: GOLD/NICKEL/TIN-LEAD.

REVISIONS	DATE	DWN	APVD
25	26		
23	24		
15	16		
7	8		
49	50		
43	44		
39	40		
33	34		
19	20		
13	14		
9	10		

CONTACT FINISH: D, C, B, A. NO OF POSN: 25. PART NO: 111626-7.

STE TE Connectivity

RECEPTACLE ASSY, 2mm CL, AMP-LATCH

SIZE: A1. CAGE CODE: 00779. DRAWING NO: 111626. RESTRICTED TO: CUSTOMER DRAWING. SCALE: 10:1. SHEET: 1 OF 1. REV: M2.