

# OPTION A

- NOTES:
- MATERIAL:  
HOUSING: POLYESTER(PBT), GLASS FILLED, UL94 V-0,  
COLOR: BLACK  
TERMINAL: PHOSPHOR BRONZE
  - FINISH:  
15 GOLD: 0.38 MICROMETERS/15 MICROINCHES MINIMUM GOLD IN  
1.91 MICROMETERS/75 MICROINCHES MINIMUM TIN  
OVER NICKEL UNDERPLATE OVERALL
  - TO BE USED WITH 26 AWG STRANDED WIRE WITH (1.35)/.053  
DIAMETER MAXIMUM INSULATION
  - SEE TABLE FOR AVAILABLE CIRCUIT SIZES
  - STANDARD PACKAGING PER PK-70873-0001. OPTIONAL PACKAGING  
MAY BE AVAILABLE, REQUEST DRAWING PK-70400
  - PARTS STACKABLE END TO END ON (2.54)/.100 CENTERS
  - PRODUCT SPECIFICATION: PS-70400
  - SEE DRAWING SDA-70400-\*\*\*\* (SHEET 3) FOR OPTIONAL  
HOUSING DETAILS
  - 4 CIRCUIT SHOWN
  - TO MATE WITH MOLEX 2.54/.100 CENTERLINE HEADERS
  - 2 CIRCUIT ASSEMBLIES SUPPLIED AS GROUPED PAIRS

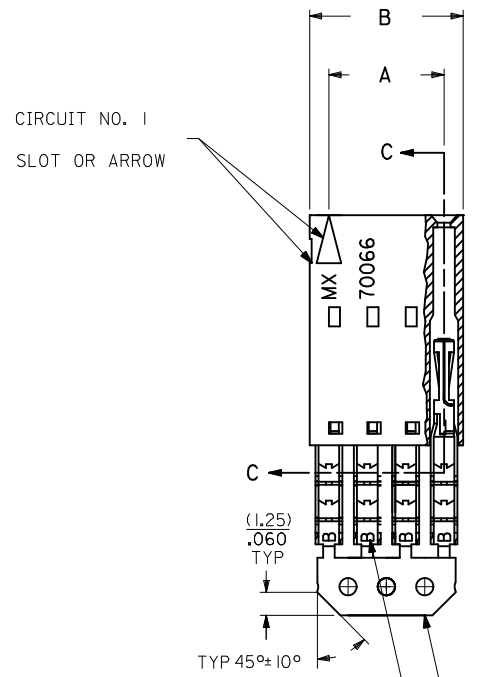

## SECTION C-C

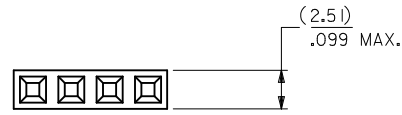
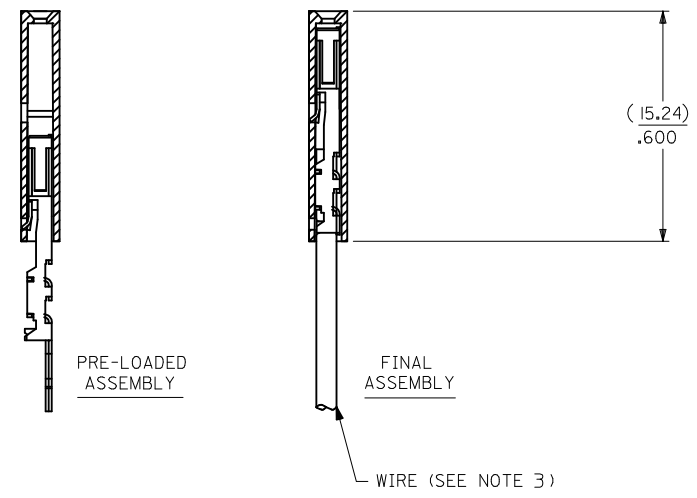

CKT. SIZE	A	B	EDP. NO.
2	( 2.54 ) .100	( 5.05 ) .199	14-56-2023
3	( 5.08 ) .200	( 7.59 ) .299	14-56-2033
4	( 7.62 ) .300	( 10.13 ) .399	14-56-2043
5	( 10.16 ) .400	( 12.67 ) .499	14-56-2053
6	( 12.70 ) .500	( 15.21 ) .599	14-56-2063
7	( 15.24 ) .600	( 17.75 ) .699	14-56-2073
8	( 17.78 ) .700	( 20.29 ) .799	14-56-2083
9	( 20.32 ) .800	( 22.83 ) .899	14-56-2093
10	( 22.86 ) .900	( 25.37 ) .999	14-56-2103
11	( 25.40 ) 1.000	( 27.91 ) 1.099	14-56-2113
12	( 27.94 ) 1.100	( 30.45 ) 1.199	14-56-2123
13	( 30.48 ) 1.200	( 32.99 ) 1.299	14-56-2133
14	( 33.02 ) 1.300	( 35.53 ) 1.399	14-56-2143
15	( 35.56 ) 1.400	( 38.07 ) 1.499	14-56-2153
16	( 38.01 ) 1.500	( 40.61 ) 1.599	14-56-2163
17	( 40.64 ) 1.600	( 43.15 ) 1.699	14-56-2173
18	( 43.18 ) 1.700	( 45.69 ) 1.799	14-56-2183
19	( 45.72 ) 1.800	( 48.23 ) 1.899	14-56-2193
20	( 48.26 ) 1.900	( 50.77 ) 1.999	14-56-2203
21	( 50.80 ) 2.000	( 53.31 ) 2.099	14-56-2213
22	( 53.34 ) 2.100	( 55.85 ) 2.199	14-56-2223
23	( 55.88 ) 2.200	( 58.39 ) 2.299	14-56-2233
24	( 58.42 ) 2.300	( 60.93 ) 2.399	14-56-2243
25	( 60.96 ) 2.400	( 63.47 ) 2.499	14-56-2253

I.D. SLOT CODE TO WIRE GAUGE CHART	
I.D. SLOT CODE	WIRE GAUGE
B	26 AWG.

PLATING CODE (STRIPE ON CARRIER STRIP)	
PLATING	COLOR
15 GOLD	YELLOW

REMOVE ENG NO. EC NO: UCP2011-110 DRW:MSI BARRA 2010/10/19 CHKD:J MORGAN 2010/10/19 APPR:SMILLER 2010/11/24	QUALITY SYMBOLS ∇=0 ∇=0 ∇=0	GENERAL TOLERANCES (UNLESS SPECIFIED) mm INCH 4 PLACES ± --- ± --- 3 PLACES ± --- ± .010 2 PLACES ± 0.25 ± .014 1 PLACE ± 0.35 ± --- ANGULAR ± 1/2°	DIMENSION STYLE MM/IN DRAWN BY DATE MSI BARRA 2010/10/19 CHECKED BY DATE WAZ 1984/10/09 APPROVED BY DATE SMILLER 2010/11/24	SCALE DESIGN UNITS INCH TITLE ASSEMBLY, SL CONNECTOR SINGLE ROW 2.54/.100 GRID	THIRD ANGLE PROJECTION
		DRAFT WHERE APPLICABLE MUST REMAIN WITHIN DIMENSIONS	MATERIAL NO. SEE TABLE	DOCUMENT NO. SDA-70400-0701-0724	SHEET NO. 1 OF 1
		THIS DRAWING CONTAINS INFORMATION THAT IS PROPRIETARY TO MOLEX INCORPORATED AND SHOULD NOT BE USED WITHOUT WRITTEN PERMISSION			
		MOLEX INCORPORATED			