

LTC4425EDD: Linear Supercap Charger With Current-Limited Ideal Diode And V/I Monitor

DESCRIPTION

Demonstration Circuit DC1589A is a Linear Supercap Charger with Current-Limited Ideal Diode and V/I Monitor, featuring the LTC[®]4425.

PERFORMANCE SUMMARY Specifications are at T_a = 25°C

SYMBOL	PARAMETER	CONDITIONS	MIN	TYP	MAX	UNITS
V _{in}	Input Voltage Range		2.7		5.5	V
I _{charge}	Supercap Charge current				2	A
V _{OUT}	Supercap Stack Output Voltage		1.2		5.4	V
V(MID)	Supercap Midpoint Voltage		0.6		2.7	V

QUICK START PROCEDURE

Refer to Figure 1 for the proper measurement equipment setup and jumper settings and follow the procedure below.

NOTE. When measuring the input or output voltage ripple, care must be taken to avoid a long ground lead on the oscilloscope probe. Measure the input or output voltage ripple by touching the probe tip directly across the VBUS or VOUT(x) and GND terminals. See Figure 2 for proper scope probe technique.

1. Set b[2-0] jumpers (JP3, JP4, JP5) to "1". Set MODE (JP6) to "LDO". Set LD1 to 0A, and PS1 to 5V. Observe VOUT (VM3) = 3.3V, I(VIN) (AM1) = 2A, and V(PROG) (VM2) = 1V. Note: The supercapacitor COUT1 will charge in approximately 0.5 seconds, so please observe these signals within a few seconds of setting PS1 to 5V.
2. Set PS1 to 0V. Observe D1 (PFO) should be lit due to input 'power failure'
3. Set LD1 to 1A. Observe VOUT. VOUT should decrease to 0V, in about 1 second.

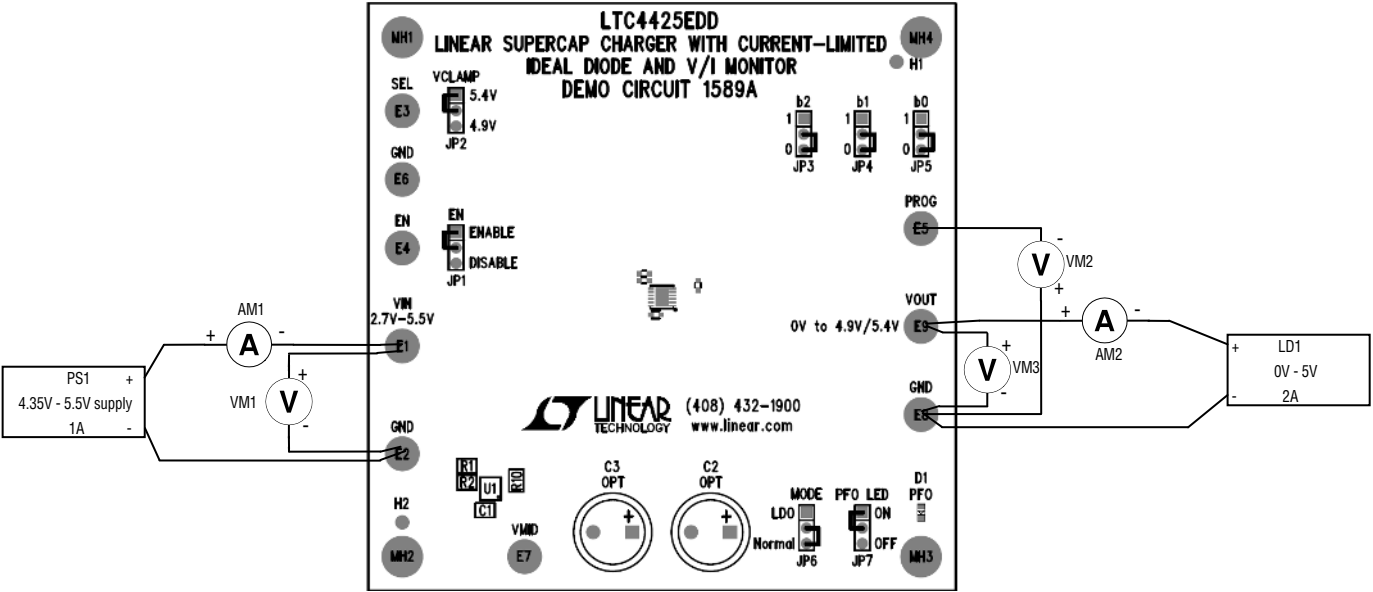

Note: All connections from equipment should be Kelvin connected directly to the board pins which they are connected on this diagram and any input or output leads should be twisted pair.

Figure 1. Proper Measurement Equipment Setup for DC1550A

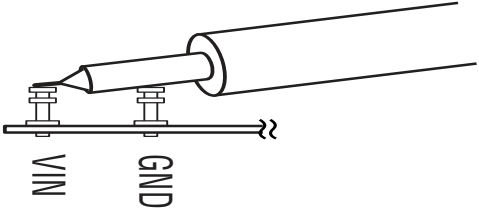

Figure 2. Measuring Input or Output Ripple

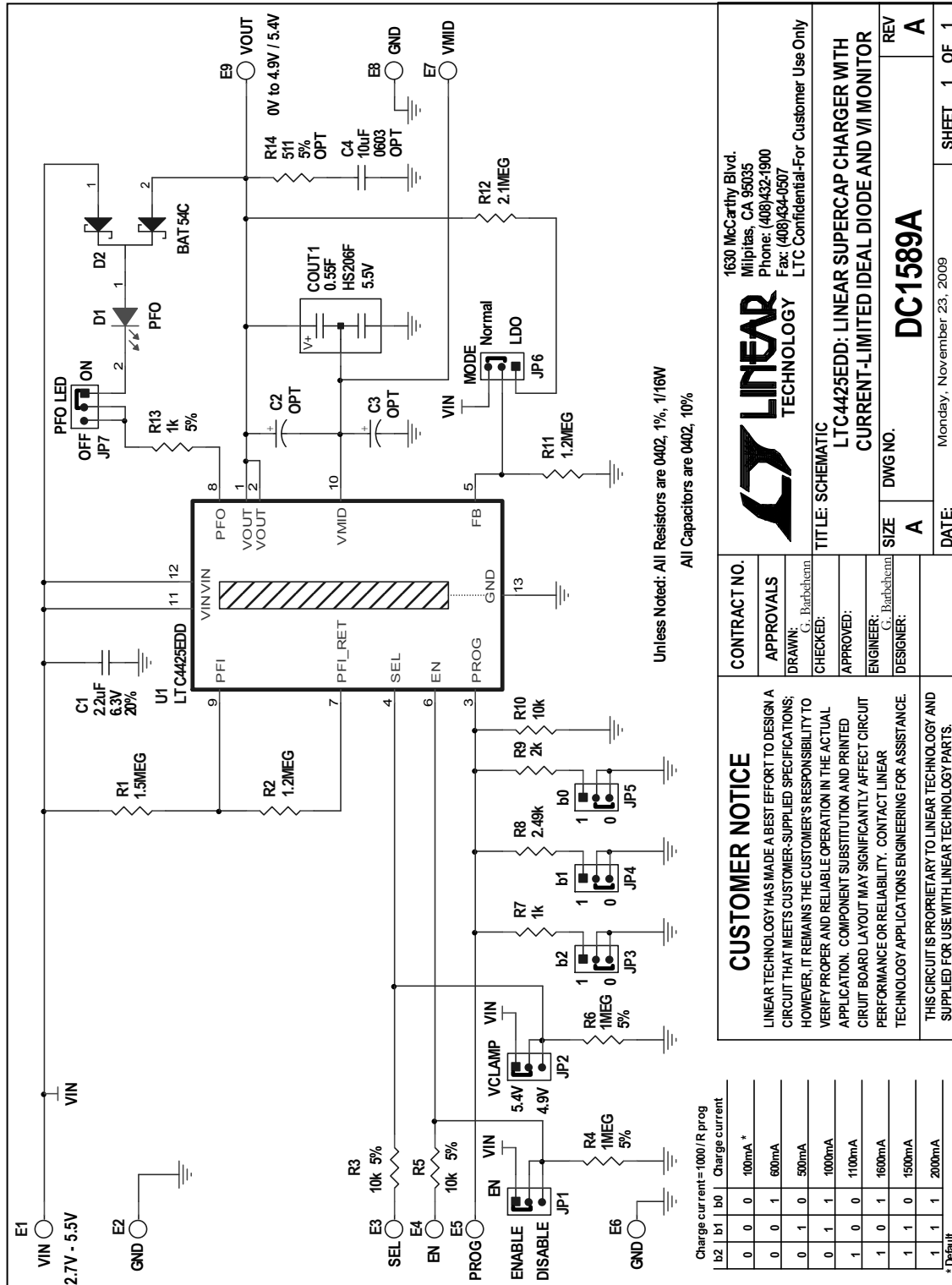

Figure 3. Circuit Schematic

CONTRACT NO.

APPROVALS

DRAWN: G. Barbicham

CHECKED:

APPROVED:

ENGINEER: G. Barbicham

DESIGNER:

1630 McCarthy Blvd.
Milpitas, CA 95035
Phone: (408)432-1900
Fax: (408)434-0507
LTC Confidential-For Customer Use Only

LINEAR TECHNOLOGY

TITLE: SCHEMATIC

LTC4425EDD: LINEAR SUPERCAP CHARGER WITH CURRENT-LIMITED IDEAL DIODE AND VI MONITOR

REV A

SIZE A

DWG NO. DC1589A

DATE: Monday, November 23, 2009

SHEET 1 OF 1

CUSTOMER NOTICE

LINEAR TECHNOLOGY HAS MADE A BEST EFFORT TO DESIGN A CIRCUIT THAT MEETS CUSTOMER-SUPPLIED SPECIFICATIONS; HOWEVER, IT REMAINS THE CUSTOMER'S RESPONSIBILITY TO VERIFY PROPER AND RELIABLE OPERATION IN THE ACTUAL APPLICATION. COMPONENT SUBSTITUTION AND PRINTED CIRCUIT BOARD LAYOUT MAY SIGNIFICANTLY AFFECT CIRCUIT PERFORMANCE OR RELIABILITY. CONTACT LINEAR TECHNOLOGY APPLICATIONS ENGINEERING FOR ASSISTANCE

THIS CIRCUIT IS PROPRIETARY TO LINEAR TECHNOLOGY AND SUPPLIED FOR USE WITH LINEAR TECHNOLOGY PARTS.

	Qty	Reference	Part Description	Manufacture / Part #
REQUIRED CIRCUIT COMPONENTS:				
1	1	C1	CAP, CHIP, X5R, 2.2 μ F, \pm 2%, 6.3V, 0402	MURATA, GRM155R60J225ME15D
2	1	COUT1	SUPERCAP, 0.55F, 80m Ω , 5.5V, 39mmX17mmX2.4mm	CAP-X, HS206F
3	1	R1	RES, CHIP, 1.5MEG Ω , \pm 1%, 1/16W, 0402	VISHAY, CRCW04021M50FKED
4	2	R2, R11	RES, CHIP, 1.2MEG Ω , \pm 1%, 1/16W, 0402	VISHAY, CRCW04021M20FKED
5	2	R3, R5	RES, CHIP, 10k Ω , \pm 5%, 1/16W, 0402	VISHAY, CRCW040210K0JNED
6	2	R4, R6	RES, CHIP, 1MEG Ω , \pm 5%, 1/16W, 0402	VISHAY, CRCW04021M00JNED
7	1	R7	RES, CHIP, 1k Ω , \pm 1%, 1/16W, 0402	VISHAY, CRCW04021K00FKED
8	1	R8	RES, CHIP, 2.49k Ω , \pm 1%, 1/16W, 0402	VISHAY, CRCW04022K49FKED
9	1	R9	RES, CHIP, 2k Ω , \pm 1%, 1/16W, 0402	VISHAY, CRCW04021K00JNED
10	1	R9	RES, CHIP, 2k Ω , \pm 1%, 1/16W, 0402	VISHAY, CRCW04022K00FKED
11	1	R10	RES, CHIP, 10k Ω , \pm 1%, 1/16W, 0402	VISHAY, CRCW040210K0FKED
12	1	R12	RES, CHIP, 2.1MEG Ω , \pm 1%, 1/16W, 0402	VISHAY, CRCW04022M10FKED
13	1	R13	RES, CHIP, 1k Ω , \pm 5%, 1/16W, 0402	VISHAY, CRCW04021K00JNED
14	1	U1	IC, SMT, Linear Supercap Charger with Current-limited Ideal Diode and V/I Monitor	LINEAR TECH., LTC4425EDD
ADDITIONAL DEMO BOARD CIRCUIT COMPONENTS:				
1	0	C2-OPT, C3-OPT	SUPERCAP 2.5V or 2.7V	User supplied
2	0	C4-OPT	CAP, CHIP, X5R, 10 μ F, \pm 10%, 6.3V, 0603	TDK, C1608X5R0J106K
3	1	D1	DIODE, LED, RED, 0603	PANASONIC, LNJ208R8ARA
4	1	D2	DIODE, Dual SCHOTTKY, 30V, 200mA, SOT-23	DIODE INC, BAT54C
5	0	R14-OPT	RES, CHIP, 511 Ω , \pm 5%, 1/16W, 0402	VISHAY, CRCW0402511RJNED
HARDWARE FOR DEMO BOARD ONLY:				
1	9	E1, E9	TURRET, 0.09 DIA	MILL-MAX, 2501-2-00-80-00-00-07-0
2	7	JP1-7	3 Pin Jumper, 2mm	SAMTEC, TMM-103-02-L-S
3	7	JP1-7	SHUNT, 2mm	SAMTEC, 2SN-KB-G
4	4		STAND-OFF, NYLON, 0.375"	KEYSTONE, 8832

Figure 4. Bill of Materials