

ENGINEERING NO.	CIRCUITS	IN	mm
73202-A-C-XX	2	.97	24.6
73203-A-C-XX	3	1.40	35.6
73204-A-C-XX	4	1.84	46.7
73205-A-C-XX	5	2.28	57.9
73206-A-C-XX	6	2.72	69.1
73207-A-C-XX	7	3.15	80.0
73208-A-C-XX	8	3.59	91.2
73209-A-C-XX	9	4.03	102.4
73210-A-C-XX	10	4.47	113.4
73211-A-C-XX	11	4.90	124.5
73212-A-C-XX	12	5.34	135.6
73213-A-C-XX	13	5.78	146.8
73214-A-C-XX	14	6.22	158.0
73215-A-C-XX	15	6.65	168.9
73216-A-C-XX	16	7.09	180.1
73217-A-C-XX	17	7.53	191.3
73218-A-C-XX	18	7.97	202.4
73219-A-C-XX	19	8.40	213.4
73220-A-C-XX	20	8.84	224.5
73221-A-C-XX	21	9.28	235.7
73222-A-C-XX	22	9.72	246.9
73223-A-C-XX	23	10.15	257.8
73224-A-C-XX	24	10.59	269.0
73225-A-C-XX	25	11.03	280.2
73226-A-C-XX	26	11.47	291.3
73227-A-C-XX	27	11.90	302.3
73228-A-C-XX	28	12.34	313.4
73229-A-C-XX	29	12.78	324.6
73230-A-C-XX	30	13.22	335.8

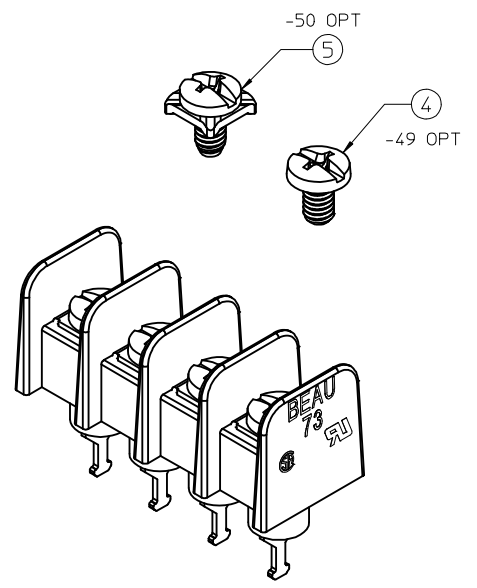

- NOTES:
- MATERIAL: SEE TABLE
 - FINISHES: SEE TABLE
 - ELECTRICAL SPECIFICATIONS
VOLTAGE RATING: 300V (10 AWG WIRE)
CURRENT RATING: 30 AMPS (#8 SCREW)
 - WIRE RANGE: 10-24 AWG
 - WIRE STRIP: .31 (8mm)
 - SCREW TORQUE: 12 IN. LBS.
 - PROD SPEC: PS-38730-001
 - UL FILE E48521
 - XX = NUMBER OF CIRCUITS

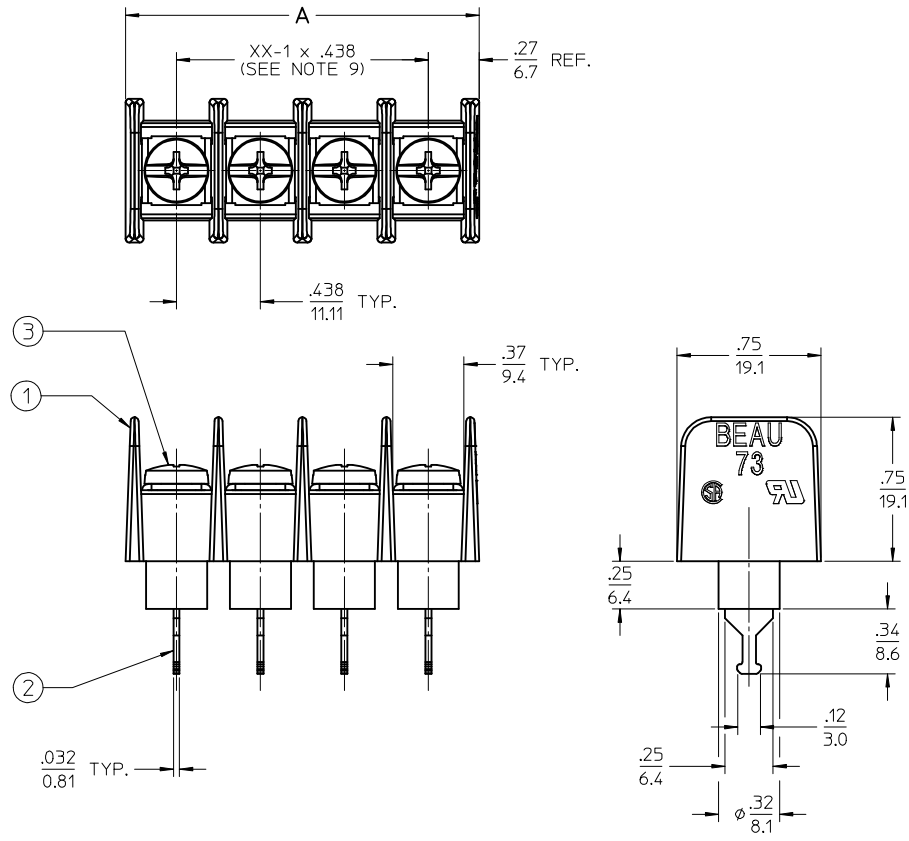
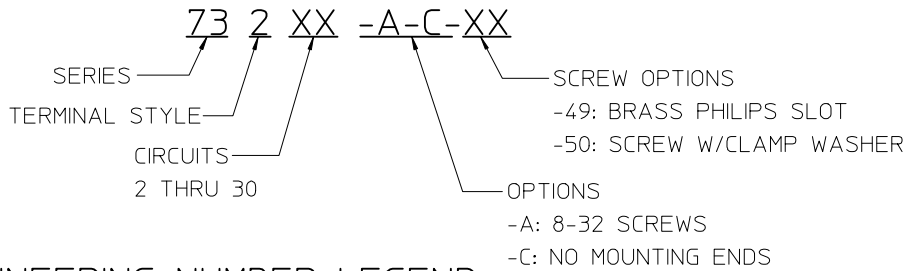

ENGINEERING NUMBER LEGEND

ITEM	QTY.	DESCRIPTION	MATERIAL	FINISH
5	XX	SCREW #8-32 X .31 PAN HD PHSL W/SQ WASHER -50	STEEL	ZINC PLATED
4	XX	SCREW #8-32 X .29 BHD PHSL -49	BRASS	NICKEL PLATED
3	XX	SCREW #8-32X.29 BHD PHSL LUBE	STEEL	ZINC PLATED
2	XX	TERM TURRET 6C SN/B	BRASS	TIN PLATED
1	1	SR BARRIER TERMINAL STRIP, NO MTG ENDS	PBT	BLACK

RELEASED	EC NO: JPC2015-1766	2015/04/09
DRWNR: STONE	CHKD: B ARDEN	APPR: J MURPHY
DESCRIPTION	2015/04/20	

QUALITY SYMBOLS	GENERAL TOLERANCES (UNLESS SPECIFIED)
▽=0	mm INCH
▽=0	4 PLACES ± .005 ± .005
	3 PLACES ± .005 ± .005
	2 PLACES ± 0.13 ± .01
	1 PLACE ± 0.3 ± .01
	0 PLACE ± .005 ± .005
	ANGULAR ± 2°
	DRAFT WHERE APPLICABLE MUST REMAIN WITHIN DIMENSIONS

DRAWN BY	DATE
RSTONE	2015/04/09
CHECKED BY	DATE
B ARDEN	
APPROVED BY	DATE
JFMURPHY	2015/04/20
MATERIAL NO.	DOCUMENT NO.
SEE CHART	SD-38731-010

SCALE	DESIGN UNITS	THIRD ANGLE PROJECTION
2:1	INCH	
TITLE		
SINGLE ROW BARRIER STRIP INSULATED SOLDER TURRET NO MTG ENDS, #8 SCREW		
molex		
DOCUMENT NO.		SHEET NO.
SD-38731-010		1 OF 1
THIS DRAWING CONTAINS INFORMATION THAT IS PROPRIETARY TO MOLEX INCORPORATED AND SHOULD NOT BE USED WITHOUT WRITTEN PERMISSION		