

# APPROVAL SHEET

**Product Name:** Quartz Thermistor Resonator

**P/N.:** ECS-260-7-37TC-CZY-TR

**Customer's Name:** \_\_\_\_\_

**Specification Sheet#:** \_\_\_\_\_

**Date:** 12/30/2020

**Draw:** A. Anderson

**Check:** D. Kelly

**Customer Confirmation:** \_\_\_\_\_



## ECS Inc. International

TEL: 913-782-7787

FAX: 913-782-6991

http: [www.ecsxtal.com](http://www.ecsxtal.com)



# ECS Inc. International

## ■ REVISION HISTORY

NO.	DATE	EDITION	DRAW
1	12/30/2020	First Edition	A. Anderson
2			
3			
4			
5			
6			
7			
8			
9			
10			
11			
12			
13			
14			
15			
16			
17			
18			
19			
20			
21			
22			
23			
24			
25			
26			
27			
28			
29			
30			
31			
32			
33			
34			
35			
36			
37			



**1. SCOPE**

This specification relates to the Quartz Crystal to be supplied by ECS Inc International.

**2. SPECIFICATION**

**2-1. ELECTRICAL SPECIFICATION**

Parameter	Value	Condition
Nominal Frequency	26.000000 MHz	
Mode of Vibration	AT-cut fundamental	
Operating Temperature Range	-30 ~ +85°C	
Storage Temperature Rangel	-40 ~ +105°C	
Drive level	10uW Typ., 100uW Max.	
Loading Capacitance	7 pF	
Test Set	250B PI-Network	
Initial Frequency Tolerance	±10 ppm Max.	TA= +25°C
Tolerance Over Temperature	±12 ppm Max.	TA= -30 ~ +85°C
Aging	±0.7ppm Max.	Per Year
Equivalent Series Resistance	50Ω Max.	
Spurious Mode Resistance	1100Ω Min.	±1MHz
Insulation resistance	500 MΩ Min.	
Inflection Point	30.5 ±1.5°C	
Coefficient range (referenced to 32°C) Note1	C1: -0.40 ~ -0.10ppm/°C C2: -4.5*10 <sup>-4</sup> ~ 4.5*10 <sup>-4</sup> ppm/°C C3: 8.7*10 <sup>-5</sup> ~ 11.0*10 <sup>-5</sup> ppm/°C	
Thermistor Resistance(25°C)	100 Kohms ±1%	TA= +25°C
Thermistor B-constant (25~50°C)	4250 K ±1%	TA= +25 ~ +50°C



**Note1**

The FT curve of an AT-cut crystal can be modeled as a third -order polynomial.

C0, C1, C2, and C3 are coefficients that need to be defined are calculated in the order specified

$$f(t) = c_3(\theta)(t-t_0)^3 + c_2(\theta)(t-t_0)^2 + c_1(\theta)(t-t_0) + c_0$$

C0, C1, C2, and C3 are coefficients that need to be defined.

**C1: First-order Curve Fitting Parameter**

**C2: Second-order Curve Fitting Parameter**

**C3: Third-order Curve Fitting Parameter/T0=+30.5°C**

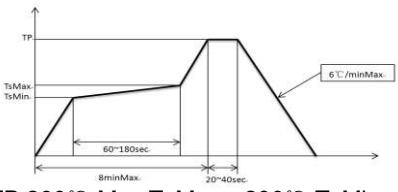

**2-2. RELIABILITY TEST**

NO	ITEM	CONDITIONS	BASIS OF VERDICT
1	HIGH TEMPERATURE STORAGE	Temperature: 85°C Times: 1000 hours The test was conducted 24 ±2 hours at the end of the test(no charge)	$\Delta FL \leq \pm 10$ ppm $\Delta RS \leq 5 \Omega$ or $\pm 20\%$ (Whichever is Larger)
2	CONSTANT HUMIDITY	Temperature: 85°C ±2°C; Humidity: 85%; Time: 1000 hours The test was conducted 24 ±2 hours at the end of the test	$\Delta FL \leq \pm 10$ ppm $\Delta RS \leq 5 \Omega$ or $\pm 20\%$ (Whichever is Larger)
3	LOW TEMPERATURE STORAGE	Temperature: -40°C Time: 1000 hours The test was conducted 24 ±2 hours at the end of the test	$\Delta FL \leq \pm 10$ ppm $\Delta RS \leq 5 \Omega$ or $\pm 20\%$ (Whichever is Larger)
4	TEMPERATURE CYCLING	-55°C ±2°C (5 min) <sup>5 min</sup> → 125°C ±2°C (5 min); For 1000 cycles Maximum conversion time: 5 min High/Low temperature holding time: 30 min	$\Delta FL \leq \pm 10$ ppm $\Delta RS \leq 5 \Omega$ or $\pm 20\%$ (Whichever is Larger)
5	DROP	Height: 1m; 3 times	$\Delta FL \leq \pm 10$ ppm $\Delta RS \leq 5 \Omega$ or $\pm 20\%$ (Whichever is Larger)
6	MECHANICAL SHOCK	Peak: 100g's Duration: 6ms Waveform: Half-sine Velocity Change: 12.3 ft / sec Direction: +X, -X, +Y, -Y, +Z, -Z 3 times/direction Conduct electrical performance tests	$\Delta FL \leq \pm 10$ ppm $\Delta RS \leq 5 \Omega$ or $\pm 20\%$ (Whichever is Larger)
7	VIBRATION	Frequency: 10~2000Hz: Acceleration: 5g/s Direction: X, Y, Z Duration: 20min/direction. Times: 12次	$\Delta FL \leq \pm 10$ ppm $\Delta RS \leq 5 \Omega$ or $\pm 20\%$ (Whichever is Larger)
8	WELDING HEAT RESISTANT	 <p>TP: 260°C Max TsMax: 200°C TsMin: 150°C CYCLE TIME: 2次</p>	$\Delta FL \leq \pm 10$ ppm $\Delta RS \leq 5 \Omega$ or $\pm 20\%$ (Whichever is Larger)
9	SOLDER	Pretreatment before test: 155°C high-temperature store 4 hours Temperature: 260°C ±5°C, immersion	Solder Coverage $\geq$ 95%
10	TERMINAL STRENGTH	1.8kg, of the tangential thrust (60 s) 1.8kg of the perpendicular tension (60 s)	No Rupture Observed

### 3. Appearance

#### 3.1 Outline Dimensions and Recommended Land Pattern

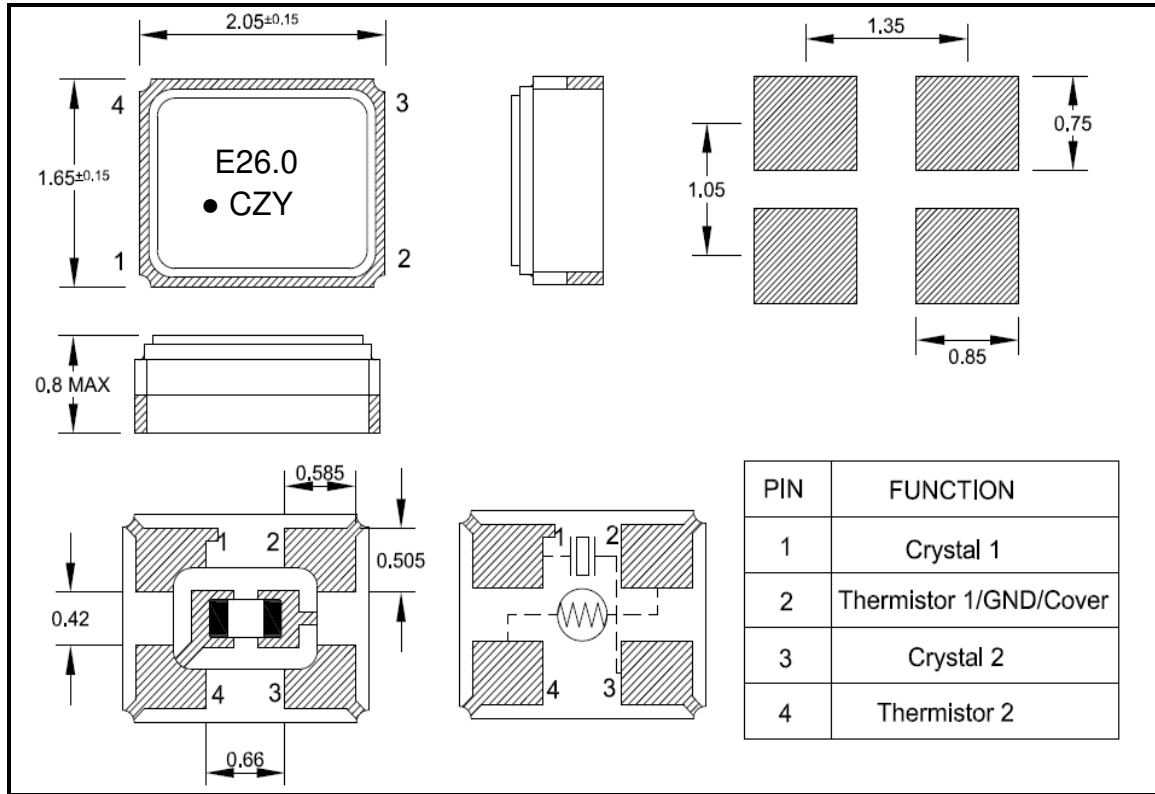

#### 3.2 Marking Information



#### Laser Marking

ITEM	Marking	REMARK
①	E	ECS Inc. International
②	26.0	26.000 MHz
③	CZY	Spec (±10/12ppm -30 ~ +85°C)
④	●	1# PIN

**4. TAPE AND REEL PACKING**

**4-1. TAPING SPECIFICATION**

**(1) Tape Dimensions**

**Material of Carrier Tape: Black conductive PS**

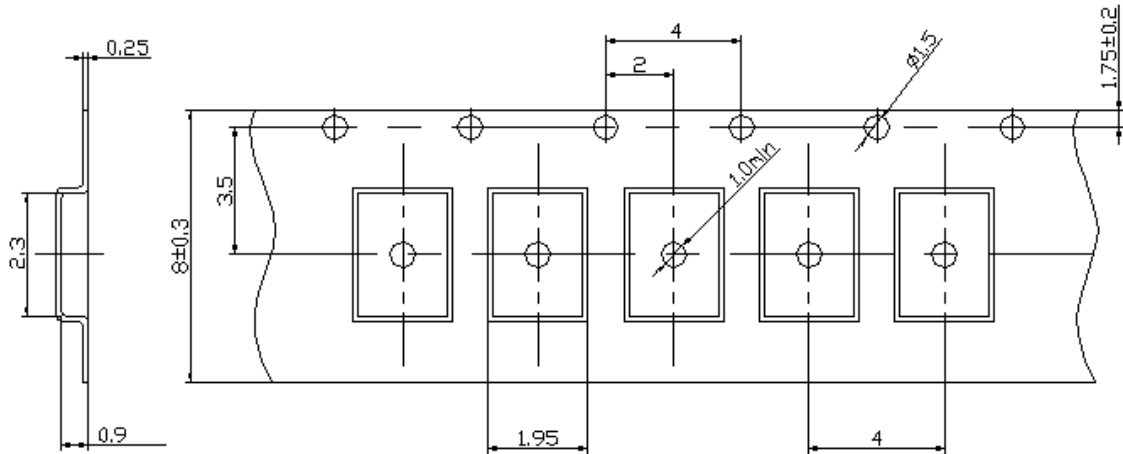

**(2) Reel Dimensions**

**Material of the Reel: PS**

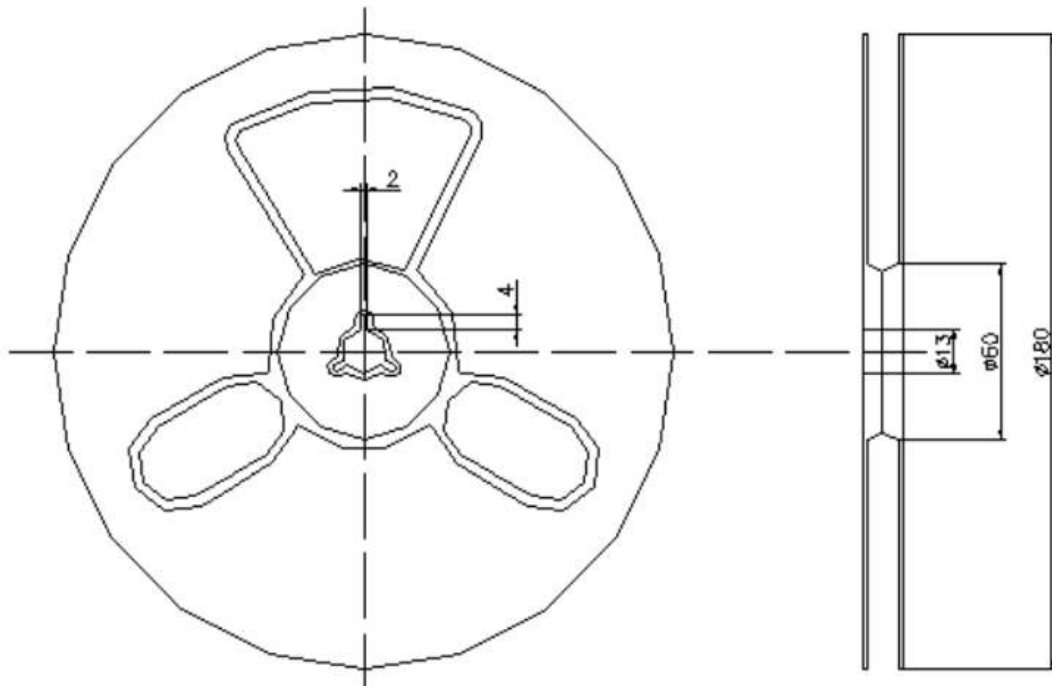

(3) Taping Method

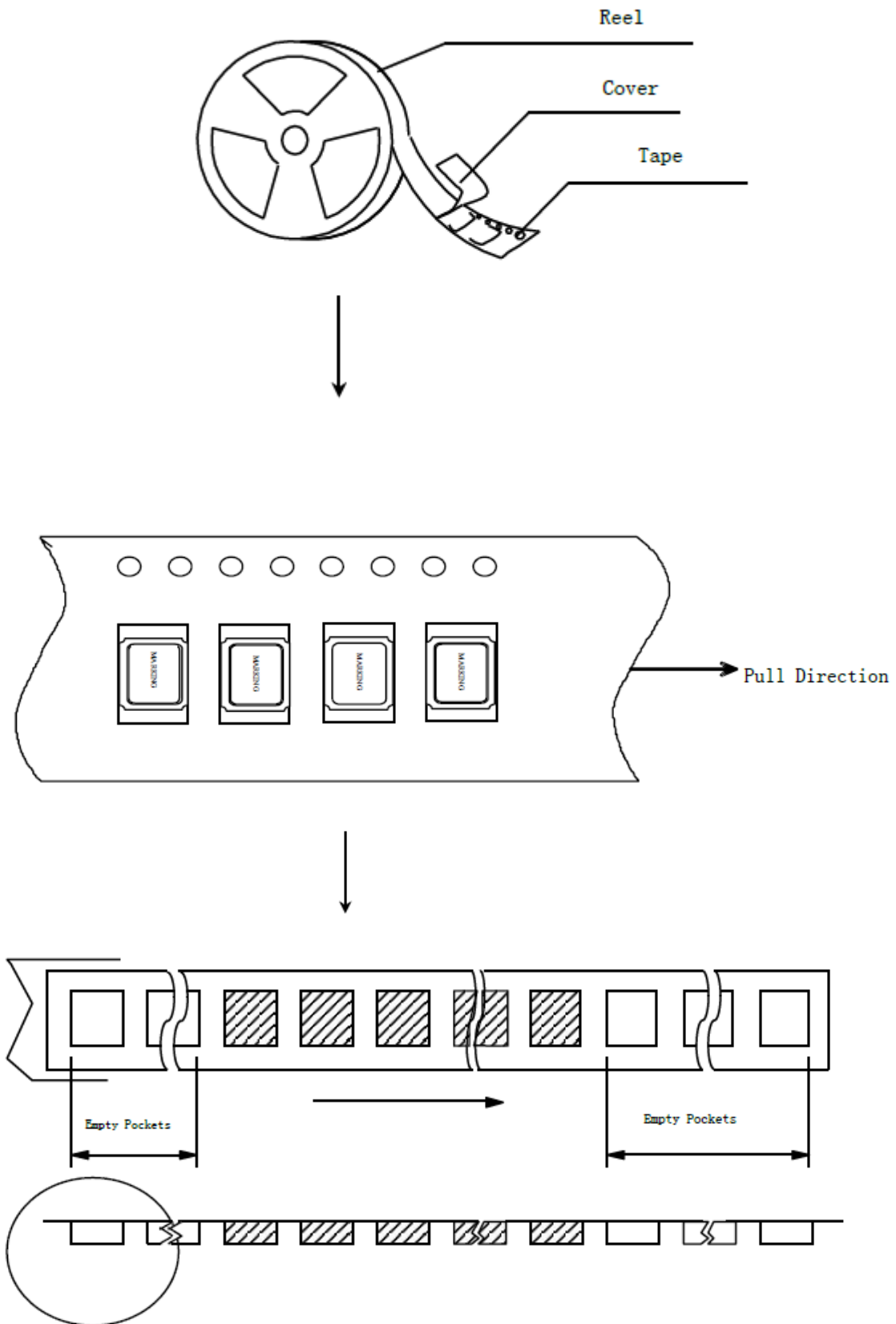





**3-2. Warehouse Condition**

(1) **Temperature: -10 ~ +40°C**

(2) **Humidity: 45% ~ 75%**