

PART NO.	ENGINEERING NO.	FINISHED LENGTH
1300060134	102001A01F030	3FT [0.9M]
1300060141	102001A01F120	12FT [3.7M]
1300062368	102001A01F600	60FT [18.3M]

PART NUMBER LEGEND

102001A01F030

CABLE LENGTH
 F050 = 5 FEET
 F100 = 10 FEET
 F150 = 15 FEET

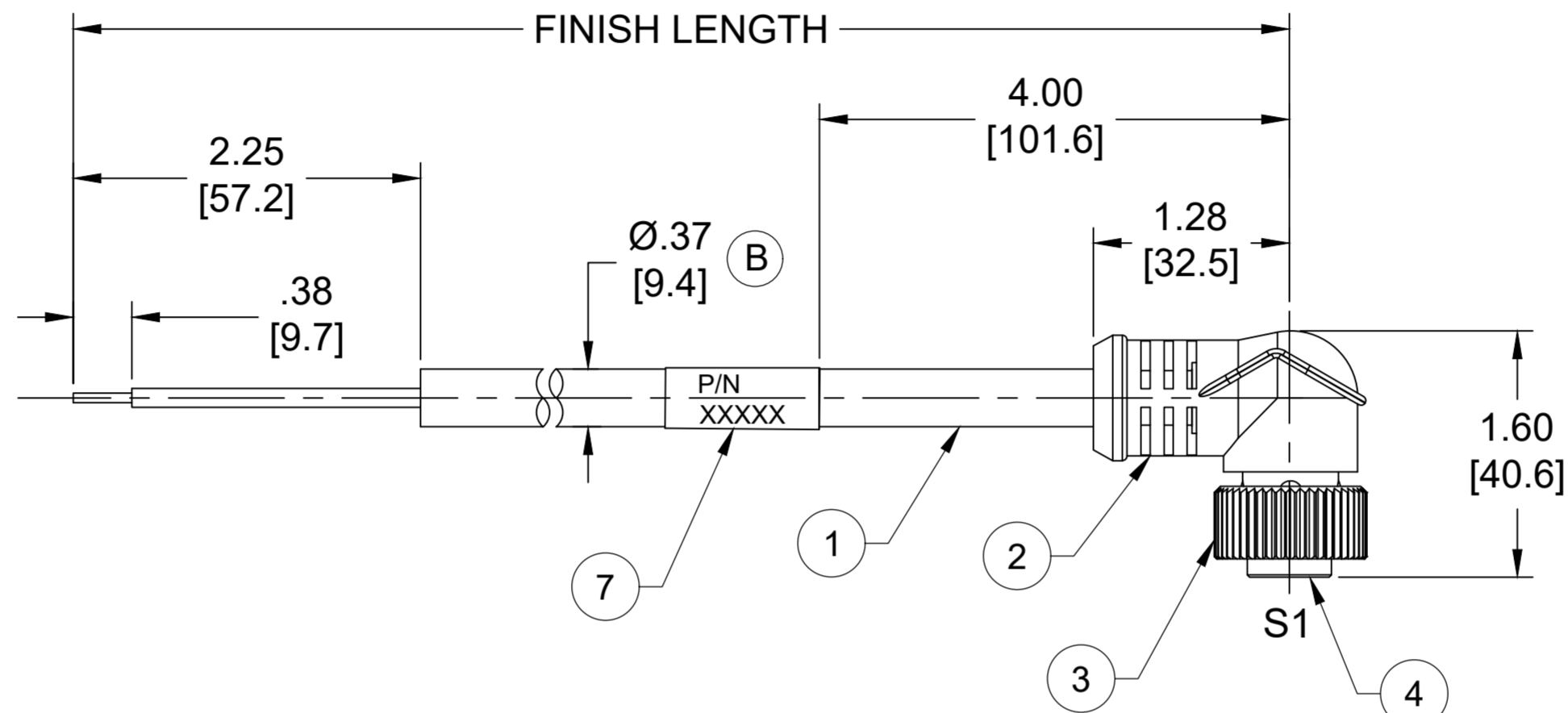
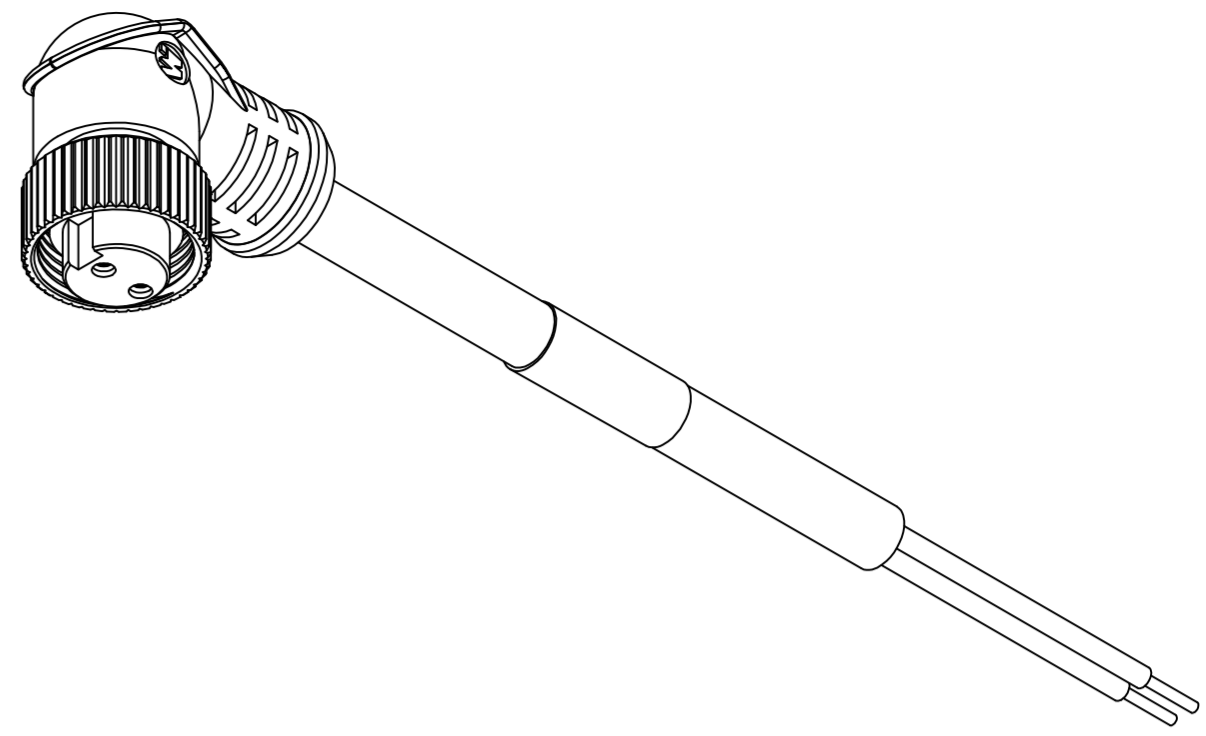

- NOTES:
- MATERIAL: AS NOTED
 - FINISH: AS NOTED
 - ELECTRICAL:
 VOLTAGE : 500V PER IEC60664
 600V PER UL2238
 CURRENT: 13A
 - TEMP RATING: -20° TO +105°C
 - PROTECTION: IP67 (WHEN MATED)
 - COUPLING THREAD: 7/8"-16UN
 - UL RECOGNIZED FILE: E152210
 CSA CERTIFIED FILE: LR6837
 - ALL DIMENSIONS ARE FOR REFERENCE UNLESS TOLERANCED OR NOTED OTHERWISE

	S1
WHITE	1
BLACK	2

WIRING DIAGRAM

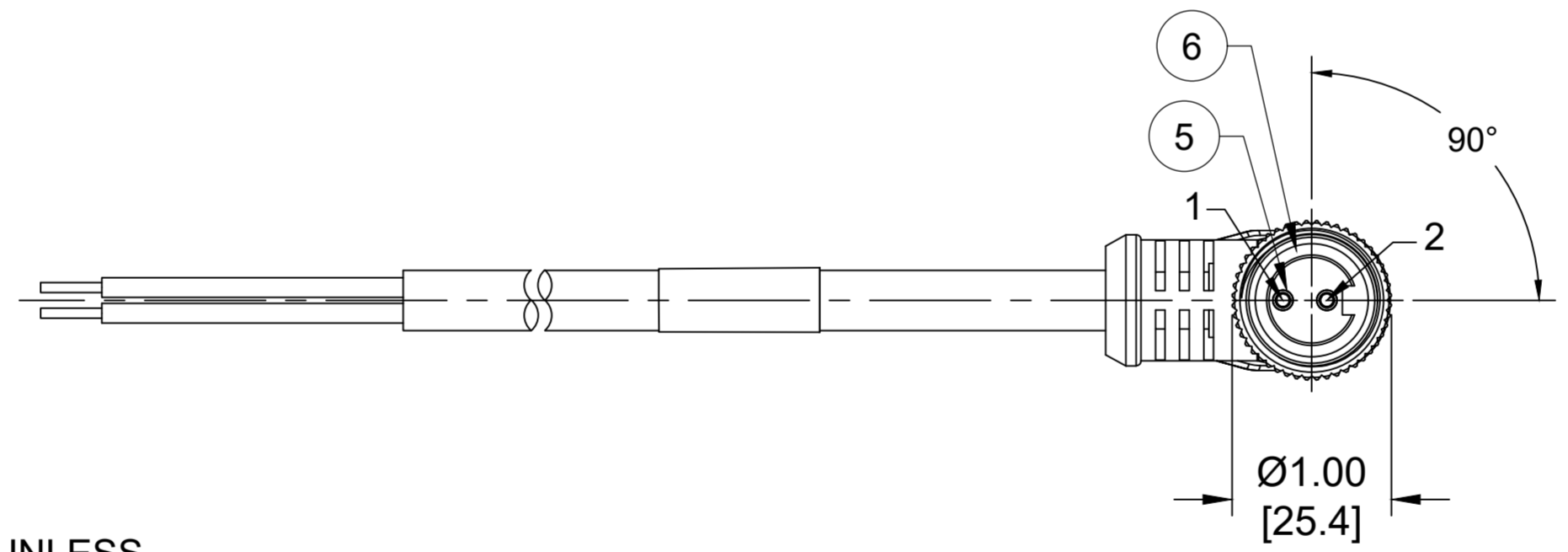

FEMALE FACE VIEW

CABLE LENGTH TOLERANCES

<.3M [1FT]:	+19mm-0 [+.75in-0]
.3 - .9M [1 - 3FT]:	+44.5mm-0 [+1.75in-0]
.9 - 1.8M [3 - 6FT]:	+55.6mm-0 [+2.19in-0]
1.8 - 3.7M [6 - 12FT]:	+88.9mm-0 [+3.50in-0]
3.7 - 7.3M [12 - 24FT]:	+165.1mm-0 [+6.50in-0]
7.3-14.6M [24 - 48FT]:	+317.5mm-0 [+12.50in-0]
14.6 - 30.5M [48-100FT]:	+622.3mm-0 [+24.50in-0]
OVER 30M [100FT]	+2% OF FINISHED LENGTH

ITEM	COMPONENT	MATERIAL	FINISH
7	WRAP LABEL	VINYL	BLACK/YELLOW
6	FRICITION RING	NYLON	WHITE
5	CONTACT SOCKET	COPPER ALLOY	GOLD OVER NICKEL
4	INSERT	TPE	YELLOW
3	COUPLING NUT	ZINC DIE CAST	BLACK-E-COAT
2	OVERMOLD	TPE	YELLOW
1	CABLE, 16 AWG STOOW/ST	PVC	YELLOW

THIS DRAWING CONTAINS INFORMATION THAT IS PROPRIETARY TO MOLEX ELECTRONIC TECHNOLOGIES, LLC AND SHOULD NOT BE USED WITHOUT WRITTEN PERMISSION

FUNCTIONAL SYMBOLS	DIMENSION UNITS	SCALE	CURRENT REV DESC: ITEM# 2 & 4 WERE PVC. ITEM #7 WAS PLASTIC FILM. ADDED FRICTION RING, IEC VOLTAGE, PN LEGEND, CABLE DIA & TOL CHART. MODIFIED PN CHART
FA=0	INCH/MM	NTS	
FC=0	GENERAL TOLERANCES (UNLESS SPECIFIED)		
FD=0	mm	INCH	
DIVISIONAL SYMBOLS	4 PLACES	±----	EC NO: 702709
	3 PLACES	±----	DRWN: ABENJAMINLW 2021/05/18
	2 PLACES	±----	CHK'D: RSTONE 2022/04/11
	1 PLACE	±----	APPR: BWOODMAN 2022/04/16
	0 PLACES	±----	INITIAL REVISION:
	ANGULAR TOL ± ---- °		DRWN: TWOLDEGE 2009/07/29
	DRAFT WHERE APPLICABLE MUST REMAIN WITHIN DIMENSIONS		APPR: JFMURPHY 2009/08/10
	THIRD ANGLE PROJECTION	DRAWING	SERIES
		C-SIZE	130006
		MATERIAL NUMBER	CUSTOMER
		SEE CHART	GENERAL MARKET
		DOCUMENT NUMBER	DOC TYPE/DOC PART/REVISION
		SD-130006-014	PSD 001 B
		SHEET NUMBER	1 OF 1