



Datasheet

Part No:
PA.25A

Description:

Anam Hexa-Band Cellular SMT Antenna
800 MHz to 2200 MHz

Features:

Compact High Efficiency Antenna
Surface Mount Device
Dimensions: 35*5*6mm
Manufactured in an IATF16949 Approved Facility
RoHS & REACH Compliant

1. Introduction	3
2. Specifications	4
3. Antenna Characteristics	5
4. Radiation Pattern	7
5. Mechanical Drawing	10
6. Eval Board Drawing	11
7. Antenna Integration Guide	12
8. Recommended Reflow Temperature Profile	20
9. Packaging	21
<hr/>	
Changelog	22

Taoglas makes no warranties based on the accuracy or completeness of the contents of this document and reserves the right to make changes to specifications and product descriptions at any time without notice. Taoglas reserves all rights to this document and the information contained herein. Reproduction, use or disclosure to third parties without express permission is strictly prohibited.



1. Introduction



The PA.25A is ceramic cellular antenna designed for in-device mounting. The PA.25A is mounted through SMT process and can be used in varying applications based on it's small form factor of just 35*6*5mm.

Typical Applications Include:

- Body Worn Devices
- Hand-held IoT Devices
- Remote Monitoring

This ceramic multiband cellular antenna uses high grade ceramics which have been developed in Taoglas through years of expertise in delivering the right materials for high performance antennas. Taoglas, through constant research and development have designed a small form factor high efficiency antenna for use across cellular bands from 800MHz to 2170MHz.

The PA.25A is manufactured and tested in our IATF16949 approved facility.

The PA.25 is a unique SMT solution which is delivered on tape and reel. For very detailed integration information additional to this specification please download our comprehensive PA.25 integration application note from our website. For further information, please contact your regional Taoglas customer support team.

2. Specifications

Electrical									
Band	Frequency (MHz)	Efficiency (%)	Average Gain (dB)	Peak Gain (dBi)	VSWR	Impedance	Polarization	Radiation Properties	Max Input Power
4G/3G/NB-IoT/Cat M Band 5,8,18,19,20,26,27	824~960	70	-1.55	2.00	<3:1	50Ω	Linear	Omnidirectional	5W
4G/3G Band 1,2,3,4,9,23,25,35,39,66	1710~2200	58	-2.39	3.51					
Mechanical									
Dimensions (mm)	35mm X 5mm X 6mm								
Material	Ceramic								
Termination	Ag (environmental-friendly Pb free)								
Weight	3g								
EVB Connector	SMA-Female								
Environmental									
Operation Temperature	-40°C to 85°C								
Storage Temperature	-40°C to 105°C								
Moisture Sensitivity	Level 3								
RoHs Compliant	Yes								
REACH Compliant	Yes								

* The antenna was tested on a 110*40mm ground plane and covered by 2mm thick ABS plastic.

* Actual Antenna Electrical performance will depend on customer ground plane size.

3. Antenna Characteristics

3.1 Return Loss

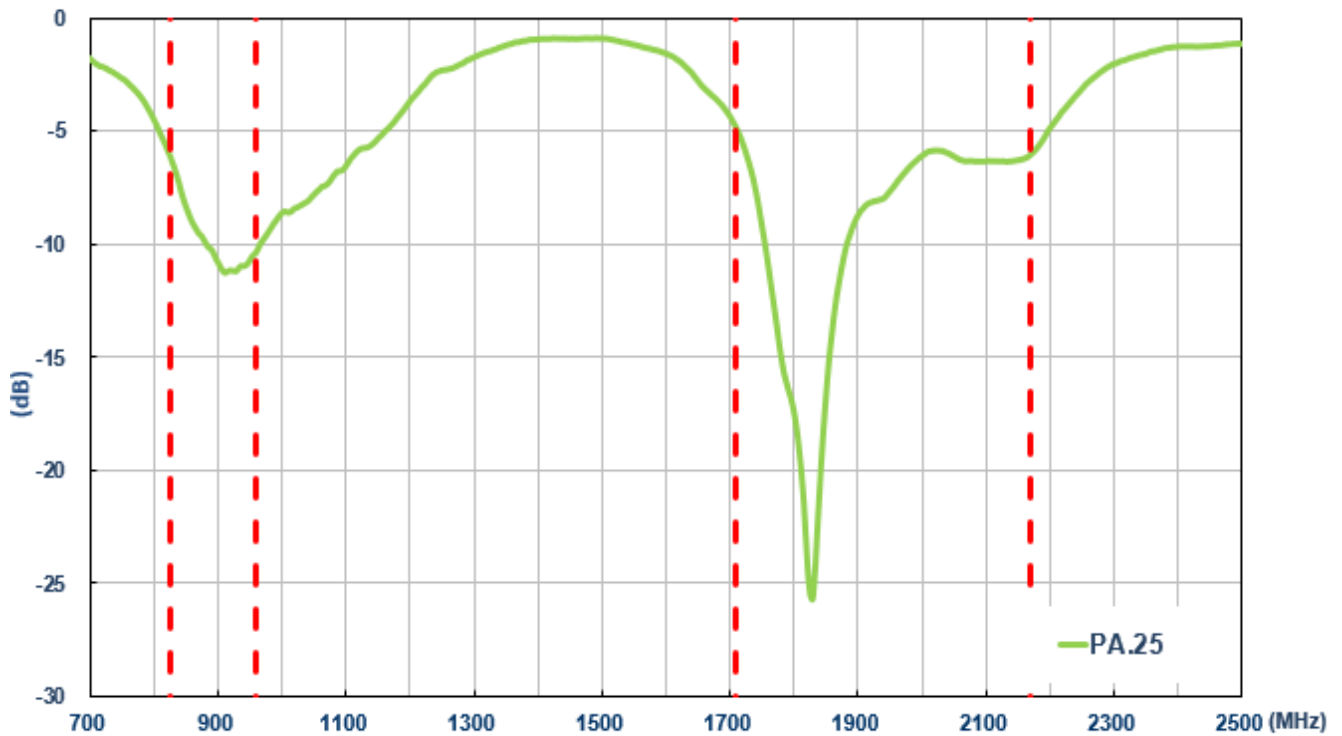

3.2 Efficiency

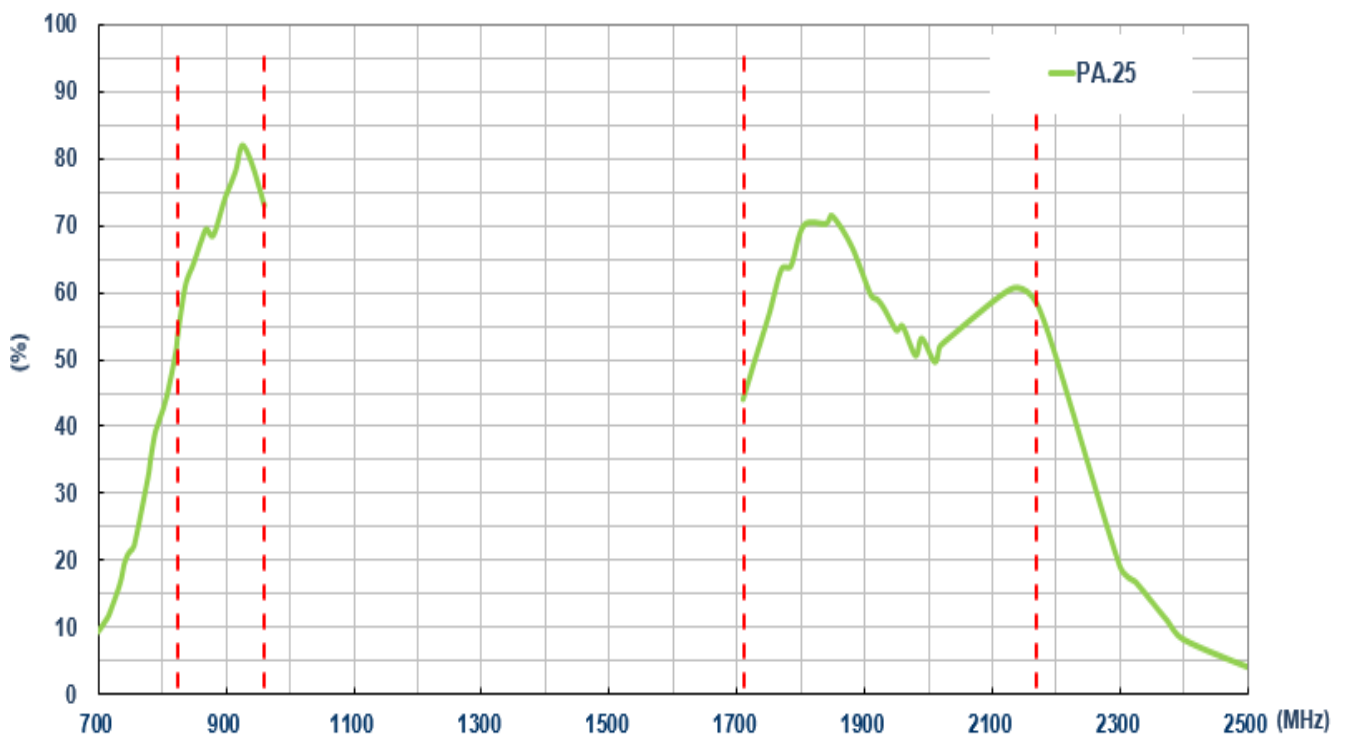

3.3 Peak Gain

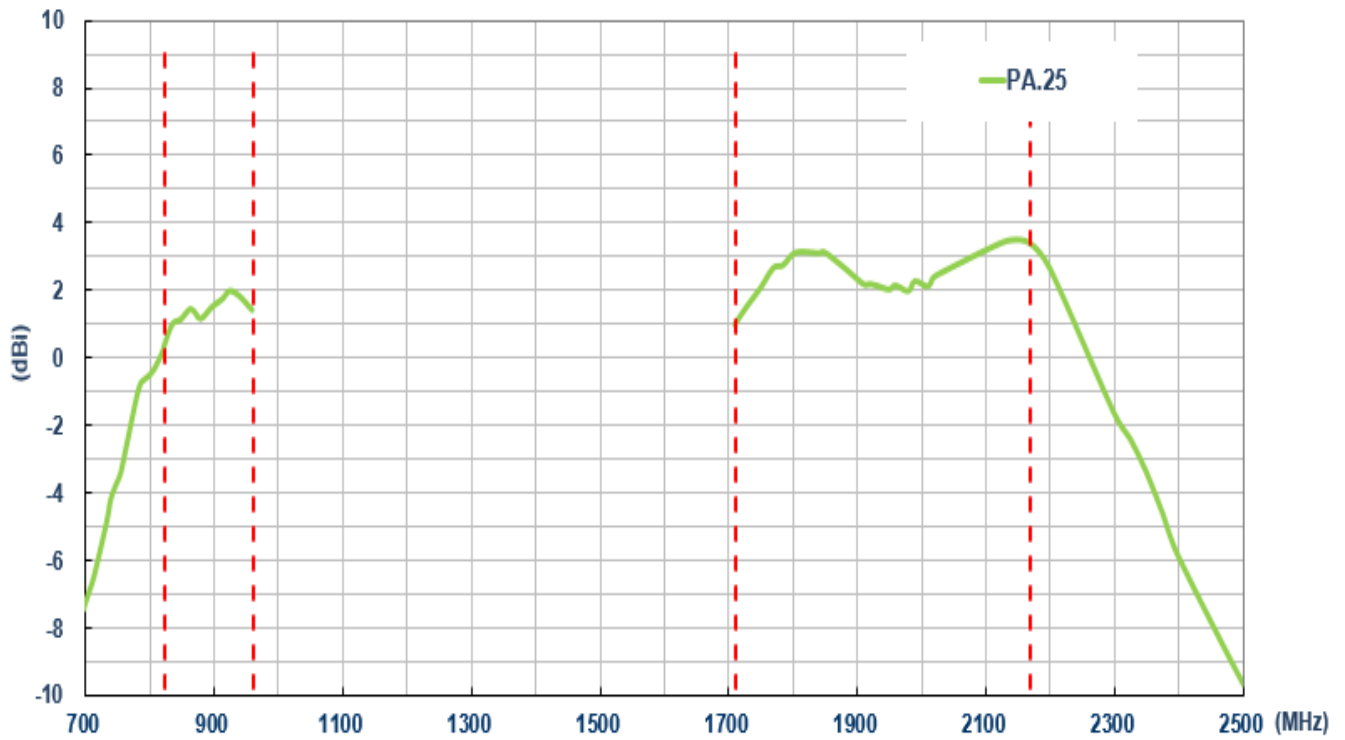

3.4 Average Gain

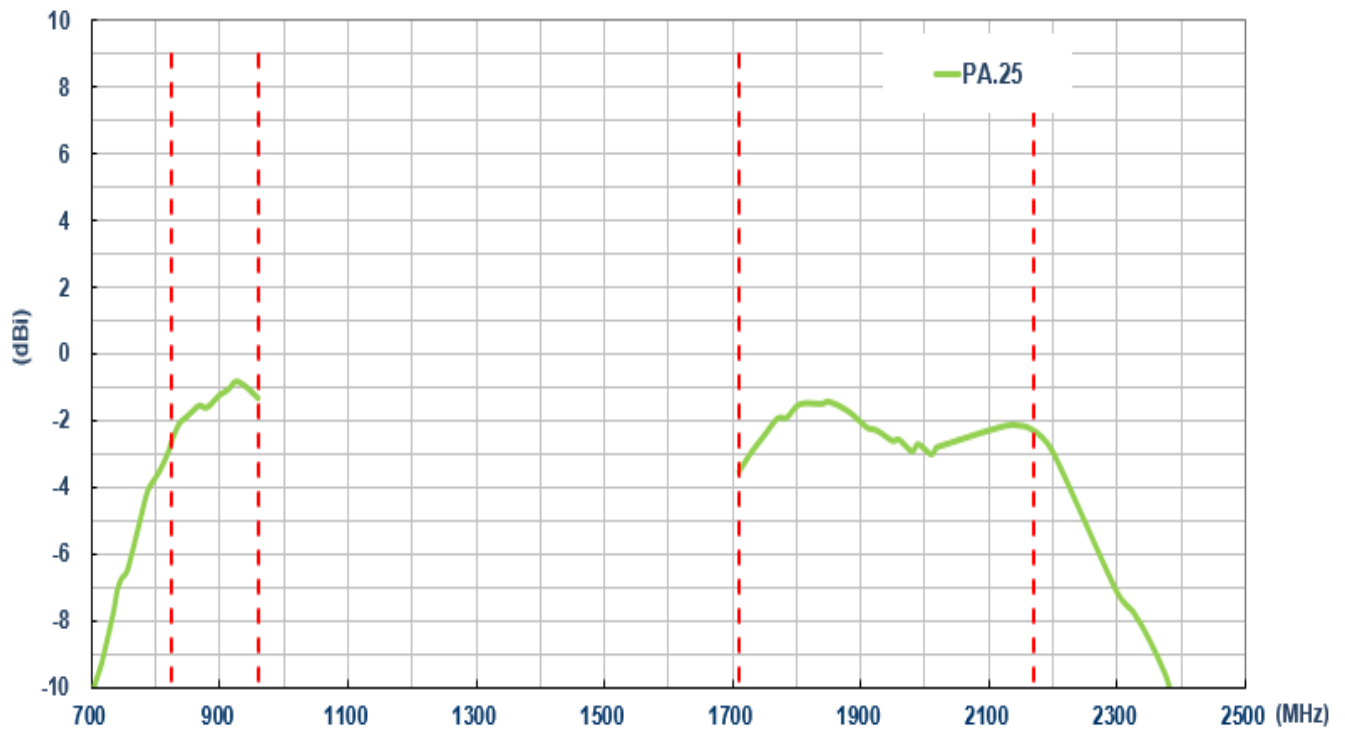

4. Radiation Pattern

4.1 Test Setup on PAD.25 Evaluation Board



Chamber Test Set-up

4.2 824/960MHz 3D and 2D Radiation Patterns

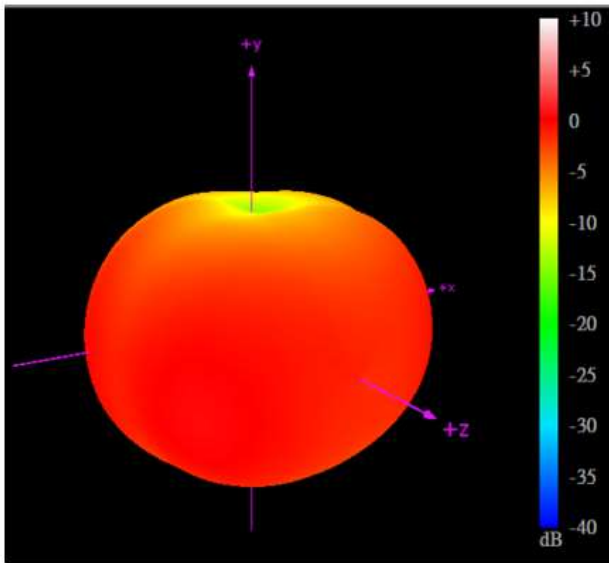

824MHz

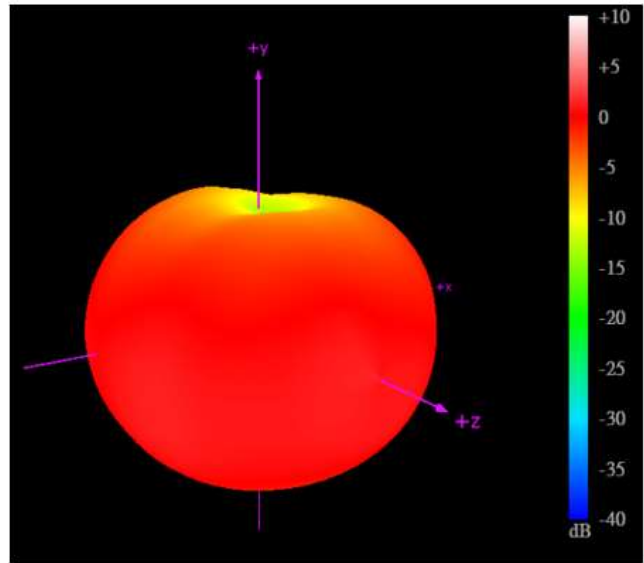

960MHz

XY Plane

XZ Plane

YZ Plane

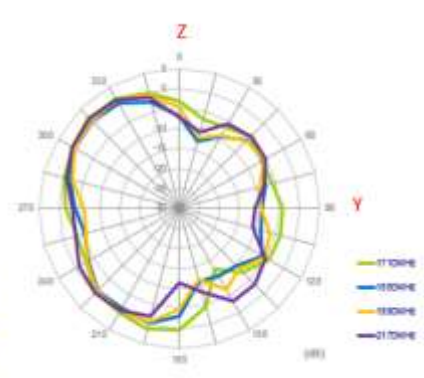
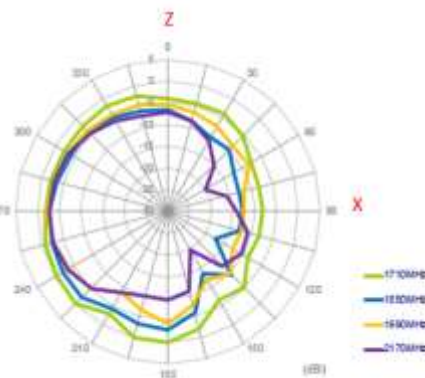
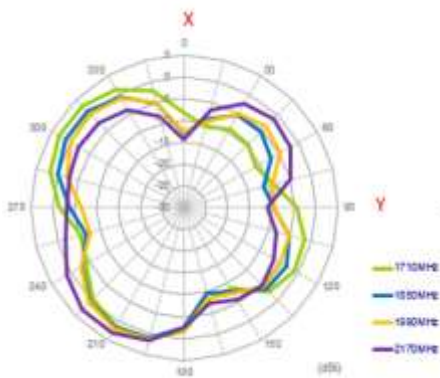

1710/1850MHz

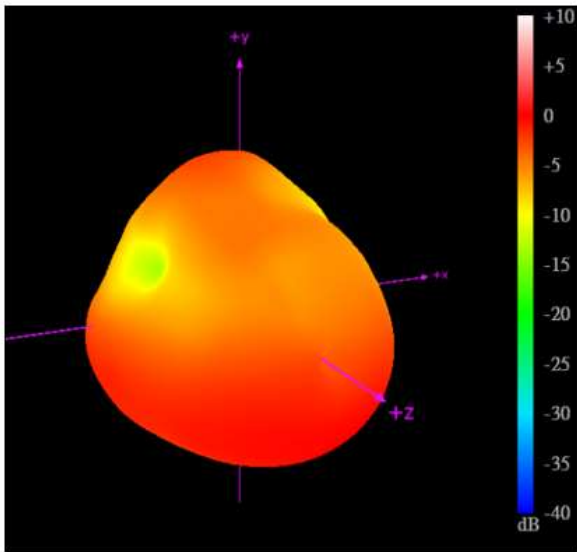

1710MHz

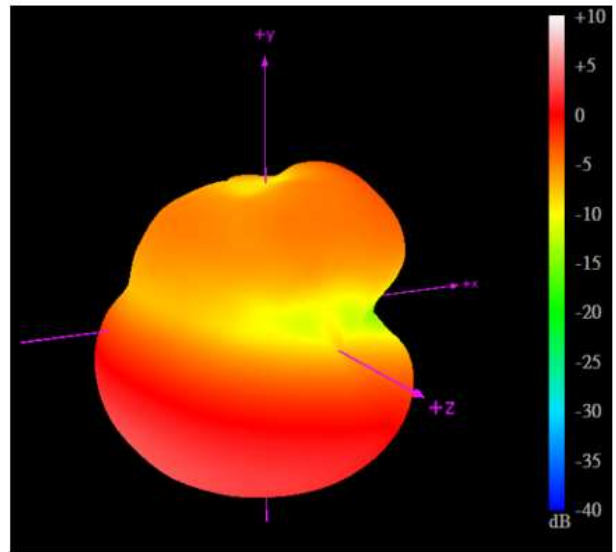

1850MHz

XY Plane

XZ Plane

YZ Plane

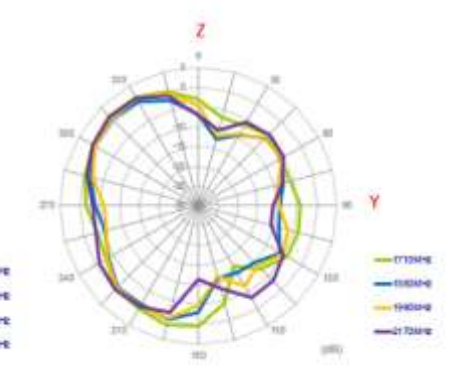
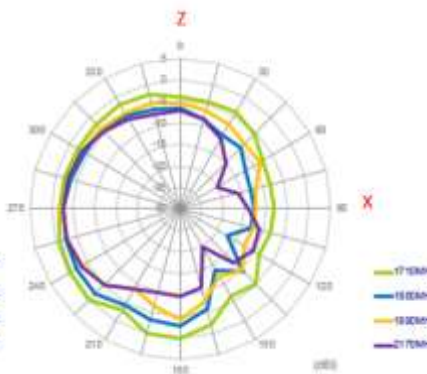
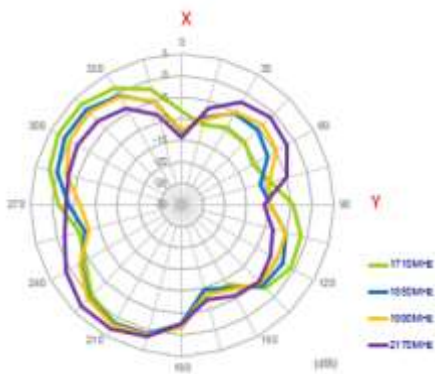

5. Mechanical Drawings (Unit:mm)

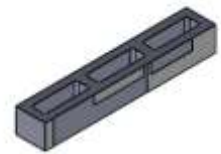
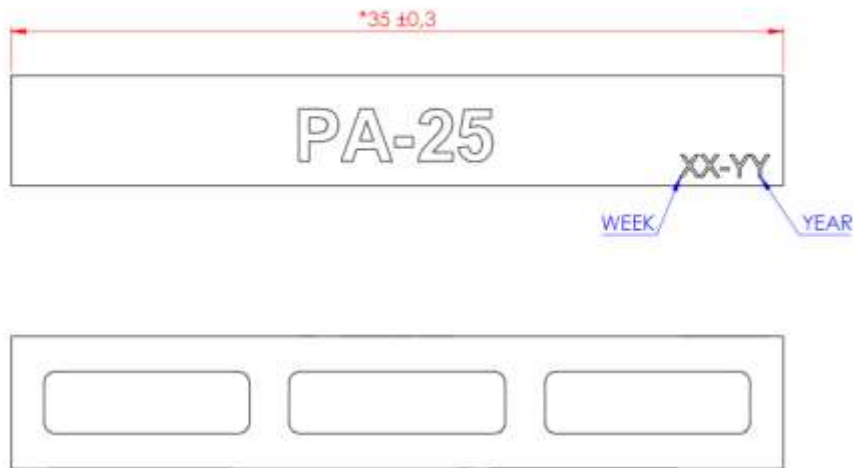

ANTENNA VIEW
2:1



ANTENNA VIEW
2:1



ANTENNA SOLDER PAD CONTACT AREA
WITH FOOTPRINT PCB

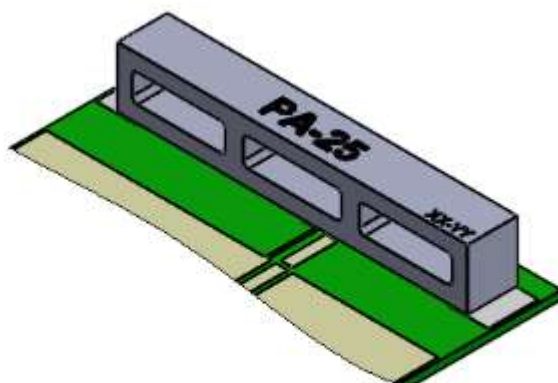
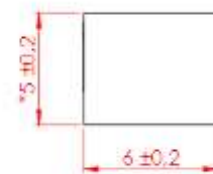

ANTENNA ON FOOTPRINT PCB VIEW
SCALE 2:1

PIN:	DESCRIPTION:
1	RF FEED (50 Ohm)
2	GROUND
3,4	NOT CONNECTED

6. Eval Board Drawing (Unit: mm)

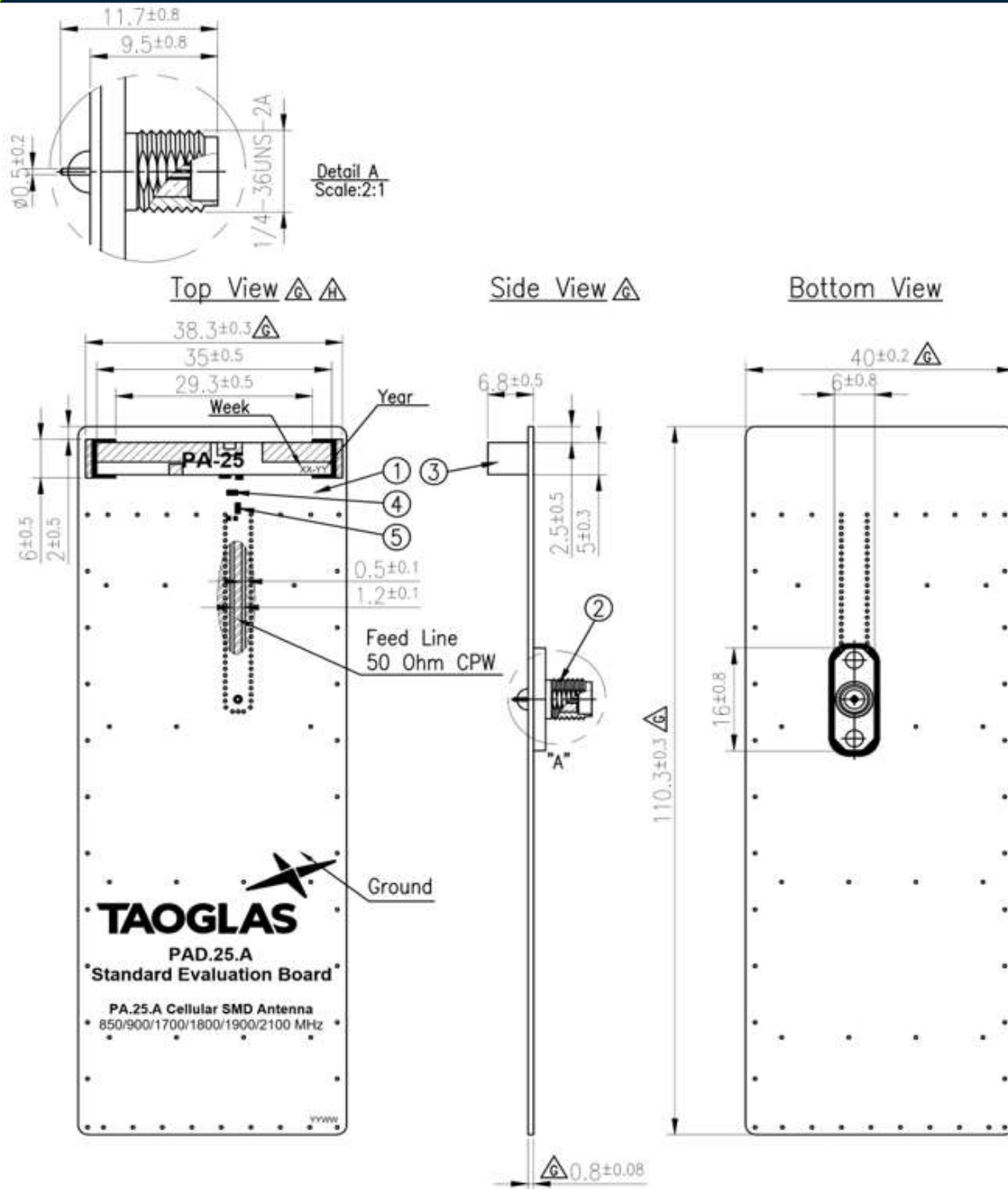

Note:

- 1. Week Batch Code
Example: 2010 Week 1=01.10
- 2. Silver
- 3. Soldered
- 4. Logo & Text Ink Printing : White

	Name	P/N	Material	Finish	QTY
1	PA.25.A EVB PCB	100211G040052A	Composite 0.8t	Black	1
2	SMA(F)ST PCB	200413B000002A	Brass	Au Plated	1
3	PA.25A Antenna	001513A020007A	Ceramics	White	1
4	6.8nH Inductor (0402)	001513A000055A	Ceramics	N/A	1
5	00 Resistor (0402)	001511J010012A	Ceramics	N/A	1

7. Antenna Integration Guide

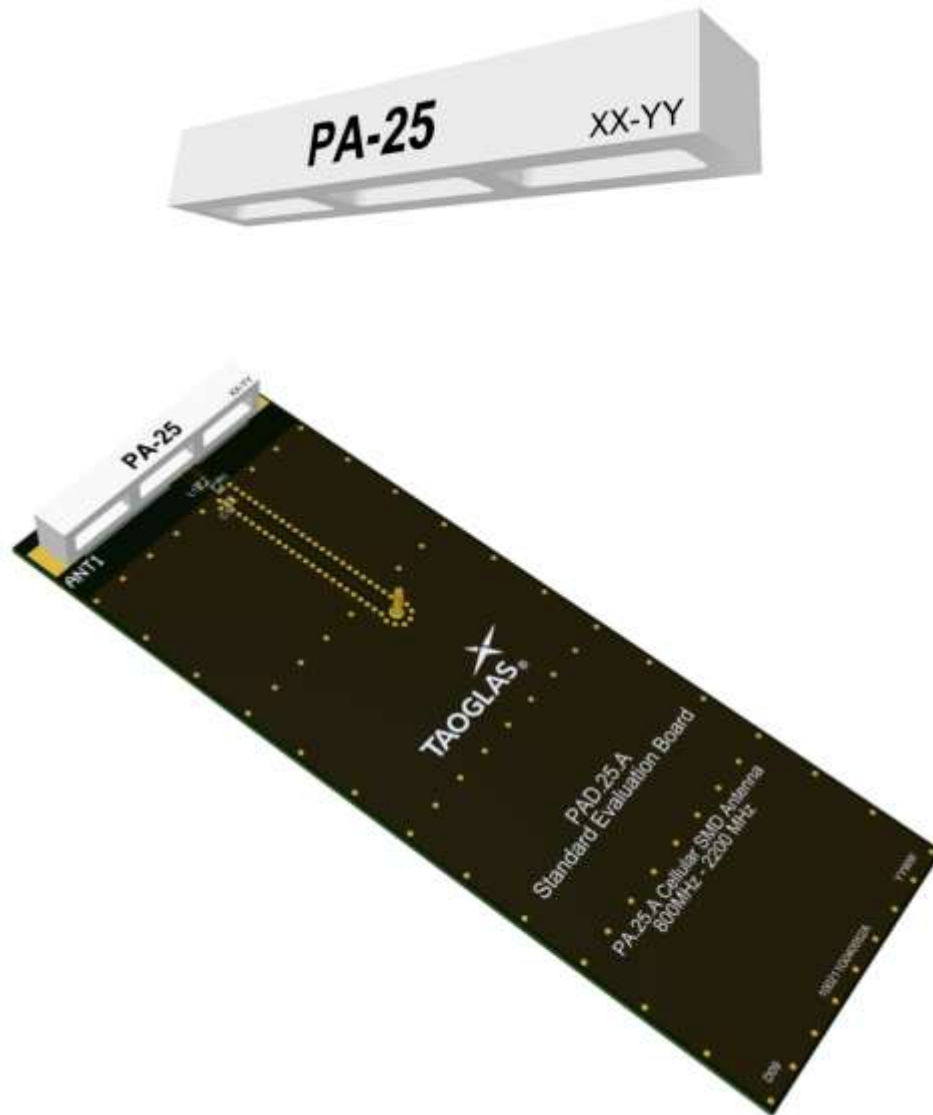

7.1 Schematic Symbol and Pin Definition

The circuit symbol for the antenna is shown below. The antenna has 4 pins with only two pins (Pin 1 and Pin 2) as functional. Pins 3 and 4 are for mechanical strength.

Pin	Description
1	RF Feed
2	Ground
3, 4	Mechanical, Not Connected

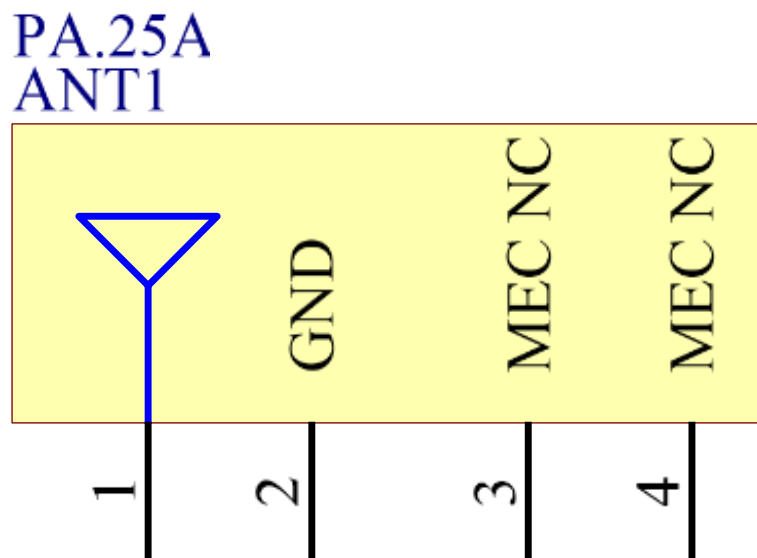

Please note you can download the design files, 3D model, 2D drawings and CST simulation files from the website here:

<https://www.taoglas.com/product/anam-pa-25a-2g3g-smd-pifa-antenna-2/>

7.2 Antenna Integration

Whatever the size of the PCB, the antenna should ideally be placed on the PCB's shortest side, to take advantage of the ground plane. Optimized matching components can be placed as shown.

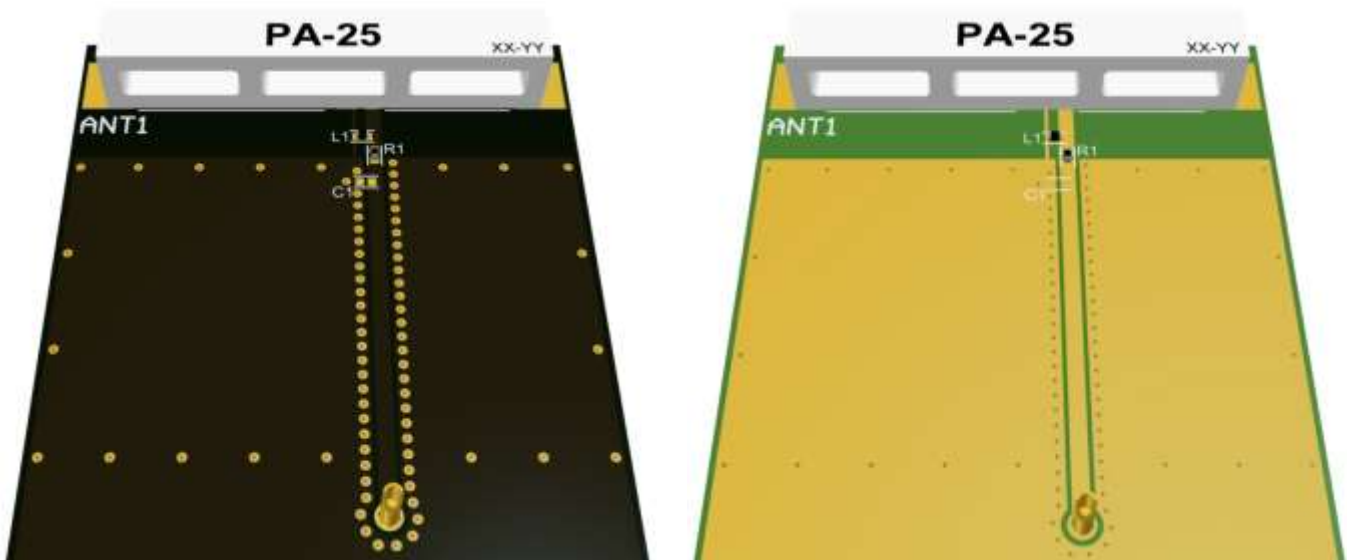

7.3 PCB Layout

The footprint and clearance on the PCB must meet the antenna specification. An example of the PCB layout shows the antenna footprint with clearance. Note the placement of the optimized components. L1 is positioned outside the ground plane and R1 is sitting across the ground plane and the copper clearance area. C1 is optional as a component but it is recommended to include these pads in case they are needed.

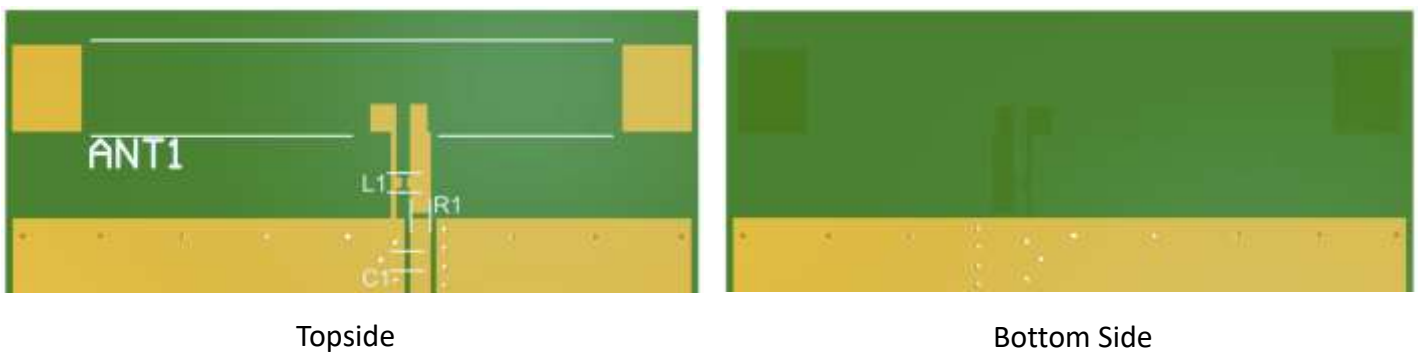

7.4 PCB Clearance

The footprint and clearance on the PCB must meet the antenna specification. An example of the PCB layout shows the antenna footprint with clearance. Note the placement of the optimized components. L1 is positioned outside the ground plane and R1 is sitting across the ground plane and the copper clearance area. C1 is optional as a component but it is recommended to include these pads in case they are needed.



Below shows the antenna footprint and clearance through ALL layers on the PCB. Only the antenna pads and connections to feed and GND are present within this clearance area (marked RED). The clearance area extends to 5mm from the antenna mechanical pads to the ground area. This clearance area includes the bottom side and ALL internal layers on the PCB.

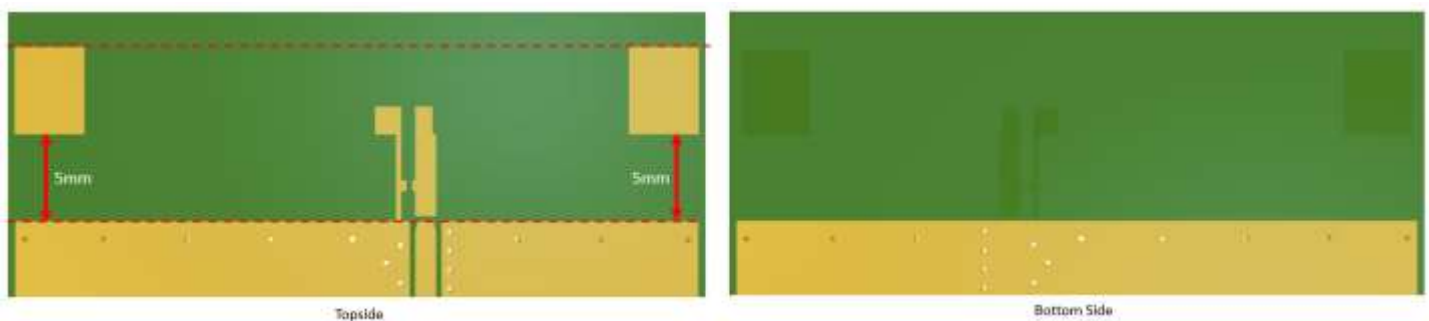

7.5 Evaluation Board



7.6 Evaluation Board Ground Plane Length



Ground Plane Length: 98mm

7.7 Evaluation Board Matching Circuit

A matching component (L1) in parallel with the PA.25A is required for the antenna to have optimal performance on the evaluation board, located outside of the ground plane in the space specified in the above images. Additional matching components may be necessary for your device, so we recommend incorporating extra component footprints, forming a “pi” network, between the cellular module and the edge of the ground plane.

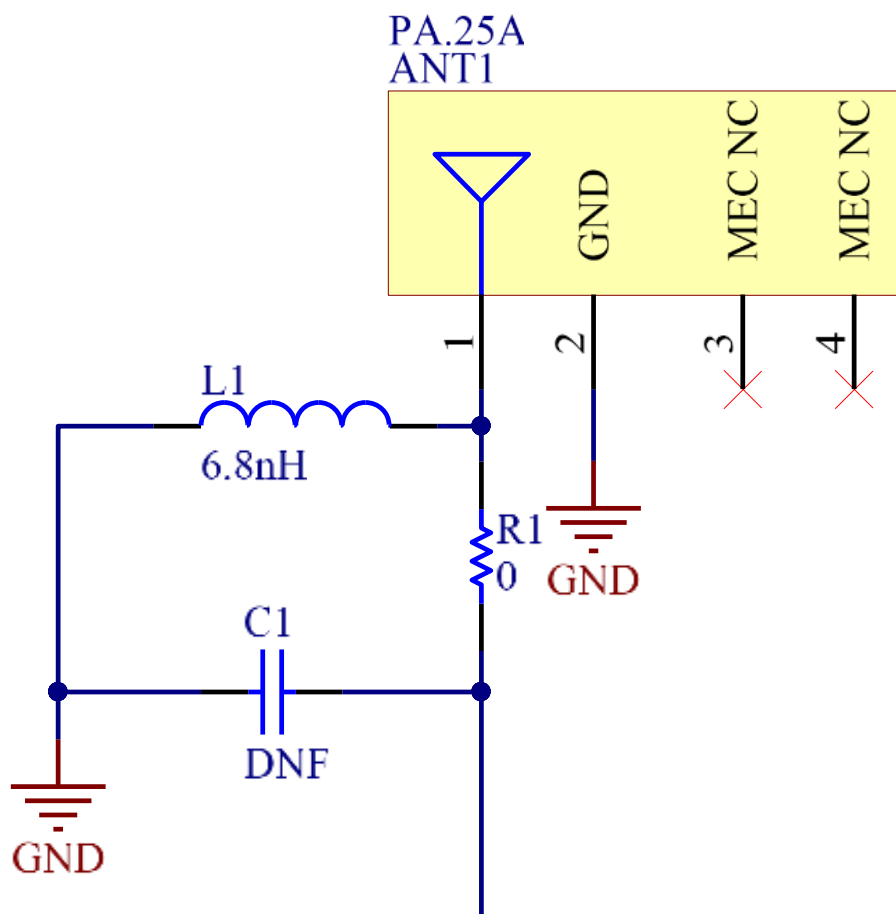

Designator	Type	Value	Manufacturer	Manufacturer Part Number
L1	Inductor	6.8nH	TDK	MLK1005S6N8DT000
R1	Resistor	0Ω	Yageo	RC0402JR-070RL
C1	Capacitor	Not Fitted	-	-

7.8 Footprint

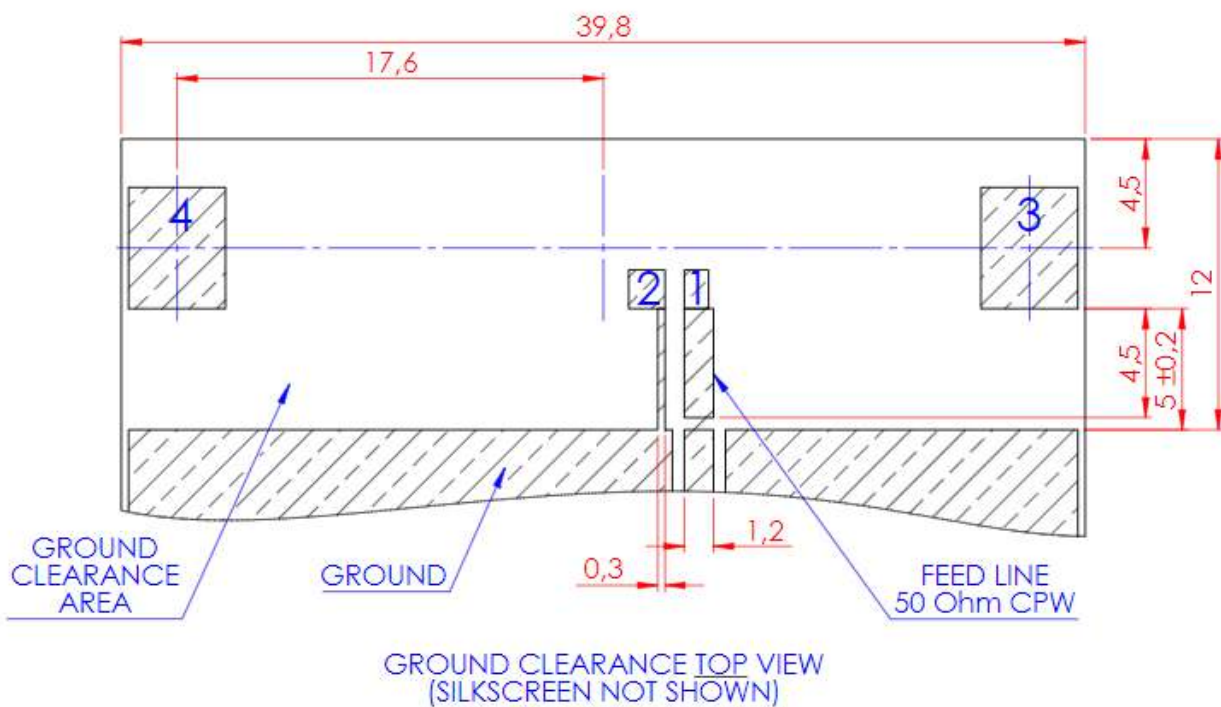
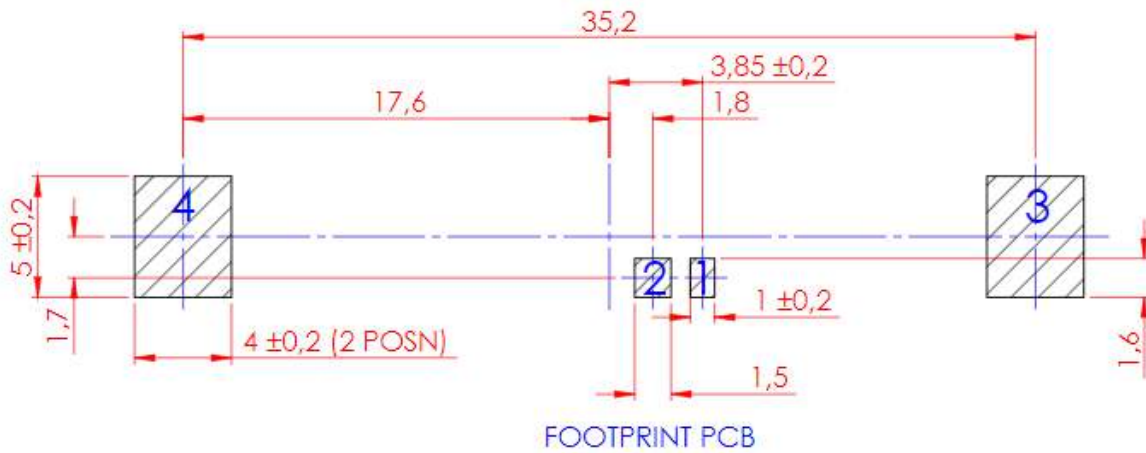

PIN:	DESCRIPTION:
1	RF FEED (50 Ohm)
2	GROUND
3,4	NOT CONNECTED

8. Recommended Reflow Temperature Profile

The PA.25 can be assembled following either Sn-Pb or Pb-Free assembly processes.

The recommended soldering temperatures are as follows:

Phase	Profile Features	Sn-Pb Assembly	Pb-Free Assembly [SnAgCu]
Ramp-Up	Avg Ramp-Up Rate [T _{smax} to T _p]	3°C/second (max)	3°C/second (max)
Preheat	Temperature Min (T _{smin}) Temperature Max (T _{smax}) Time (t _{smin} to t _{smax})	100°C 150°C 60-120 seconds	150°C 200°C 60-120 seconds
Reflow	Temperature (T _L) Total Time Above T _L b[t _L]	183°C 60-150 seconds	217°C 60-150 seconds
Peak	Temperature (T _p) Time (t _p)	235°C 10-30 seconds	260°C 20-40 seconds
Ramp-Down	Rate	6°C/second (max)	6°C/second (max)
Time from 25°C to peak Temperature		6 minutes max	8 minutes max

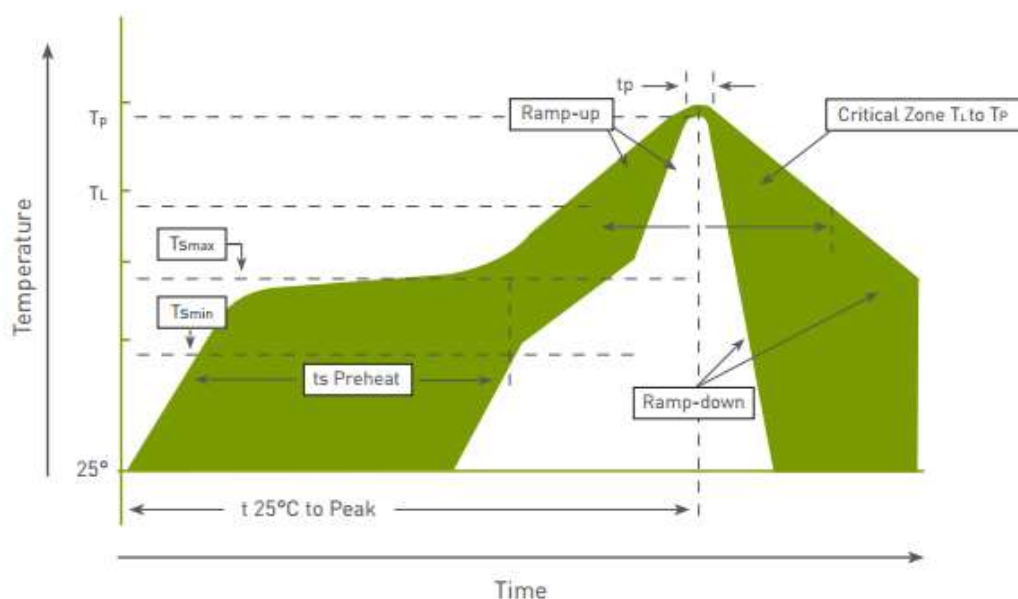

Temperature profile – (green area) for the assembly process in reflow ovens

9. Packaging (Units; mm)

450 pc PA.25.A
 1 reel per small inner box
 Dimensions - 330*55mm
 Weight - 2000g

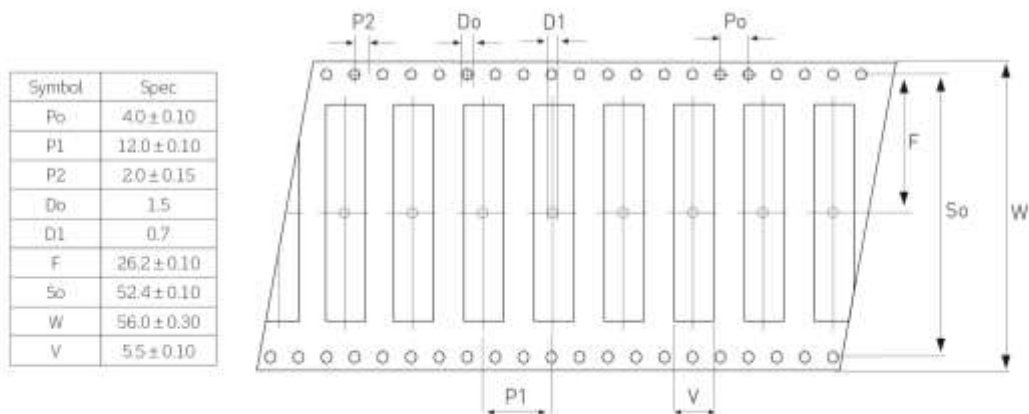
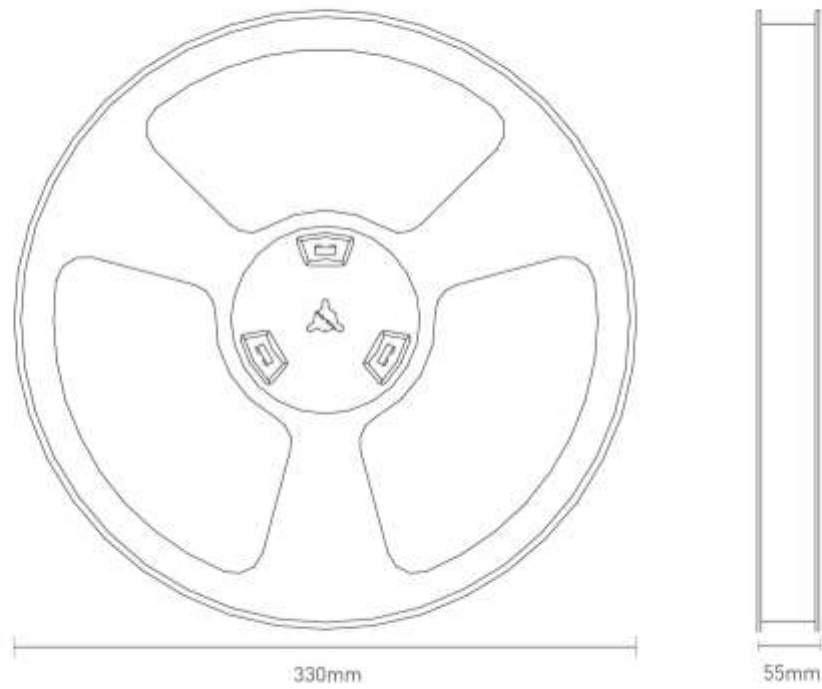

Changelog for the datasheet

SPE-11-8-061 – PA.25A

Revision: L (Current Version)

Date:	2022-02-23
Changes:	Added integration guide
Changes Made by:	Gary West

Previous Revisions

Revision: K

Date:	2020-11-10
Changes:	Specifications table amended - Moisture Sensitivity Level 3
Changes Made by:	Dan Cantwell

Revision: F

Date:	2013-03-21
Changes:	
Changes Made by:	Technical Writer

Revision: J

Date:	2016-12-21
Changes:	
Changes Made by:	Technical Writer

Revision: E

Date:	2012-12-06
Changes:	
Changes Made by:	Technical Writer

Revision: I

Date:	2016-09-22
Changes:	Updated PAD, EBV drawing and image
Changes Made by:	Andy Mahoney

Revision: D

Date:	2011-09-07
Changes:	
Changes Made by:	Technical Writer

Revision: H

Date:	2016-01-18
Changes:	
Changes Made by:	Technical Writer

Revision: C

Date:	
Changes:	
Changes Made by:	Technical Writer

Revision: G

Date:	2013-09-03
Changes:	Amended Dimensions
Changes Made by:	Aine Doyle

Revision: B

Date:	
Changes:	
Changes Made by:	Technical Writer

Revision: A (Original First Release)

Date: 2010-08-18

Notes:

Author: Technical Writer



TAOGLAS®

www.taoglas.com

