

THIS DRAWING IS UNPUBLISHED. RELEASED FOR PUBLICATION 20  
 © COPYRIGHT 20 BY TYCO ELECTRONICS CORPORATION. ALL RIGHTS RESERVED.

LOC	DIST	REVISIONS			
P	LTR	DESCRIPTION	DATE	DWN	APVD
CE	00	A	RELEASE TO ACTIVE	06JUN2006	BB SM

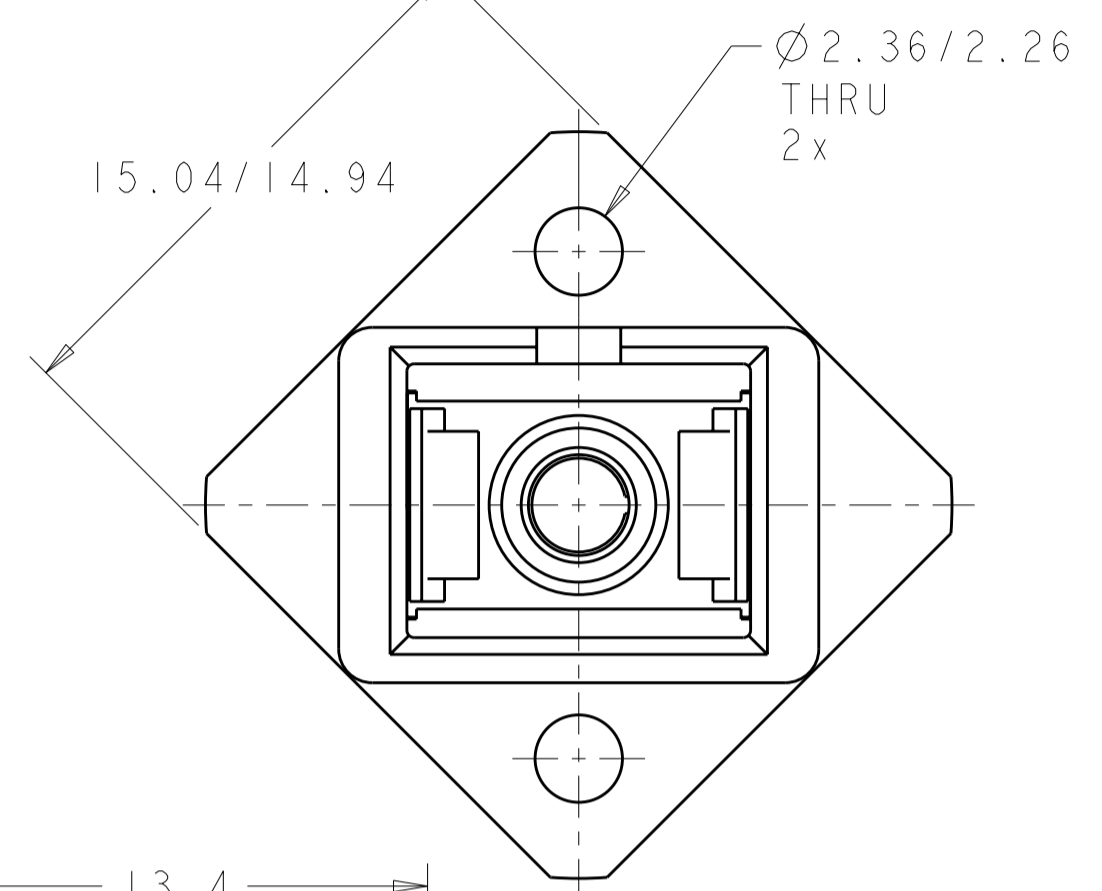

⚠ MATERIAL:  
 BODY: ZINC DIECAST, NICKEL PLATED  
 ALIGNMENT SLEEVE: SEE DASH NUMBERS  
 PROTECTIVE COVER: TPE, COLOR: BLACK\*  
 RETAINER: PEI-GF30, COLOR: BLACK\*  
 \*UL94 V-0 RATED AT QUALIFYING THICKNESS.

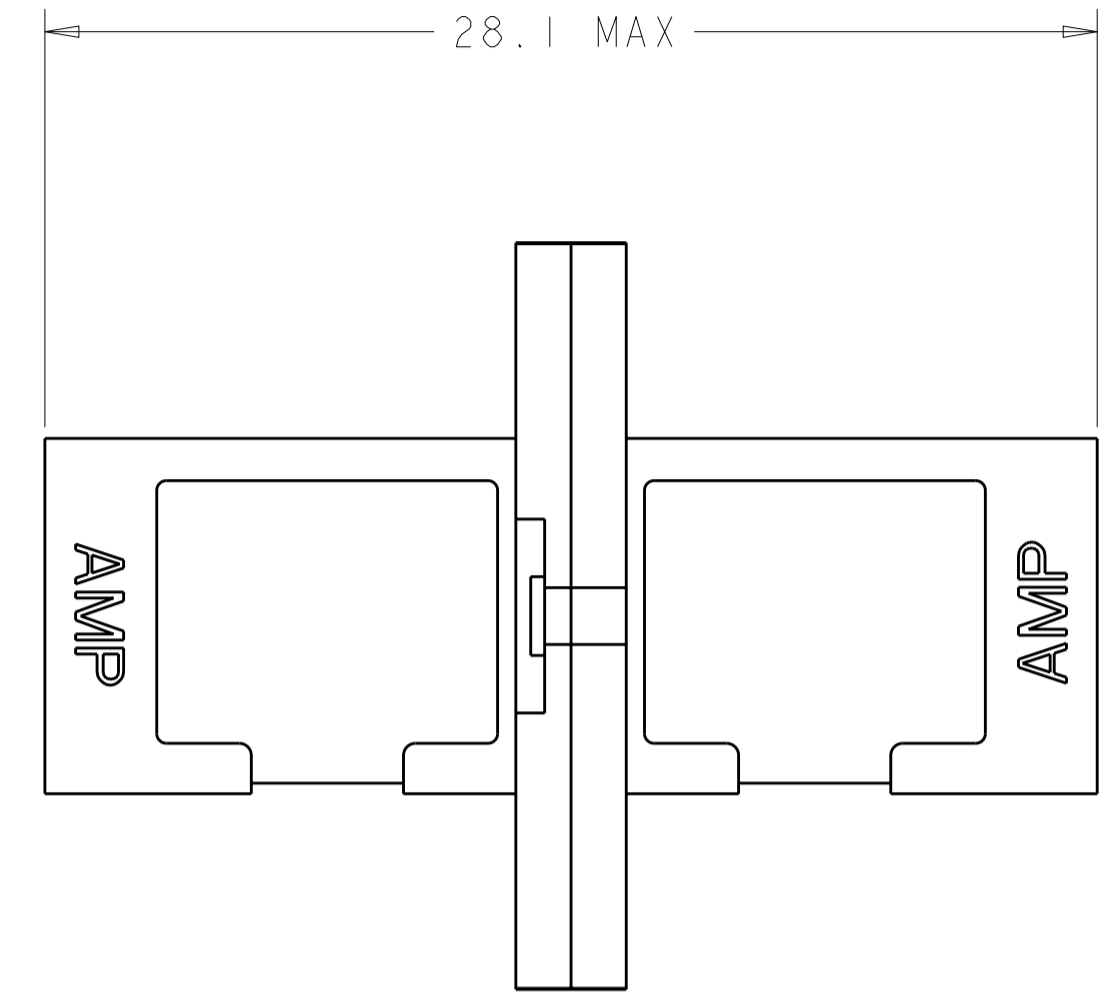
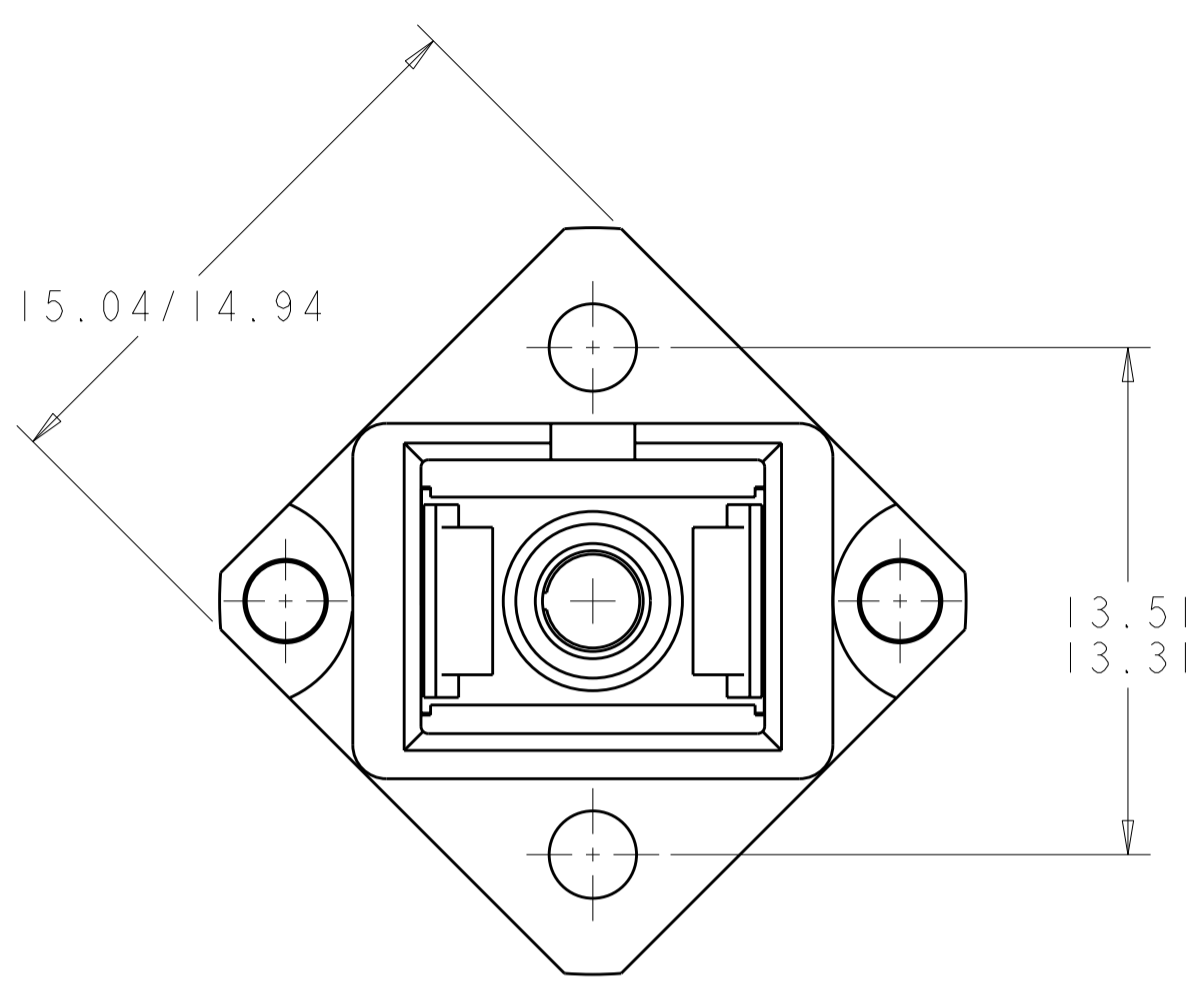
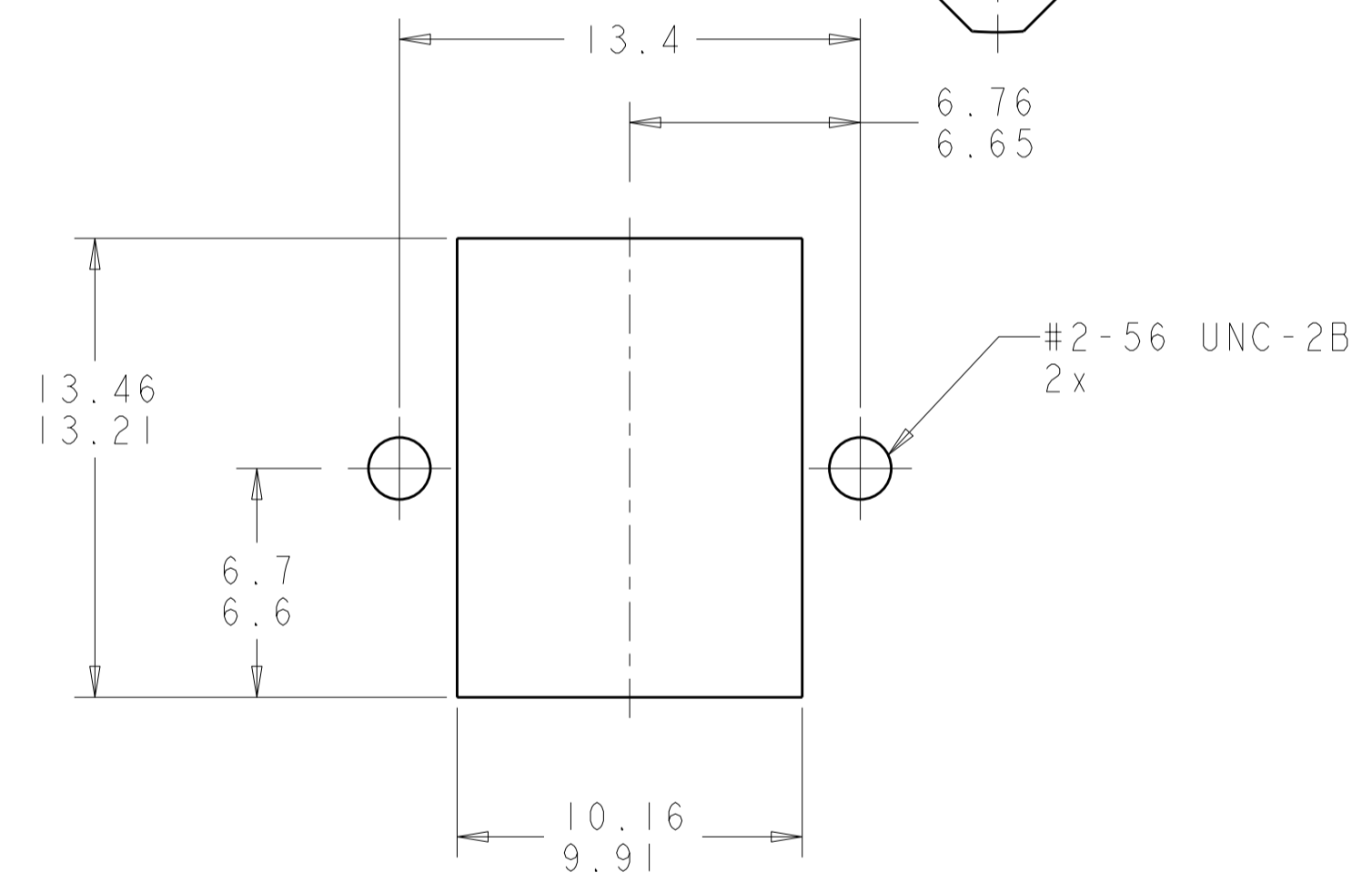
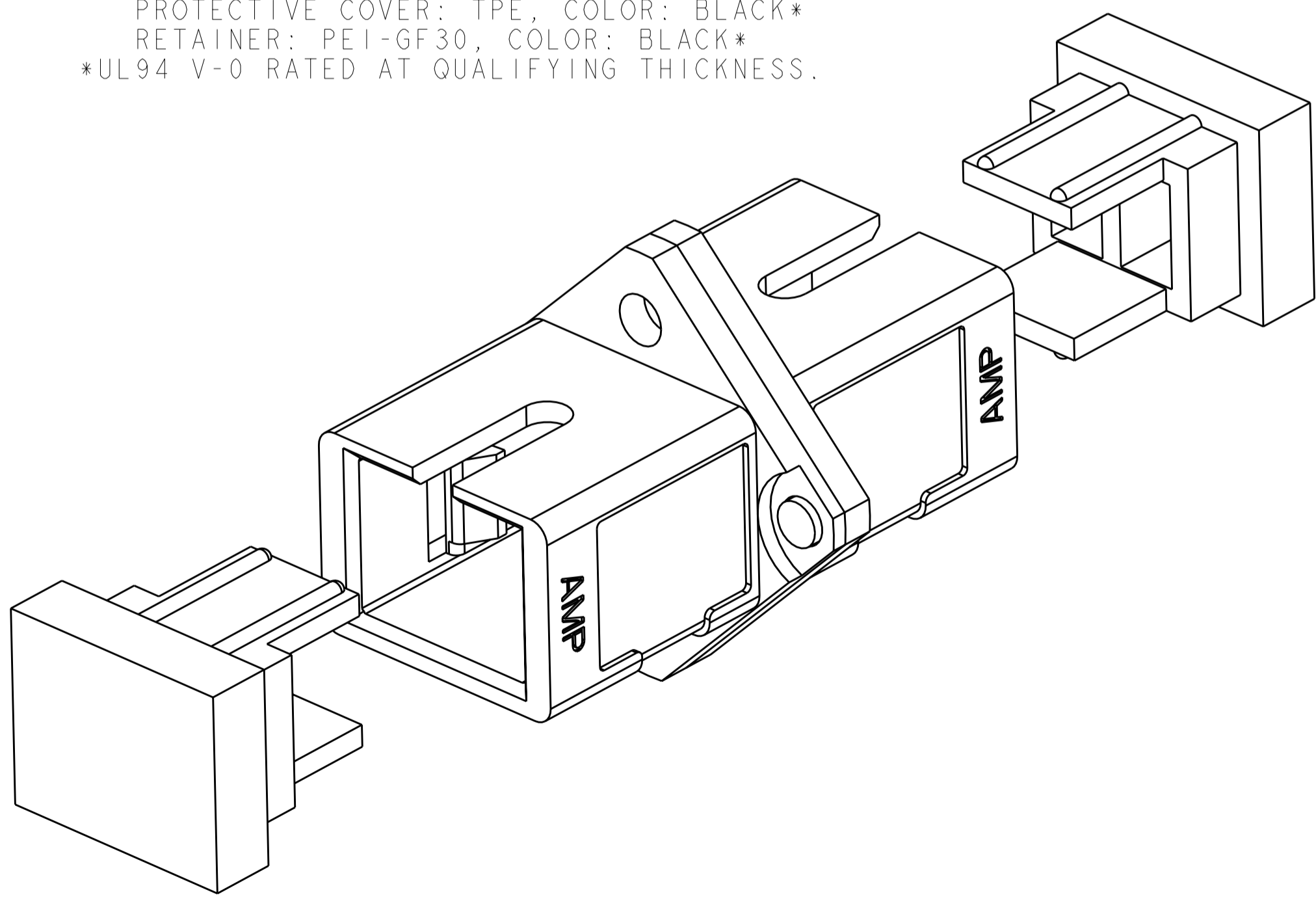

RECOMMENDED MOUNTING PATTERN

CERAMIC	5492051-2
METAL	5492051-1
ALIGNMENT SLEEVE MATERIAL	PART NUMBER

THIS DRAWING IS A CONTROLLED DOCUMENT FOR TYCO ELECTRONICS CORPORATION. IT IS SUBJECT TO CHANGE AND THE CONTROLLING ENGINEERING ORGANIZATION SHOULD BE CONTACTED FOR THE LATEST REVISION.		DWN B. BRIGGS 03JUN2005	Tyco Electronics Harrisburg, PA 17105-3608
DIMENSIONS:		CHK S. MILLER 03JUN2005	
TOLERANCES UNLESS OTHERWISE SPECIFIED:		APVD S. BUCHTER 03JUN2005	
mm		PRODUCT SPEC	
0 PLC ± 1 PLC ± 2 PLC ± 3 PLC ± 4 PLC ± ANGLES ± FINISH		APPLICATION SPEC	NAME AMP SC TO SC COUPLING RECEPTACLE, METAL
MATERIAL		WEIGHT	SIZE CAGE CODE DRAWING NO RESTRICTED TO
		-	A200779C-5492051
CUSTOMER DRAWING		SCALE 5:1	SHEET 1 OF 1 REV A