



## Features

- ESD Protect for 2 high-speed I/O channels
- Provide ESD protection for each channel to IEC 61000-4-2, (ESD)  $\pm 15\text{kV}$  (air),  $\pm 10\text{kV}$  (contact)
- For operating voltage of 5V and below
- Ultra low capacitance: 0.5pF typical
- Fast turn-on and Low clamping voltage
- Array of ESD rated diodes with internal equivalent TVS diode
- Solid-state silicon-avalanche and active circuit triggering technology
- Simplified layout for high-speed differential signaling channels
- **Green part**

## Applications

- MHL (Mobile High-Definition Link)
- USB 3.0 and USB 2.0
- HDMI 1.4 and HDMI 1.3
- DisplayPort interface
- SATA and eSATA interface
- Mobile Phones
- Hand Held Portable Applications

## Description

AZ1045-02F is a design which includes ESD rated diode arrays to protect high speed data interfaces. The AZ1045-02F has been specifically designed to protect sensitive components which are connected to data and transmission lines from over-voltage caused by Electrostatic Discharging (ESD).

AZ1045-02F is a unique design which includes ESD rated, ultra low capacitance steering diodes and a unique design of clamping cell which is an equivalent TVS diode in a single package. During transient conditions, the steering diodes direct the transient to either the internal ESD line or to ground line. The internal unique design of clamping cell prevents over-voltage on the internal ESD line and on the I/O line, which is protecting any downstream components.

AZ1045-02F may be used to meet the ESD immunity requirements of IEC 61000-4-2, Level 4 ( $\pm 15\text{kV}$  air,  $\pm 8\text{kV}$  contact discharge).

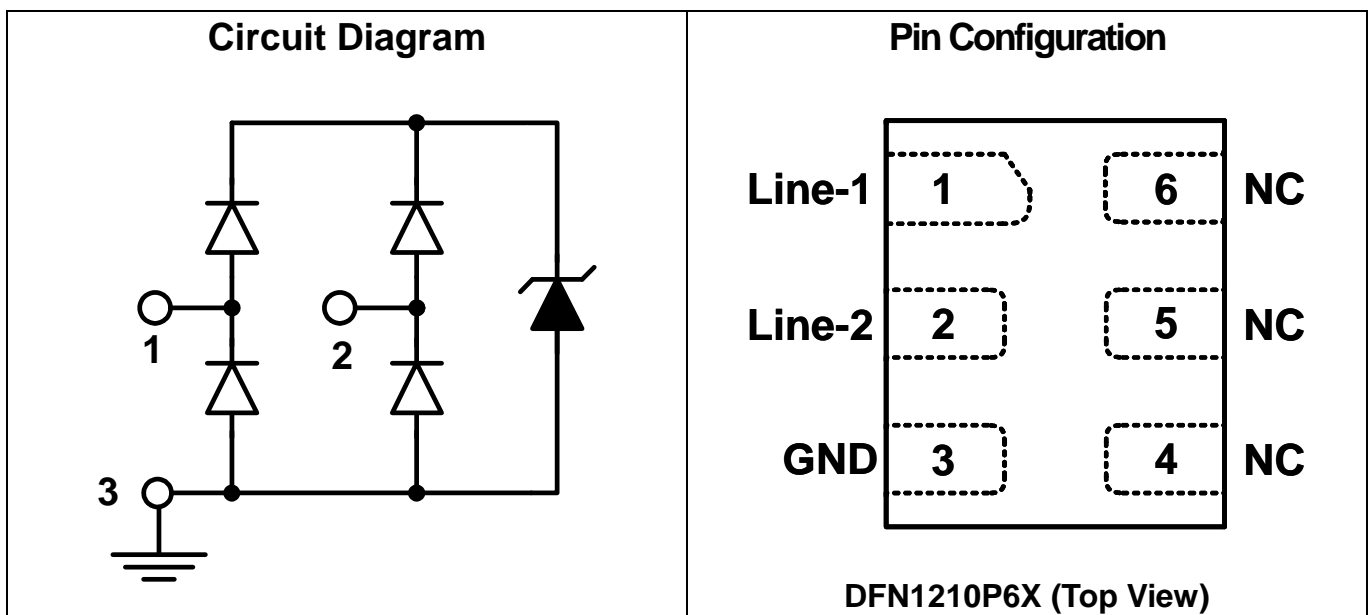



## SPECIFICATIONS

ABSOLUTE MAXIMUM RATINGS			
PARAMETER	PARAMETER	RATING	UNITS
Peak Pulse Current (tp= 8/20μs)	$I_{pp}$	3.5	A
Operating Voltage (I/O pin-GND)	$V_{DC}$	5.5	V
ESD per IEC 61000-4-2 (Air)	$V_{ESD}$	±15	kV
ESD per IEC 61000-4-2 (Contact)		±10	
Lead Soldering Temperature	$T_{SOL}$	260 (10 sec.)	°C
Operating Temperature	$T_{OP}$	-55 to +85	°C
Storage Temperature	$T_{STO}$	-55 to +150	°C

ELECTRICAL CHARACTERISTICS						
PARAMETER	SYMBOL	CONDITIONS	MIN	TYP	MAX	UNITS
Reverse Stand-Off Voltage	$V_{RWM}$	Pin-1,-2 to pin-3, T=25 °C.			5	V
Channel Leakage Current	$I_{CH-Leak}$	$V_{Pin-1,-2} = 5V, V_{Pin-3} = 0V, T=25 °C.$			1.5	μA
Reverse Breakdown Voltage	$V_{BV}$	$I_{BV} = 1mA, T=25 °C, Pin-1,-2 to pin-3.$	6			V
Forward Voltage	$V_F$	$I_F = 15mA, T=25 °C, Pin-3 to pin-1,-2.$		0.9	1.1	V
ESD Clamping Voltage	$V_{clamp}$	IEC 61000-4-2 +6kV, T=25 °C, Contact mode, any I/O pin to Ground.		12		V
ESD Dynamic Turn-on Resistance	$R_{dynamic}$	IEC 61000-4-2, 0~+6kV, T=25 °C, Contact mode, any I/O pin to Ground.		0.3		Ω
Channel Input Capacitance	$C_{IN}$	$V_{Pin-3} = 0V, V_{IN} = 2.5V, f = 1MHz, T=25 °C, any I/O pin to Ground.$		0.5	0.65	pF
Channel to Channel Input Capacitance	$C_{CROSS}$	$V_{Pin-3} = 0V, V_{IN} = 2.5V, f = 1MHz, T=25 °C, between I/O pins.$		0.04	0.08	pF



## Typical Characteristics

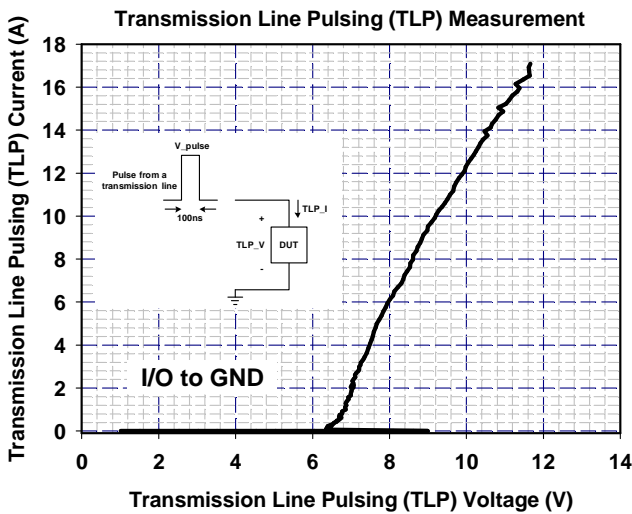
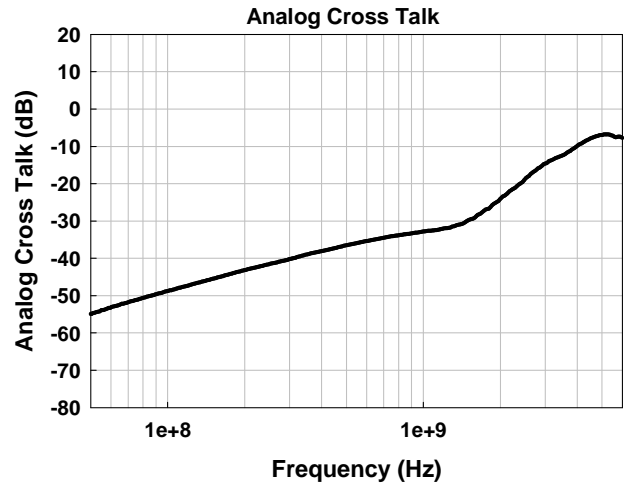
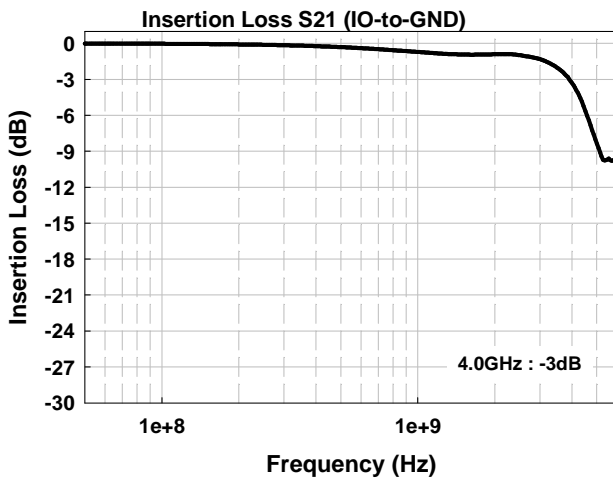
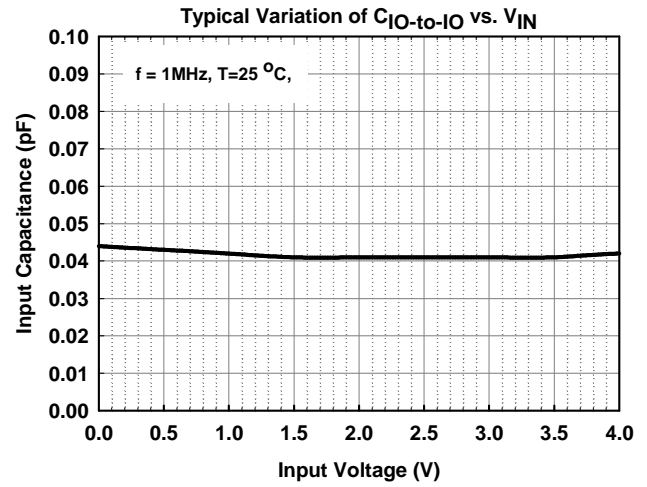
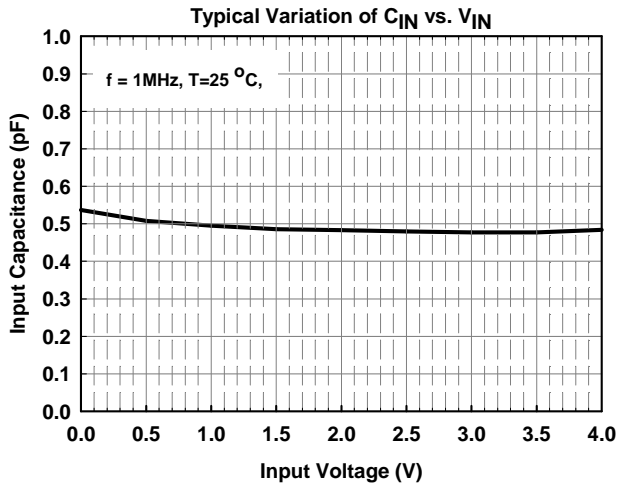

## Applications Information

### A. Device Connection

The AZ1045-02F is designed to protect two data lines from transient over-voltage (such as ESD stress pulse). The device connection of AZ1045-02F is shown in the Fig. 1. In Fig. 1, the two protected data lines are connected to the ESD protection pins (pin1, pin2) of AZ1045-02F. The ground pin (pin3) of AZ1045-02F is a

negative reference pin. This pin should be directly connected to the GND rail of PCB (Printed Circuit Board). To get minimum parasitic inductance, the path length should keep as short as possible.

AZ1045-02F can provide protection for 2 I/O signal lines simultaneously. If the number of I/O signal lines is less than 2, the unused I/O pins can be simply left as NC pins.

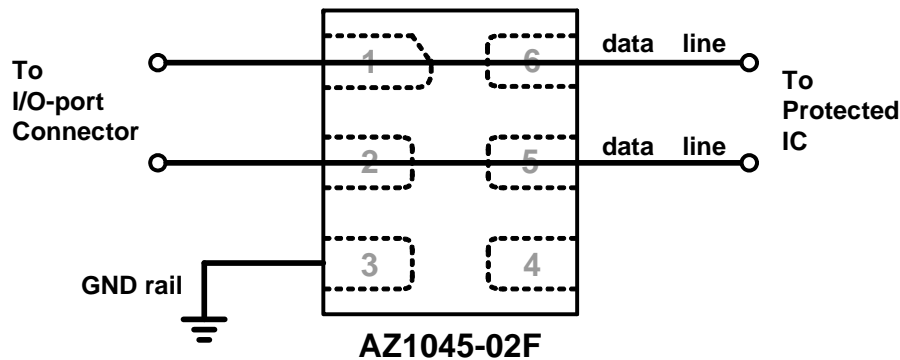

Fig. 1 Data lines connection of AZ1045-02F.

### B. Application

AZ1045-02F is designed for protecting high speed I/O ports from over-voltage caused by Electrostatic Discharging (ESD). Thus, a lot of kinds of high speed I/O ports can be the applications of AZ1045-02F. Fig. 2 shows MHL

ESD protection by using AZ1045-02F. The AZ1045-02F is designed for allowing the traces to run straight through the device to simplify the PCB layout. The best way to design the PCB trace is using the flow through layout.

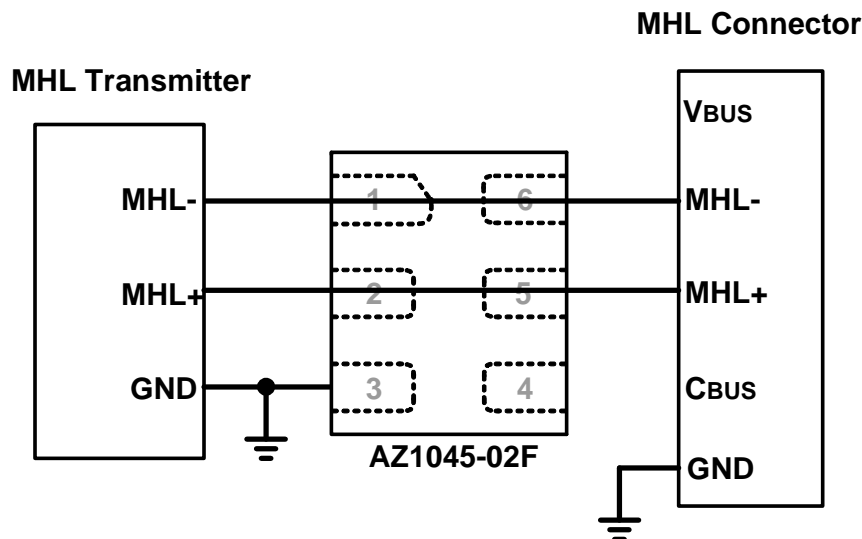
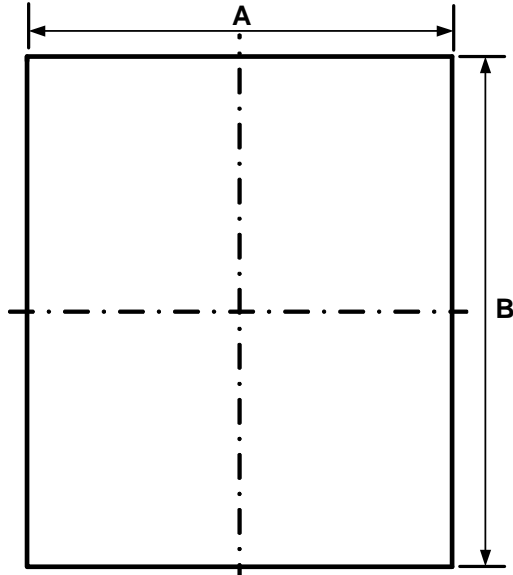

Fig. 2 MHL ESD Protection by using AZ1045-02F.



## Mechanical Details

### DFN1210P6X PACKAGE DIAGRAMS AND DIMENSIONS



TOP VIEW

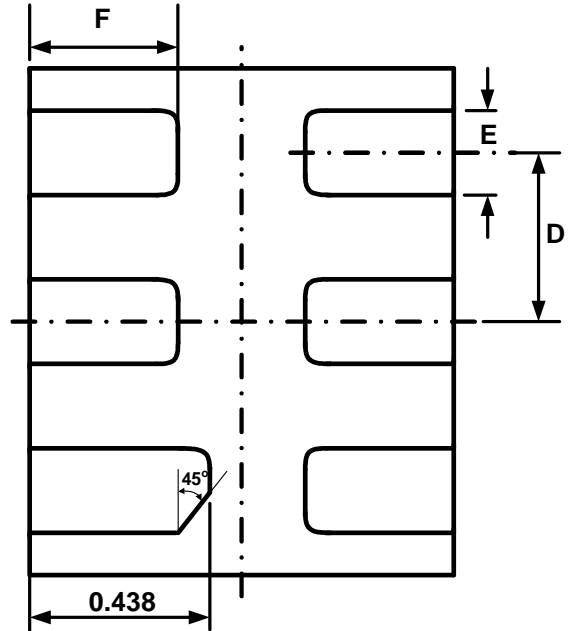

BOTTOM VIEW (unit in mm)

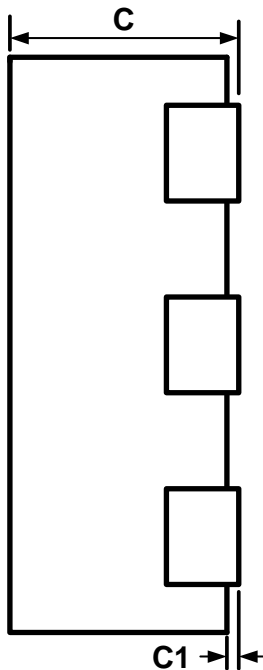

SIDE VIEW

SYMBOL	Millimeters		
	MIN.	NOM.	MAX.
A	0.95	1.00	1.05
B	1.15	1.20	1.25
C	0.41	0.45	0.50
C1	0.00	0.02	0.05
D	0.40		
E	0.15	0.20	0.25
F	0.25	0.35	0.45



## LAND LAYOUT

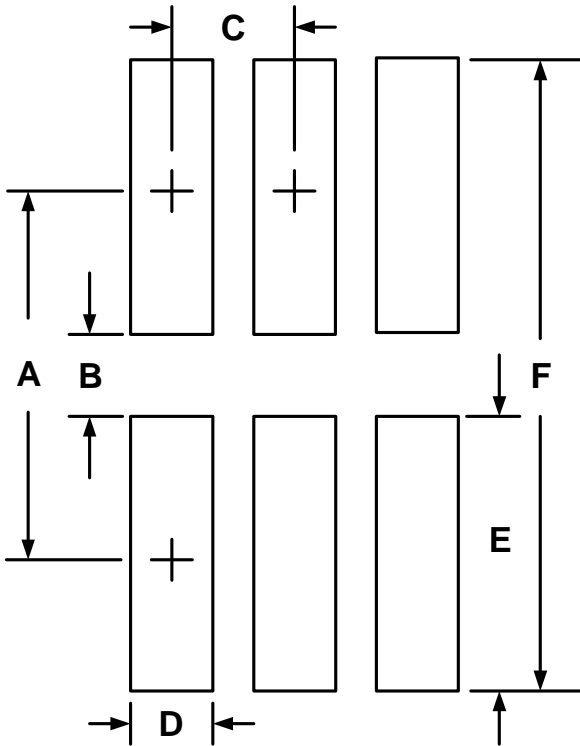

Dimensions		
Index	Millimeter	Inches
A	0.875	0.034
B	0.20	0.008
C	0.40	0.016
D	0.20	0.008
E	0.675	0.027
F	1.55	0.061

### Notes:

This LAND LAYOUT is for reference purposes only. Please consult your manufacturing partners to ensure your company's PCB design guidelines are met.

## MARKING CODE

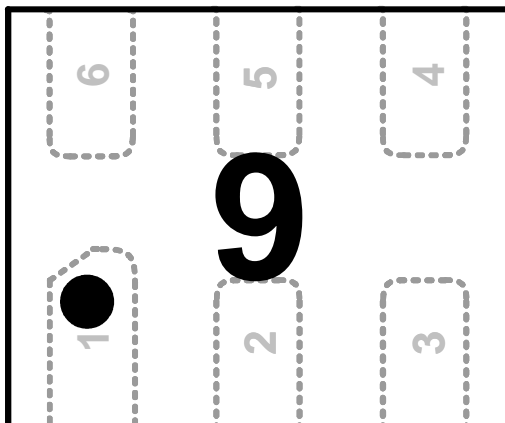

Part Number	Marking Code
AZ1045-02F	9



## Ordering Information

PN#	Material	Type	Reel size	MOQ/internal box	MOQ/carton
AZ1045-02F.R7G	Green	T/R	7 inch	4 reel= 12,000/box	6 box =72,000/carton

## Revision History

Revision	Modification Description
Revision 2011/12/13	Formal Release.