

# AMR2501

## High Accuracy, Low Noise Linear Magnetic Sensor

### Description

The AMR2501 linear sensor utilizes a push-pull Wheatstone bridge composed of four highly sensitive AMR sensor elements. The Wheatstone bridge effectively compensates the sensor's temperature drift to achieve outstanding temperature stability with minimal noise. AMR2501 is available in the DFN16L package.

### Features and Benefits

- Anisotropic magnetoresistance (AMR) technology
- Low noise density: 100 pT/ $\sqrt{\text{Hz}}$ @1 Hz
- Wide range supply voltages
- Low saturation field
- Excellent temperature stability
- Low hysteresis

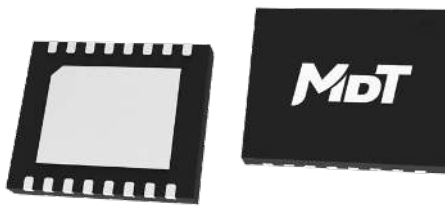

DFN16L (5 mm × 6 mm × 0.75 mm)

### Applications

- Weak magnetic field sensing
- Current sensor
- Position sensor
- Magnetometer

### Selection Guide

Part Number	Linear Range	Sensitivity	Set/reset Coil Resistance	Offset Coil Resistance	Noise Density	Package	Packing Form
AMR2501D-A	±1 Gs	2.5 mV/V/Gs	2 Ω	3 Ω	100 pT/ $\sqrt{\text{Hz}}$	DFN16L	Tape & Reel
AMR2501D-B	±1 Gs	2.5 mV/V/Gs	2 Ω	40 Ω	100 pT/ $\sqrt{\text{Hz}}$	DFN16L	Tape & Reel

## Catalogue

1. Functional Block Diagram.....	03
2. Sensing Direction .....	03
3. Pin Configuration .....	03
4. Absolute Maximum Ratings .....	04
5. Electrical Specifications.....	04
6. Typical Output Characteristics.....	05
7. Application Information .....	06
8. Dimensions.....	07

### 1. Functional Block Diagram

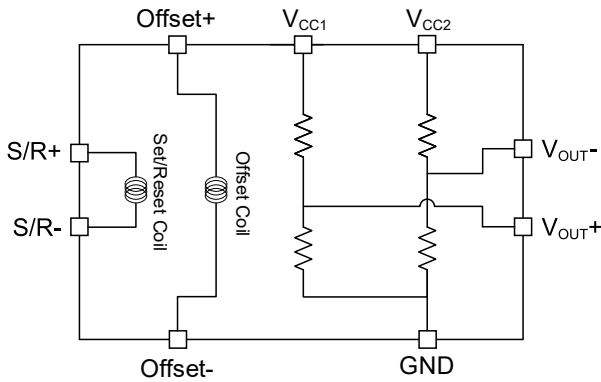

Figure 1. Block Diagram

### 2. Sensing Direction

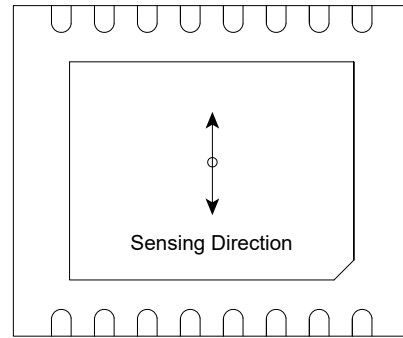

Figure 2. Sensing Direction (DFN16L)

### 3. Pin Configuration

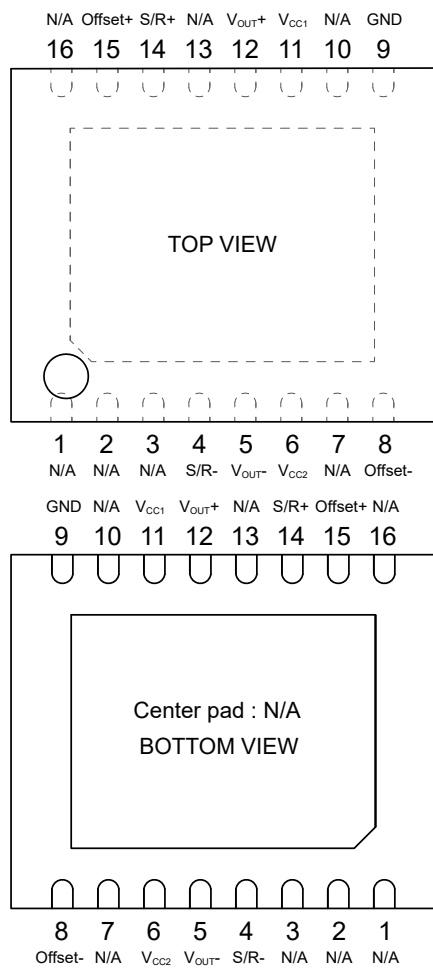

Figure 3. Pin Configuration (DFN16L)

Pin Number	Name	Function
1	N/A	Not connected
2	N/A	Not connected
3	N/A	Not connected
4	S/R-	Set/reset input -
5	V <sub>OUT-</sub>	Output -
6	V <sub>CC2</sub>	Supply voltage
7	N/A	Not connected
8	Offset-	Offset voltage -
9	GND	Ground
10	N/A	Not connected
11	V <sub>CC1</sub>	Supply voltage
12	V <sub>OUT+</sub>	Output +
13	N/A	Not connected
14	S/R+	Set/reset input +
15	Offset+	Offset voltage +
16	N/A	Not connected

## 4. Absolute Maximum Ratings

Parameters	Symbol	Min.	Max.	Unit
Supply Voltage	$V_{CC}$	-	12	V
ESD Performance (HBM)	$V_{ESD}$	-	4	kV
Operating Ambient Temperature	$T_A$	-55	150	°C
Storage Ambient Temperature	$T_{STG}$	-55	175	°C
Soldering Temperature	$T_I$	-	260	°C
Magnetic Field	B	-	10000	Gs

## 5. Electrical Specifications

$V_{CC} = 5.0$  V,  $T_A = 25$  °C,  $I_{S/R} = 2.5$  A, differential output unless otherwise specified

Parameter	Symbol	Condition	Min.	Typ.	Max.	Unit	
Supply Voltage	$V_{CC}$	Bridge voltage, referenced to ground	1.8	5	12	V	
Bridge Resistance	$R_B$	$I = 10$ mA	500	700	1100	$\Omega$	
Field Range	$B_{SAT}$	Full scale (FS)	-2	-	2	Gs	
Linearity Error	NONL	Fit in: $\pm 1$ Gs	-	0.2	0.5	%FS	
		Fit in: $\pm 2$ Gs	-	1.2	2		
Hysteresis Error	HYS	2 sweeps, across $\pm 2$ Gs	-	0.02	0.1	%FS	
Repeatability Error	$B_{repeat}$	2 sweeps, across $\pm 2$ Gs	-	0.05	0.1	%FS	
Bridge Offset	$V_{OFFSET}$	$V_{OFFSET} = (V_{OUT+}) - (V_{OUT-})$ , B = 0 Gs, after set pulse	-10	$\pm 2$	+10	mV/V	
Sensitivity	SEN	-	1.8	2.5	3.5	mV/V/Gs	
Voltage Noise Density	$V_{noise}$	At 1 Hz	-	20	-	nV/ $\sqrt{Hz}$	
Magnetic Noise Density	$B_{noise}$	At 1 Hz	-	100	-	pT/ $\sqrt{Hz}$	
Resolution	RES	Bandwidth = 10 Hz	-	20	-	$\mu$ Gs	
Bandwidth	BW	Magnetic signal (lower limit = DC)	-	5	-	MHz	
Offset Coil Resistance	$R_{OFFCOIL}$	Measured from OFFSET+ to OFFSET-	AMR2501D-A	-	3	-	$\Omega$
			AMR2501D-B	-	40	-	
Offset Field	$B_{OFFCOIL}$	Field applied in sensitive direction	AMR2501D-A	45	51	60	mA/Gs
			AMR2501D-B	9	10	12	
Set/Reset Coil Resistance	$R_{S/R}$	Measured between S/R+ and S/R-	1.5	2	2.5	$\Omega$	
Set/Reset Current	$I_{S/R}$	2 $\mu$ s current pulse	1	2.5	3.5	A	
Disturbing Field	$B_{disturb}$	Sensitivity starts to degrade, restore by S/R pulse	-	3	-	Gs	
Sensitivity Temperature Coefficient	TCS	$T_A = -40$ °C to 125 °C	-	-3000	-	PPM/°C	
Bridge Offset Temperature Coefficient	TCO	$T_A = -40$ °C to 125 °C, w/o set/reset	-	300	-	PPM/°C	
		$T_A = -40$ °C to 125 °C, w/ set/reset	-	10	-		
Resistance Temperature Coefficient	TCR	$T_A = -40$ °C to 125 °C	-	2500	-	PPM/°C	
Cross-Axis Effect	$X_B$	Cross field = 1 Gs	-	$\pm 0.5$	-	%FS	

## 6. Typical Output Characteristics

Figure 4 shows the response of the AMR2501 to an applied magnetic field. (Applied field =  $\pm 6$  Gs, analysis field =  $\pm 2$  Gs, and  $V_{CC} = 5$  V).

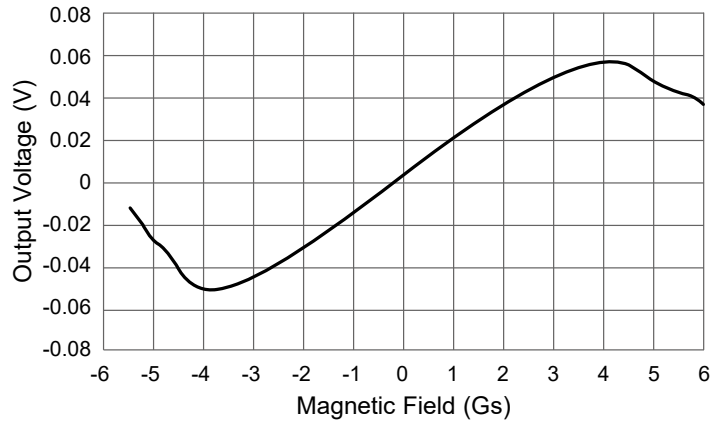

Figure 4. AMR2501 output vs. applied field

Typical voltage noise density

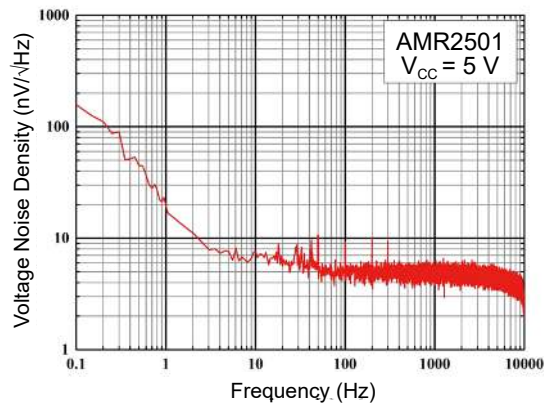

Figure 5. AMR2501 voltage noise density vs. frequency

Typical magnetic noise density

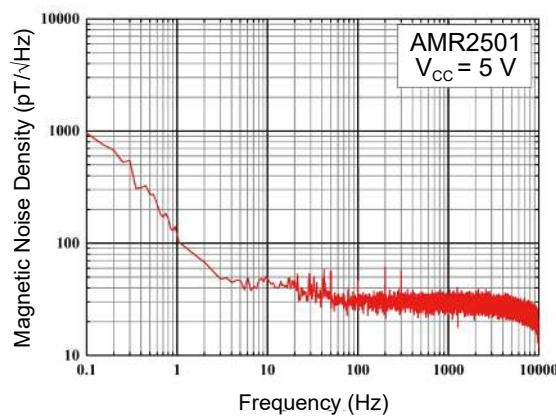

Figure 6. AMR2501 magnetic noise density vs. frequency

## 7. Application Information

A voltage pulse of 5 V for 2  $\mu$ s in 10 kHz can be select as the set/reset signal. The pulse voltage, pulse width and duty cycle can be adjusted in a certain range. A typical drive circuit is shown in Figure 7.

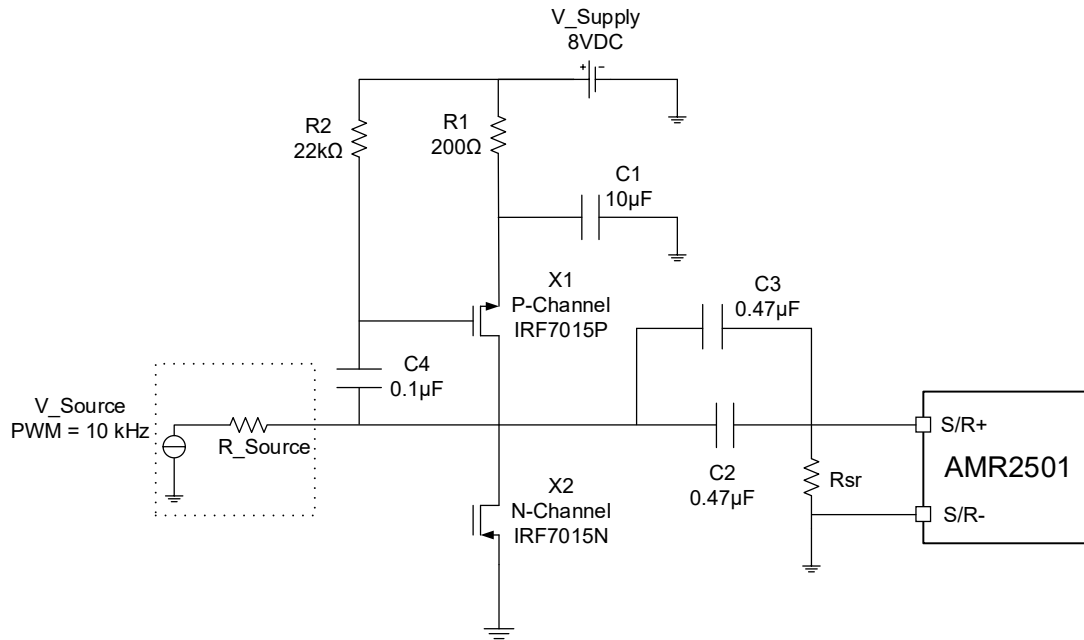

Figure 7. Set/reset drive circuit of AMR2501

The circuit will generate 5 V set/reset pulses, as illustrated in figure 8.

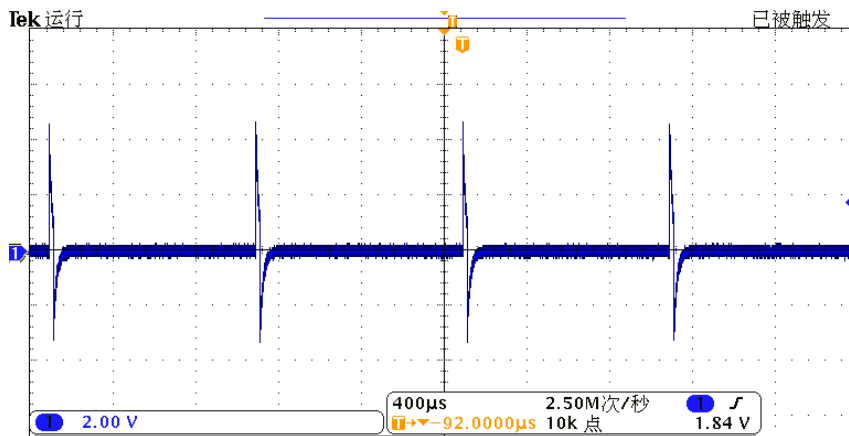

Figure 8. Set/reset voltage pulses waveform

When set-only or reset-only pulse is applied, the set- and reset- pulse is switchable by reversing the set/reset input.

## 8. Dimensions

### DFN16L Package

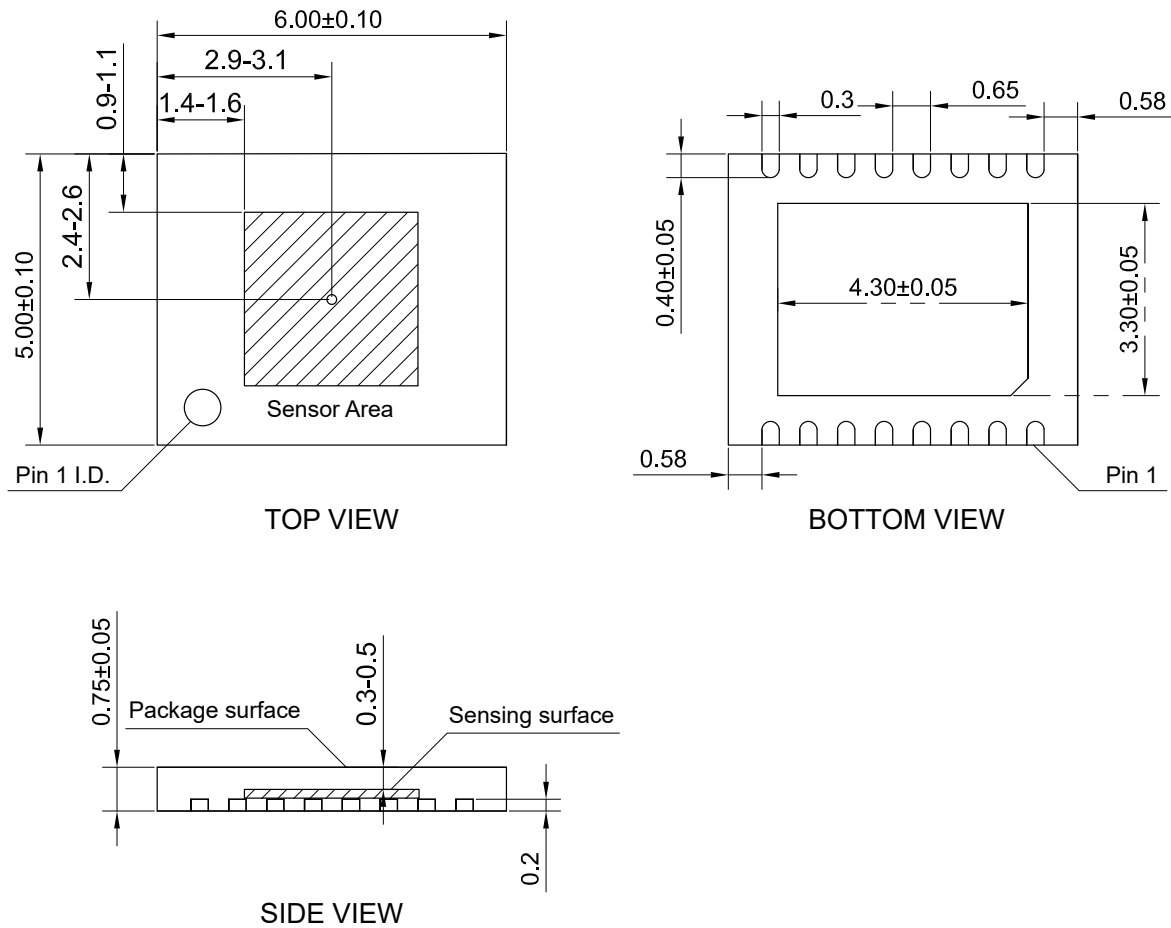

Figure 9. Package outline of DFN16L (unit: mm)

## Copyright © 2022 by MultiDimension Technology Co., Ltd.

Information furnished herein by MultiDimension Technology Co., Ltd. (hereinafter MDT) is believed to be accurate and reliable. However, MDT disclaims any and all warranties and liabilities of any kind, with respect to any examples, hints or any performance or use of technical data as described herein and/or any information regarding the application of the product, including without limitation warranties of non-infringement of intellectual property rights of any third party. This document neither conveys nor implies any license under patent or other industrial or intellectual property rights. Customer or any third-party must further determine the suitability of the MDT products for its applications to avoid the applications default of customer or third-party. MDT accept no liability in this respect.

MDT does not assume any liabilities of any indirect, incidental, punitive, special or consequential damages (including without limitation of lost profits, lost savings, business interruption, costs related to the removal or replacement of any products or rework charges) whether or not such damages are based on tort (including negligence), warranty, breach of contract or any other legal theory. Notwithstanding any damages that customer might incur for any reason whatsoever, MDT's aggregate and cumulative liability towards customer for the products described herein shall be limited in accordance with the terms and conditions of commercial sale of MDT.

Absolute maximum ratings are the extreme limits the device will withstand without damage to the MDT product. However, the electrical and mechanical characteristics are not guaranteed as the maximum limits (above recommended operating conditions) are approached. MDT disclaims any and all warranties and liabilities of the MDT product will operate at absolute maximum ratings.

Specifications may change without notice.

Please download latest document from our official website [www.dowaytech.com/en](http://www.dowaytech.com/en).

## Recycling

The product(s) in this document need to be handed over to a qualified solid waste management services company for recycling in accordance with relevant regulations on waste classification after the end of the product(s) life.



No.2 Guangdong Road, Zhangjiagang Free Trade Zone, Jiangsu, China

Web: [www.dowaytech.com/en](http://www.dowaytech.com/en) E-mail: [info@dowaytech.com](mailto:info@dowaytech.com)

