

Mechanical Dimensions: Inches [mm]

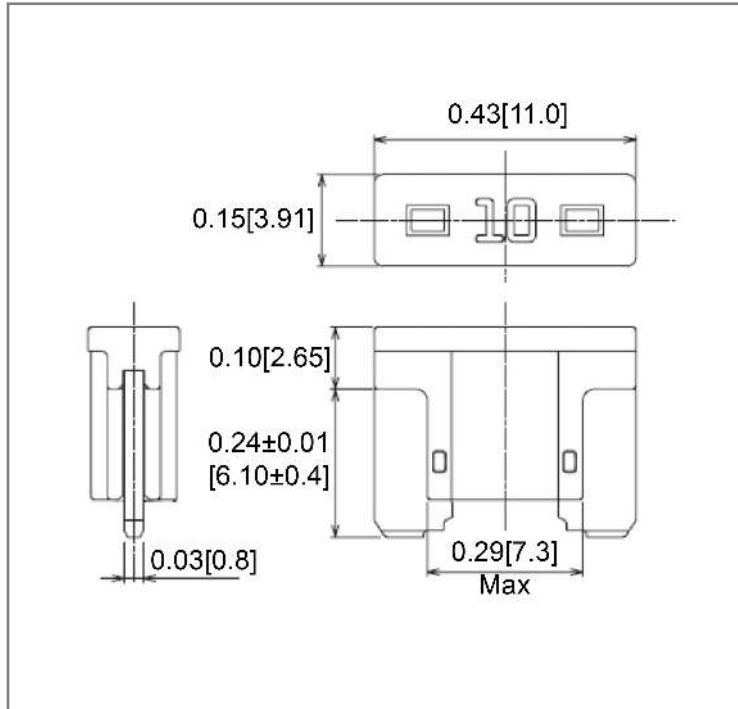

Retail Pack: Inches [mm]

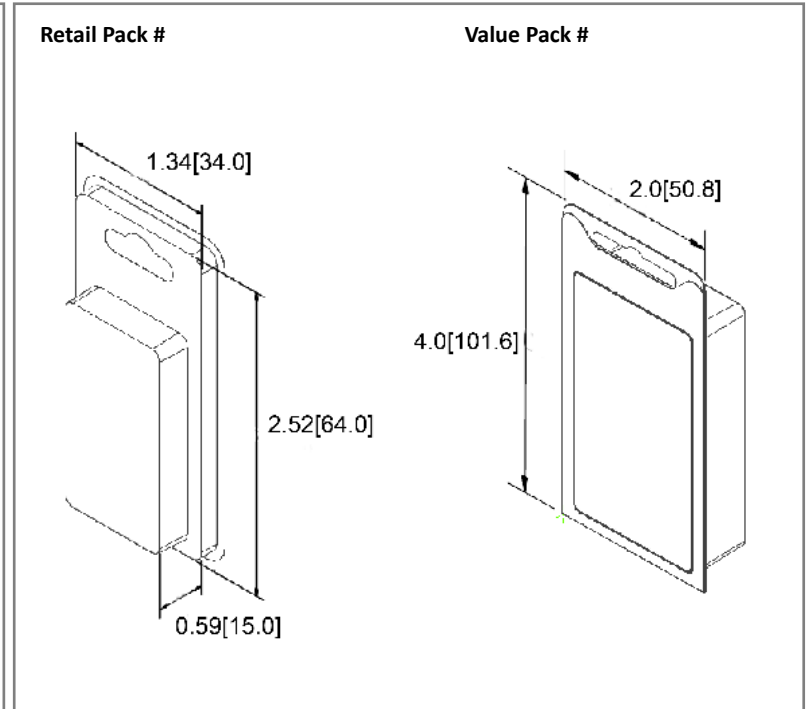

Part Numbers Information

Amperage	Body Color	Bulk Part #	Retail Pack # Blister Card	Pack Size	Value Pack # Clamshell	Pack Size
3A	Violet	ANS-3A	-	-	-	-
4A	Pink	ANS-4A	-	-	-	-
5A	Tan	ANS-5A	ANS-5A-BP	5	ANS-5A-VP	25
7.5A	Brown	ANS-7.5A	ANS-7.5A-BP	5	ANS-7.5A-VP	25
10A	Red	ANS-10A	ANS-10A-BP	5	ANS-10A-VP	25
15A	Blue	ANS-15A	ANS-15A-BP	5	ANS-15A-VP	25
20A	Yellow	ANS-20A	ANS-20A-BP	5	ANS-20A-VP	25
25A	Clear	ANS-25A	ANS-25A-BP	5	ANS-25A-VP	25
30A	Green	ANS-30A	ANS-30A-BP	5	ANS-30A-VP	25

Electrical Specifications

Voltage Rating	32V DC
Interrupting Rating	1000A @ 32 VDC
Testing	SAE, ISO 8820

Material Specifications

Body	PA 66
Terminals	Zinc Alloy

Time vs. Percent of Rated Current

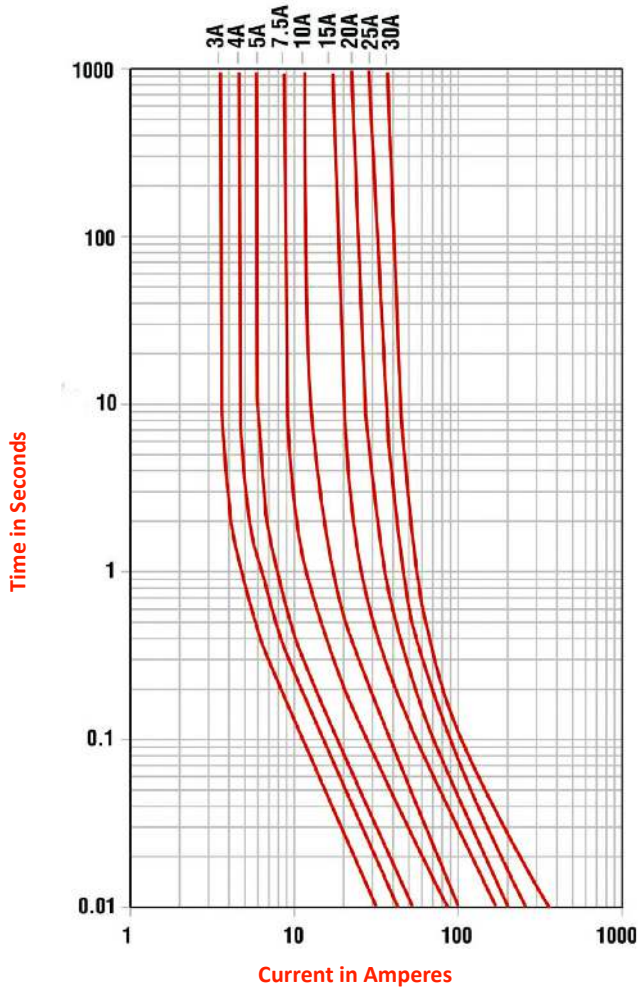

% of Rated Current	Current Rating	Min Hold Time	Max Hold Time
110%	2-30 Amp	100h	-
135%	2-30 Amp	-	1800s
200%	2-30 Amp	-	5s

Rev Date of issue Revision Notes

Designed Approved

C	05-22-2023	Initial Drawing	RC	OF
---	------------	-----------------	----	----