

TLE5501

TMR-Based Angle Sensor



RoHS



ISO26262
compliant

Features

- Tunneling Magneto Resistance (TMR)-based principle
- 360° angle measurement
- Large output signals of up to 0.37 V/V for direct micro controller connection
- Discrete bridge with differential sine and cosine output
- Ratiometric output signals
- Two different pin-outs:
 - E0001: pin compatible to TLE5009, AEC-Q100 compliant (QM)
 - E0002: de-coupled bridges for redundant external angle calculation and highest diagnostic coverage, ISO26262 ASIL-D compliant (requires use of external safety mechanisms)
- Automotive qualified AEC-Q100, Grade 0: $T_A = -40^{\circ}\text{C}$ to 150°C (ambient temperature)
- ESD > 4 kV (HBM)
- RoHS compliant and halogen free package



Functional Safety

- Safety Manual and Safety Analysis Summary Report available on request

Potential applications

The TLE5501 TMR-based angle sensor is designed for angular position sensing in automotive applications with focus on steering angle sensor and BLDC motor commutation.

Product validation

Qualified for automotive applications. Product validation according to AEC-Q100.

Description

Table 1 Derivative Ordering codes

Product type	Marking	Ordering code	Package	Functional Safety Classification	Comment
TLE5501 E0001	5010001	SP001621824	PG-DSO-8	n.a.	pin compatible to TLE5009
TLE5501 E0002	5010002	SP001621828	PG-DSO-8	ISO26262 Compliant	de-coupled bridges

Table of contents

1	Product overview	3
2	Block diagram	4
3	Pin configuration / description	5
4	Application circuit	6
5	General product characteristics	8
5.1	Absolute maximum ratings	8
5.2	Functional range	9
5.3	Thermal resistance	9
6	Functional behavior	10
6.1	Functional description	10
6.2	Safety functions	10
6.3	Failure reactions	10
6.4	Electrical parameters	10
7	Typical performance	14
7.1	Angle error	14
7.2	Hysteresis	15
8	Package	16
8.1	Package info	16
8.2	Package marking	17
8.3	Packing	17
8.4	Die Position inside package	17
9	Revision history	18

1 Product overview

The TLE5501 is a 360° TMR-based angle sensor that detects the orientation of a magnetic field. This is achieved by measuring sine and cosine angle components with Tunneling Magneto Resistance (TMR) elements. These raw signals (sine and cosine) are provided as a differential output signal and can directly be further processed within a micro controller. The large output voltage of the bridge renders any further signal amplification unnecessary.

The TLE5501 is available in two different derivatives:

- TLE5501 E0001 has one VDD pin and is pin-compatible with the GMR-based TLE5009. This option offers a easy change to the TLE5501. The only difference to TLE5009 is the pin 5, which is not used in TLE5501 and provides a temperature and diagnosis function in TLE5009.
- TLE5501 E0002 is a version which has two independent VDD and GND pins, for the P- and N-bridge respectively. In this way, two completely independent bridge signals are generated which can be used in an advanced safety concept to perform a cross-check of the P- and N- signals and achieve a high diagnostic coverage for any sensor malfunction.

Block diagram

2 Block diagram

The TLE5501 consists of 8 TMR resistors, which are arranged in 2 Wheatstone bridges. The resistance of these resistors depends on the direction of the external magnetic field. Each bridge provides a differential output signal, i.e. X (cosine) and Y (sine) signals which can further be processed for angle calculation.

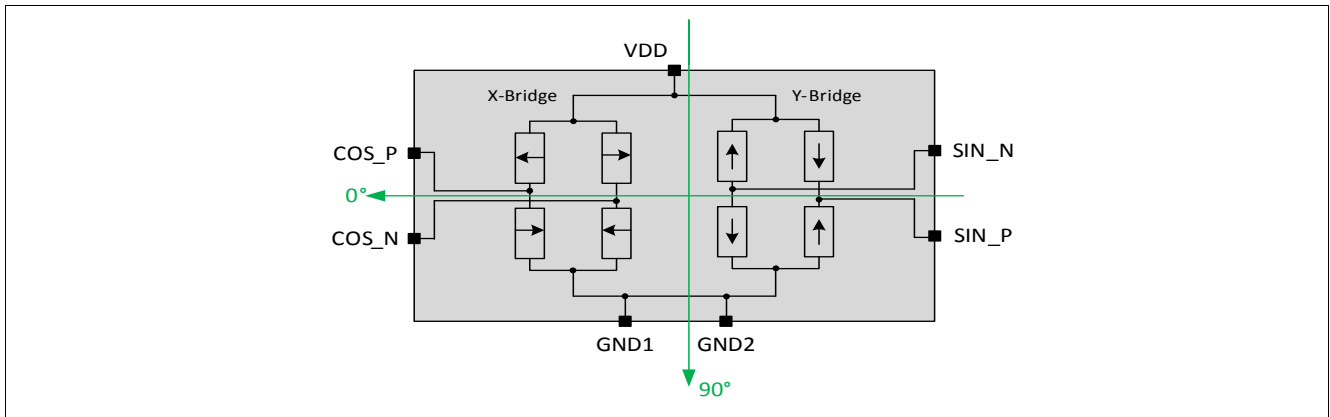

Figure 1 Principle block diagram of discrete TMR bridge, version TLE5501 E0001

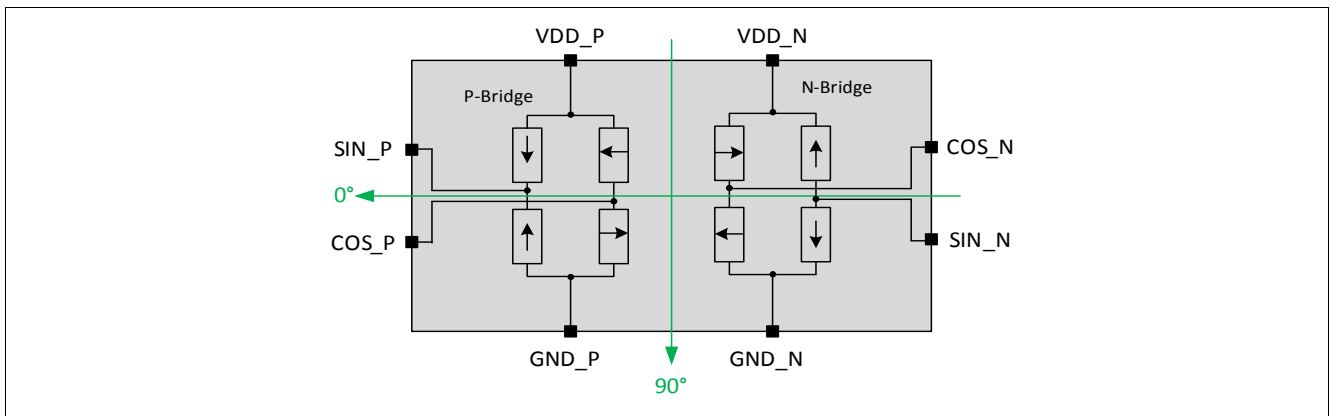

Figure 2 Principle block diagram of discrete TMR bridge, de-coupled version TLE5501 E0002

3 Pin configuration / description

The pin-out of the device is shown in [Table 2](#).

A magnet which rotates counter-clockwise (CCW) leads to an increasing angle value.

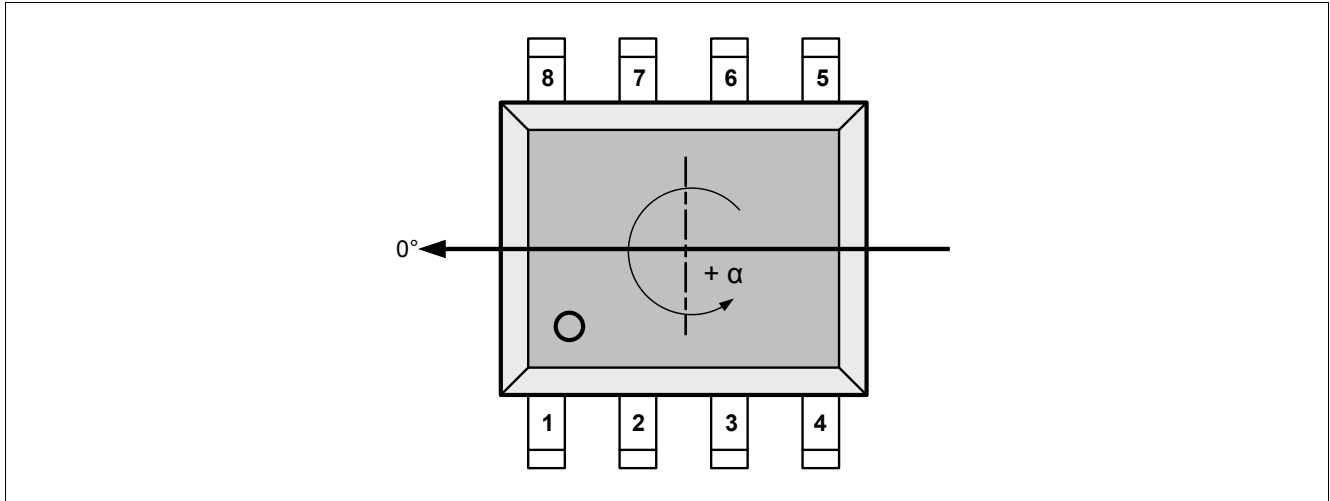

Figure 3 Pin-out of the discrete TMR bridge

Table 2 Pin description (compatible version TLE5501 E0001)

Pin No.	Symbol	In/Out	Function
1	COS_P	O	Analog positive cosine output
2	COS_N	O	Analog negative cosine output
3	GND2	I	Ground, internally connected to GND1
4	GND1	I	Ground
5	n.c		not used, internally connected to GND2
6	VDD	I	Supply voltage
7	SIN_N	O	Analog negative sine output
8	SIN_P	O	Analog positive sine output

Table 3 Pin description (de-coupled version TLE5501 E0002)

Pin No.	Symbol	In/Out	Function
1	SIN_P	O	Analog positive sine output
2	VDD_P	I	Supply voltage P-bridge
3	COS_P	O	Analog positive cosine output
4	GND_P	I	Ground P-bridge
5	COS_N	O	Analog negative cosine output
6	VDD_N	I	Supply voltage N-bridge
7	SIN_N	O	Analog negative sine output
8	GND_N	I	Ground N-bridge

Application circuit

4 Application circuit

Figure 4 to Figure 7 show the application circuit which is proposed for TLE5501. The value for the buffer capacitor C_b has to be adjusted according to the speed of the magnetic input signal. It represents a low-pass filter together with the TMR resistor and limits the bandwidth of the sensor, improves, however, noise performance. Even without any buffer capacitor C_b , the bandwidth of the device is determined by the TMR resistor and the input capacitor of the used ADC. It has to be considered and the ADC sample and hold time has to be adjusted accordingly.

In case the TLE5501 is used in a single-ended configuration, it is recommended to keep the unused pins open.

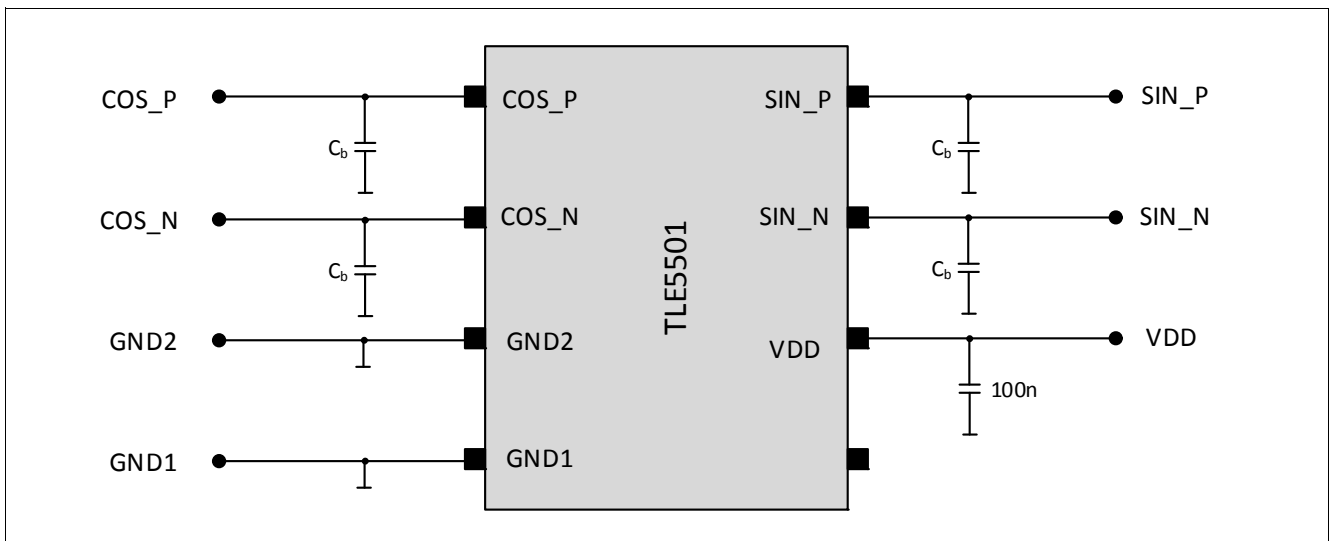

Figure 4 Application circuit for TLE5501 E0001, both bridges used

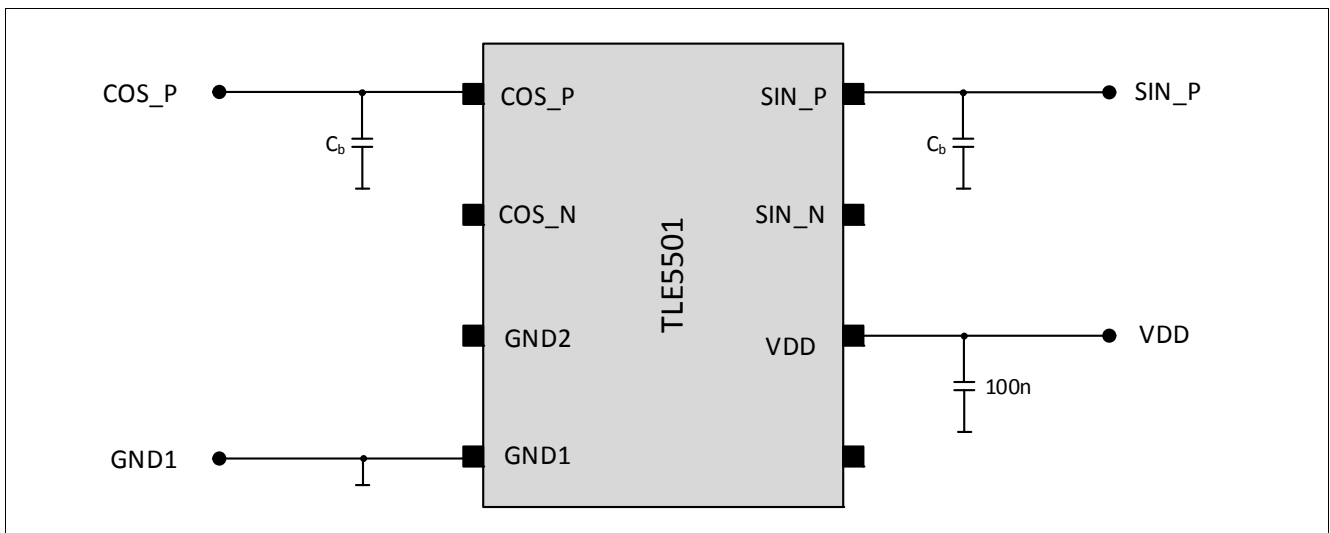

Figure 5 Application circuit for TLE5501 E0001, only one bridge used

Application circuit

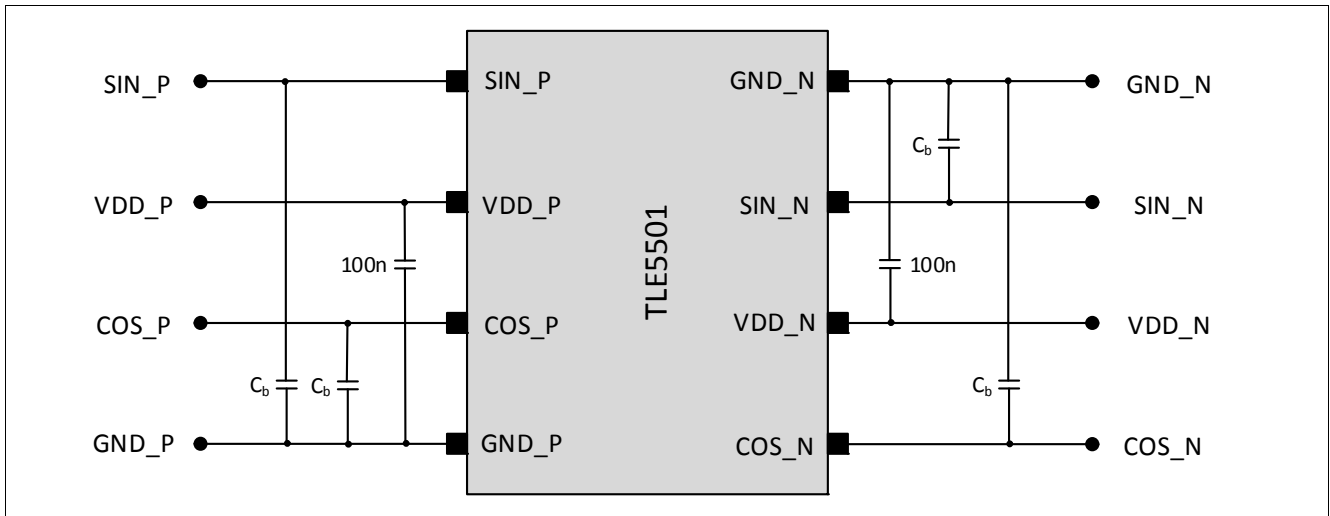

Figure 6 Application circuit for TLE5501 E0002, both bridges used

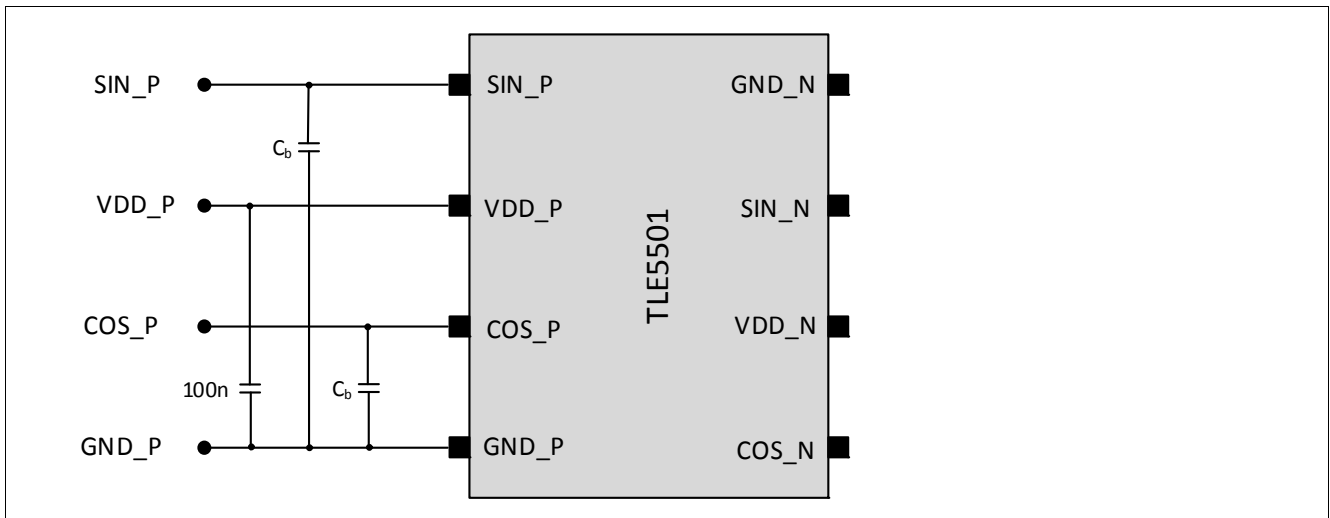

Figure 7 Application circuit for TLE5501 E0002, only one bridge used

General product characteristics

5 General product characteristics

5.1 Absolute maximum ratings

Stresses above the maximum values listed here may cause permanent damage to the device. Exposure to absolute maximum rating conditions for extended periods may affect device reliability. Maximum ratings are absolute ratings; exceeding only one of these values may cause irreversible damage to the device.

Table 4 Maximum ratings for voltages and output current

Parameter	Symbol	Values			Unit	Note or Test Condition
		Min.	Typ.	Max.		
Absolute maximum supply voltage	V_{DD}	-6.5	-	6.5	V	limited to 40 h over lifetime
Maximum ambient temperature	T_A	-40	-	150	°C	Grade 0 qualification
Maximum allowed magnetic field	B_{max}	-	-	200	mT	max 5 min @ $T_A = 25^\circ\text{C}$
Maximum allowed magnetic field	B_{max}	-	-	150	mT	max 5 h @ $T_A = 25^\circ\text{C}$
Storage & Shipment ¹⁾	$T_{storage}$	5	-	40	°C	for dry packed devices, Relative humidity < 90 %, storage time < 3 a

1) See Infineon Application Note: "Storage of Products Supplied by Infineon Technologies"

Table 5 Temperature / lifetime budget

Parameter	Symbol	Values			Unit	Note or Test Condition
		Min.	Typ.	Max.		
Temperature / lifetime budget ¹⁾	$T_{A,max}$	-	-	125	°C	for 1000 h, Grade 1 qualification
		-	-	150	°C	for 1000 h, Grade 0 qualification

1)The angle accuracy depends on the maximum ambient temperature (see [Table 12](#) and [Table 13](#))

Table 6 Lifetime & Ignition Cycles

Parameter	Symbol	Values			Unit	Note or Test Condition
		Min.	Typ.	Max.		
Operating life time	t_{op_life}	15.000	-	-	h	see Table 5
Total life time	t_{tot_life}	19	-	-	a	additional 5 a storage time ¹⁾
Ignition cycles	$N_{ignition}$	3.6E6	-	-		during operating life time t_{op_life}

1) This storage time refers to storage in the module (including magnet) after soldering of the part

General product characteristics

Table 7 ESD voltage

Parameter	Symbol	Values			Unit	Note or Test Condition
		Min.	Typ.	Max.		
Electro-Static-Discharge voltage (HBM), according to ANSI/ESDA/JEDEC JS-001-2010)	V_{HBM}	-4	–	4	kV	HBM contact discharge for all pins
Electro-Static-Discharge voltage (CDM), according to JESD22-C101	V_{CDM}	-0.5	–	0.5	kV	for all pins except corner pins
		-0.75	–	0.75	kV	for corner pins only

5.2 Functional range

The following operating conditions must not be exceeded in order to ensure correct operation of the angle sensor. All parameters specified in the following sections refer to these operating conditions. [Table 8](#) & [Table 9](#) is valid for $-40^{\circ}\text{C} < T_{\text{A}} < 150^{\circ}\text{C}$.

Table 8 Operating range

Parameter	Symbol	Values			Unit	Note or Test Condition
		Min.	Typ.	Max.		
Operating supply voltage	V_{DD}	2.7	–	5.5	V	–
Operating ambient temperature	T_{A}	-40	–	150	$^{\circ}\text{C}$	–
Angle speed	n	–	–	1E6	$^{\circ}/\text{s}$	–

Table 9 Magnetic field range

Parameter	Symbol	Values			Unit	Note or Test Condition
		Min.	Typ.	Max.		
Magnetic field range	B	20	–	100	mT	
Extended magnetic field range	B_{extended}	20	–	130	mT	additional reversible angle error and additional angle error life time drift

5.3 Thermal resistance

The [Table 10](#) describes the thermal resistance of the package.

Table 10 Thermal resistance of DSO-8

Parameter	Symbol	Values			Unit	Note or Test Condition
		Min.	Typ.	Max.		
Thermal resistance DSO-8	R_{thJA}	–	300	350	K/W	Junction to air ¹⁾

1) According to Jedec JESD51-7

6 Functional behavior

6.1 Functional description

The measurement principle of the sensor is based on the TMR (tunneling magneto-resistance) effect.

The sensor measures the angular orientation of the magnetic field vector parallel to the package surface.

The sensor provides a differential sine and a differential cosine analog output signal for external angle calculation.

The provided output signal is ratiometric to the supply voltage.

The sensor has a measurement range of 360°.

6.2 Safety functions

The TLE5501 has no internal safety mechanisms implemented. All diagnostics to verify correct sensor functionality must be implemented externally in the micro controller.

6.3 Failure reactions

As the TLE5501 has no implemented safety mechanisms, potential chip errors will not be indicated by the sensor. They can be detected, however, by proper external mechanisms.

The sensor can withstand a short of any pin to ground without any damage of the sensor.

The sensor can withstand a short of any pin to sensor supply voltage without any damage of the sensor.

The sensor can also withstand a short of a pin to a neighbor pin without any damage.

6.4 Electrical parameters

The indicated parameters apply to the full operating range, unless otherwise specified. The typical values correspond to a supply voltage $V_{DD} = 5.0\text{ V}$ and $T_A = 25^\circ\text{C}$, unless individually specified.

Table 11 Electrical parameters

Parameter	Symbol	Values			Unit	Note or Test Condition
		Min.	Typ.	Max.		
Bridge resistance	R_{bridge}	4000	6000	8000	Ohm	for $T_A = 25^\circ\text{C}$
Temperature coefficient of bridge resistance	TC_{bridge}	-0.124	-0.1	0	%/K	reference temperature: 25°C
Differential output voltage amplitude	$A_{\text{out,diff}}$	270	320	370	mV/V	peak-value, for $T_A = 25^\circ\text{C}$
Single ended output voltage amplitude	$A_{\text{out,se}}$	135	160	185	mV/V	peak-value, for $T_A = 25^\circ\text{C}$
Orthogonality error (single and differential ended)	ϕ	-10	0	10	°	
Amplitude synchronism (single and differential ended)	k	90	100	110	%	for $T_A = 25^\circ\text{C}$
Differential offset voltage	$V_{\text{off,diff}}$	-5	0	5	mV/V	for $T_A = 25^\circ\text{C}$

Functional behavior

Table 11 Electrical parameters (cont'd)

Parameter	Symbol	Values			Unit	Note or Test Condition
		Min.	Typ.	Max.		
Single ended offset voltage	$V_{\text{off,se}}$	-5	0	5	mV/V	referring to $V_{\text{DD}}/2$, for $T_A = 25^\circ\text{C}$
Temperature coefficient of output amplitude (single and differential ended)	TC_{Amp}	-0.145	-0.12	0	%/K	reference temperature: $T_A = 25^\circ\text{C}$
Temperature coefficient of offset voltage (single and differential ended)	TC_{Voff}	-5	0	5	$\mu\text{V/V/K}$	
Supply current	I_S	-	1.67	2.5	mA	@ $V_{\text{DD}} = 5\text{ V} / T_A = 25^\circ\text{C}$ (supply current is calculated from supply voltage and bridge resistance)
Power on delay time	t_{delay}	-	-	1	ms	for a load capacity of $C_L < 30\text{ nF}$
		-	-	4	μs	for a load capacity of $C_L < 100\text{ pF}$

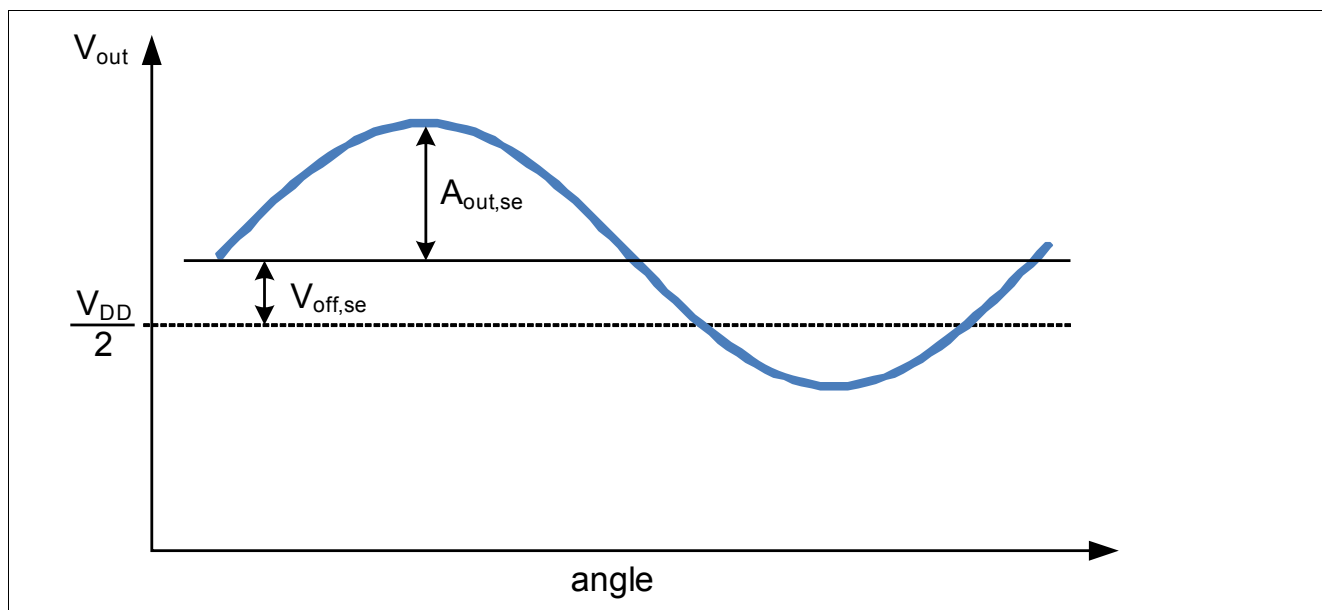

Figure 8 Definition of single ended offset $V_{\text{off,se}}$ and single ended amplitude $A_{\text{out,se}}$

The sensor has a remaining angle error as shown in [Table 12](#) for differential usage and in [Table 13](#) for single ended. The error value refers to $B_z = 0\text{ mT}$. The overall angle error represents the relative angle error. This error describes the deviation from the reference line after zero-angle definition. The reference line is defined in a way that the angle error is symmetric to this line. It is valid for a static magnetic field.

Functional behavior

Table 12 specifies the angle error in the magnetic field range of $25 \text{ mT} < B < 80 \text{ mT}$ with maximum ambient temperature $T_A = 125^\circ\text{C}$ and $T_A = 150^\circ\text{C}$, respectively. Differential output signal is used. For magnetic field values B in the range of $20 \text{ mT} < B < 25 \text{ mT}$ or $80 \text{ mT} < B < 100 \text{ mT}$, a corresponding adder has to be applied to the specified angle accuracy as given in the footnote.

Table 12 Angle error for $T_A < 125^\circ\text{C}$ and $T_A < 150^\circ\text{C}$ (differential)

Parameter	Symbol	Values			Unit	Note or Test Condition
		Min.	Typ.	Max.		
Difference between output angle and real angle ¹⁾ differential signals used	$A_{\text{Err,RT}}$	–	–	0.8	°	at 0 h/25°C, $B = 25 \text{ mT}$ to 80 mT ²⁾ (with compensation of offset, orthogonality and amplitude at 0h/25°C)
Difference between output angle and real angle ¹⁾ differential signals used	$A_{\text{Err,0}}$	–	–	1.0	°	at 0 h/over temperature $T_A = -40^\circ\text{C}$ to 150°C , $B = 25 \text{ mT}$ to 80 mT ²⁾ (with compensation of offset, orthogonality and amplitude at 0h/25°C)
Difference between output angle and real angle ¹⁾ differential signals used	$A_{\text{Err,125}}$	–	–	1.2	°	over lifetime & temperature $T_A = -40^\circ\text{C}$ to 125°C , $B = 25 \text{ mT}$ to 80 mT ²⁾ (with compensation of offset, orthogonality and amplitude at 0h/25°C) lifetime stress according to Grade 1 qualification
Difference between output angle and real angle ¹⁾ differential signals used	$A_{\text{Err,150}}$	–	–	1.5	°	over lifetime & temperature $T_A = -40^\circ\text{C}$ to 150°C , $B = 25 \text{ mT}$ to 80 mT ²⁾ (with compensation of offset, orthogonality and amplitude at 0h/25°C) lifetime stress according to Grade 0 qualification
Angle error due to hysteresis ³⁾	A_{Hyst}	–	–	0.4	°	$20 \text{ mT} < B < 100 \text{ mT}$

- 1) Hysteresis and noise are included in the angle accuracy specification
- 2) For magnetic fields in the range of $20 \text{ mT} < B < 25 \text{ mT}$ or $80 \text{ mT} < B < 100 \text{ mT}$ an adder of 0.2° to the angle error has to be applied
- 3) Hysteresis is the largest measurement angle difference between left rotation and right rotation. The raw signals are corrected with the mean correction parameters of both rotation directions

Functional behavior

Table 13 specifies the angle error in the magnetic field range of $25 \text{ mT} < B < 80 \text{ mT}$ with maximum ambient temperature $T_A = 125^\circ\text{C}$ and $T_A = 150^\circ\text{C}$, respectively. Single ended output signal is used. For magnetic field values B in the range of $20 \text{ mT} < B < 25 \text{ mT}$ or $80 \text{ mT} < B < 100 \text{ mT}$, a corresponding adder has to be applied to the specified angle accuracy as given in the footnote.

Table 13 Angle error for $T_A < 125^\circ\text{C}$ and $T_A < 150^\circ\text{C}$ (single-ended)

Parameter	Symbol	Values			Unit	Note or Test Condition
		Min.	Typ.	Max.		
Difference between output angle and real angle ¹⁾ single-ended signals used	$A_{\text{Err,RT}}$	–	–	0.9	°	at 0 h/25°C, $B = 25 \text{ mT}$ to 80 mT ²⁾ (with compensation of offset, orthogonality and amplitude at 0h/25°C)
Difference between output angle and real angle ¹⁾ single-ended signals used	$A_{\text{Err,0}}$	–	–	1.1	°	at 0 h/over temperature $T_A = -40^\circ\text{C}$ to 150°C , $B = 25 \text{ mT}$ to 80 mT ²⁾ (with compensation of offset, orthogonality and amplitude at 0h/25°C)
Difference between output angle and real angle ¹⁾ single-ended signals used	$A_{\text{Err,125}}$	–	–	1.3	°	over lifetime & temperature $T_A = -40^\circ\text{C}$ to 125°C , $B = 25 \text{ mT}$ to 80 mT ²⁾ (with compensation of offset, orthogonality and amplitude at 0h/25°C) lifetime stress according to Grade 1 qualification
Difference between output angle and real angle ¹⁾ single-ended signals used	$A_{\text{Err,150}}$	–	–	1.6	°	over lifetime & temperature $T_A = -40^\circ\text{C}$ to 150°C , $B = 25 \text{ mT}$ to 80 mT ²⁾ (with compensation of offset, orthogonality and amplitude at 0h/25°C) lifetime stress according to Grade 0 qualification
Angle error due to hysteresis ³⁾	A_{Hyst}	–	–	0.4	°	$20 \text{ mT} < B < 100 \text{ mT}$

- 1) Hysteresis and noise are included in the angle accuracy specification
- 2) For magnetic fields in the range of $20 \text{ mT} < B < 25 \text{ mT}$ or $80 \text{ mT} < B < 100 \text{ mT}$ an adder of 0.2° to the angle error has to be applied
- 3) Hysteresis is the largest measurement angle difference between left rotation and right rotation. The raw signals are corrected with the mean correction parameters of both rotation directions

Typical performance

7 Typical performance

7.1 Angle error

Figure 9 shows the typical angle error of the TLE5501 for different ambient temperatures T_A and magnetic fields B for a one-time compensation of offset, amplitude and non-orthogonality at 25°C and $B = 40$ mT.

Figure 10 shows the typical angle error in case offset, amplitude and non-orthogonality is compensated for each temperature T and magnetic field B .

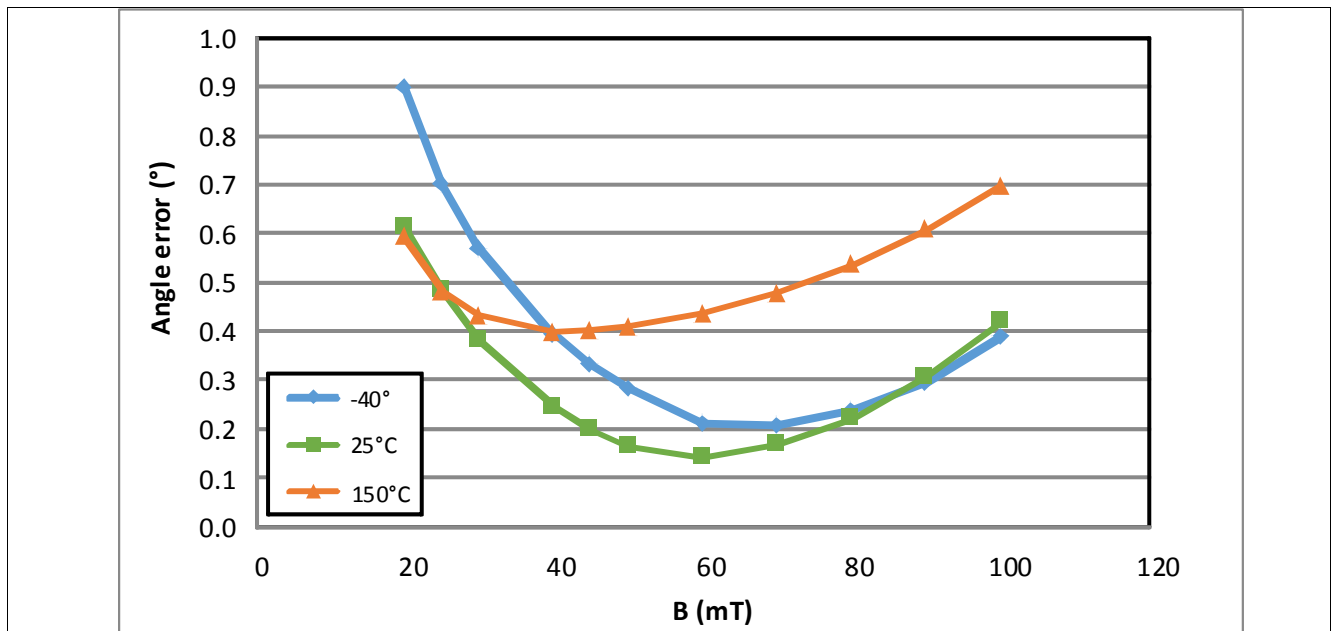

Figure 9 Typical angle error at 0h, differential signals, one-time compensation of offset, amplitude and orthogonality error at 25°C and 40 mT

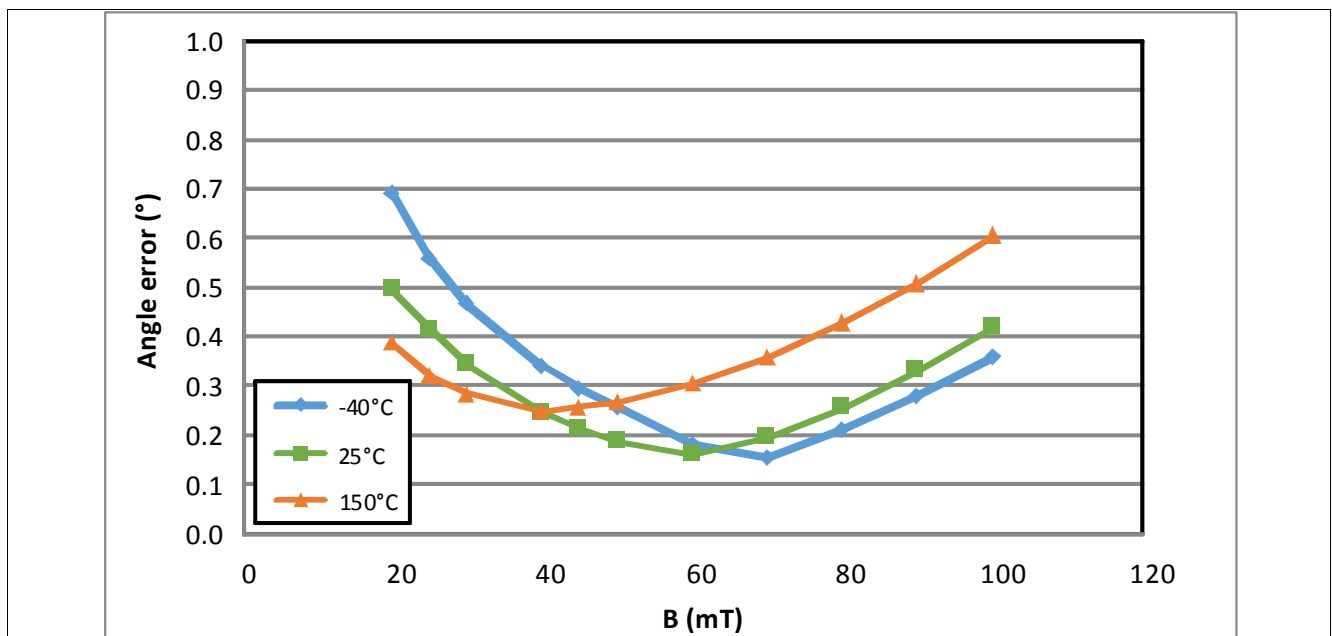

Figure 10 Typical angle error at 0h, differential signals, ideal compensation of offset, amplitude and orthogonality error at each temperature T and magnetic field B

Typical performance

7.2 Hysteresis

Figure 11 shows the typical hysteresis of the TLE5501.

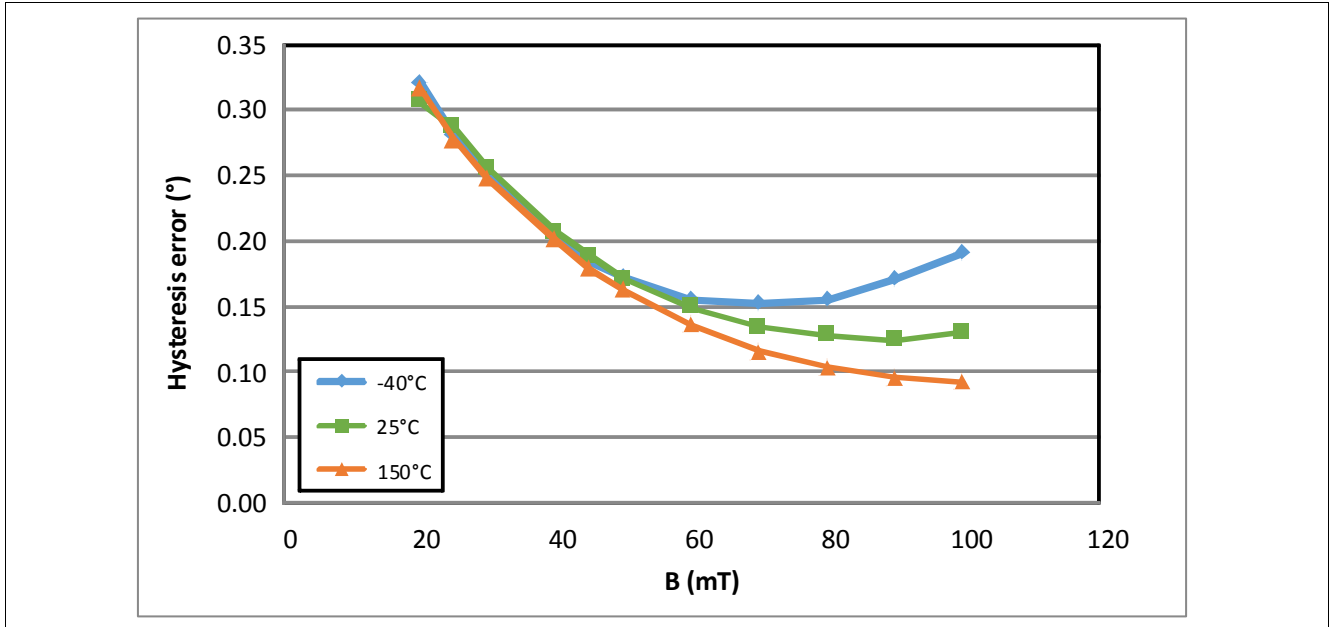

Figure 11 Typical hysteresis

Package

8 Package

8.1 Package info

The package is qualified with a MSL level of 3. It is halogen free, lead free and RoHS compliant.

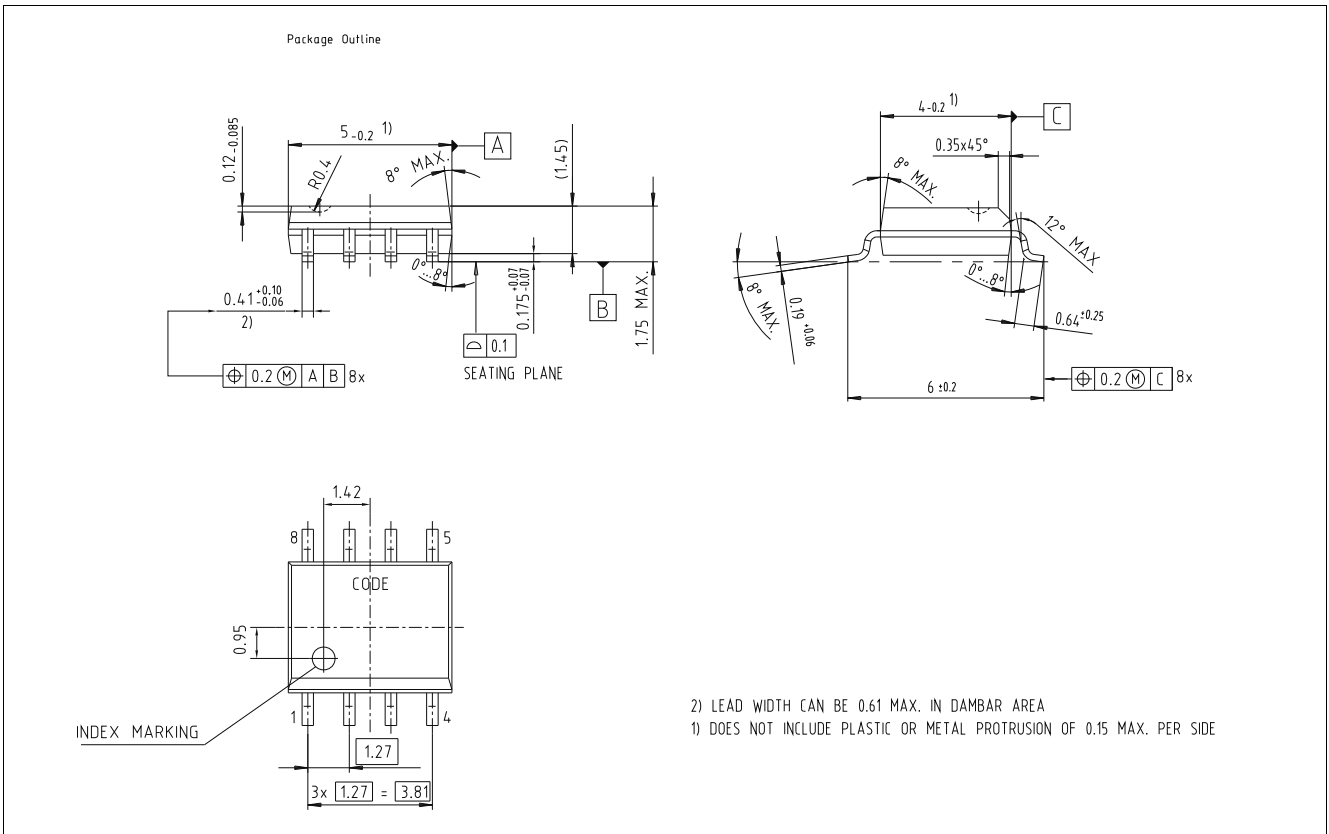

Figure 12 Package outline

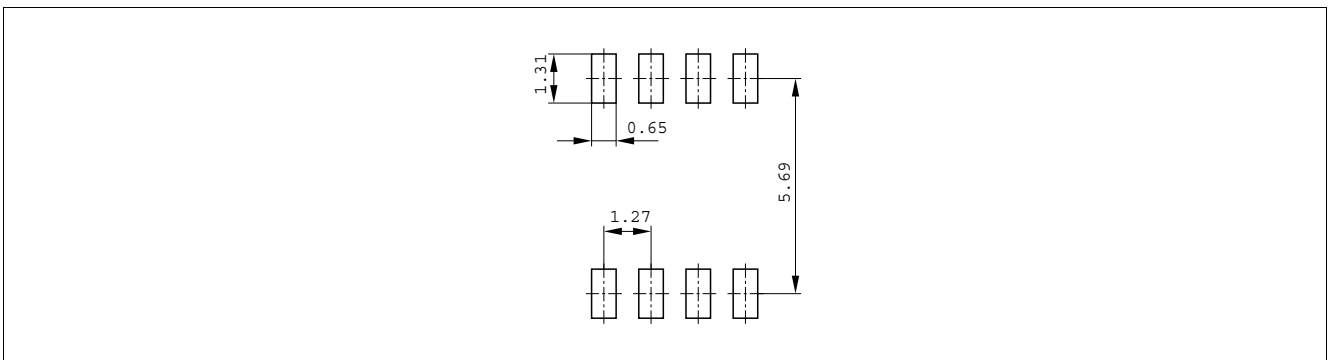

Figure 13 Footprint

Package

8.2 Package marking

The marking on the front side of the package identifies the type of the sensor, the manufacturing lot information and the manufacturing date code.

Table 14 Marking

Position	Marking	Description
1st Line	5010001 / 5010002	See ordering code in Table 1
2nd Line	xxx	Lot code
3rd Line	Gxxxx	G: green, 4-digit: date code

8.3 Packing

The packing of the device is in tape & reel.

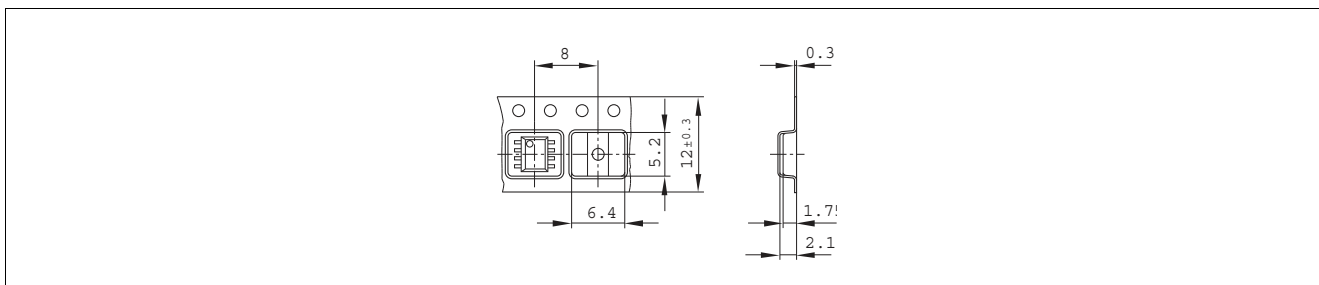

Figure 14 Packing

8.4 Die Position inside package

The position of the sensitive element inside the package is specified in [Figure 15](#).

The size of the sensitive TMR area is 315 μm x 315 μm with the center being in the center of the package.

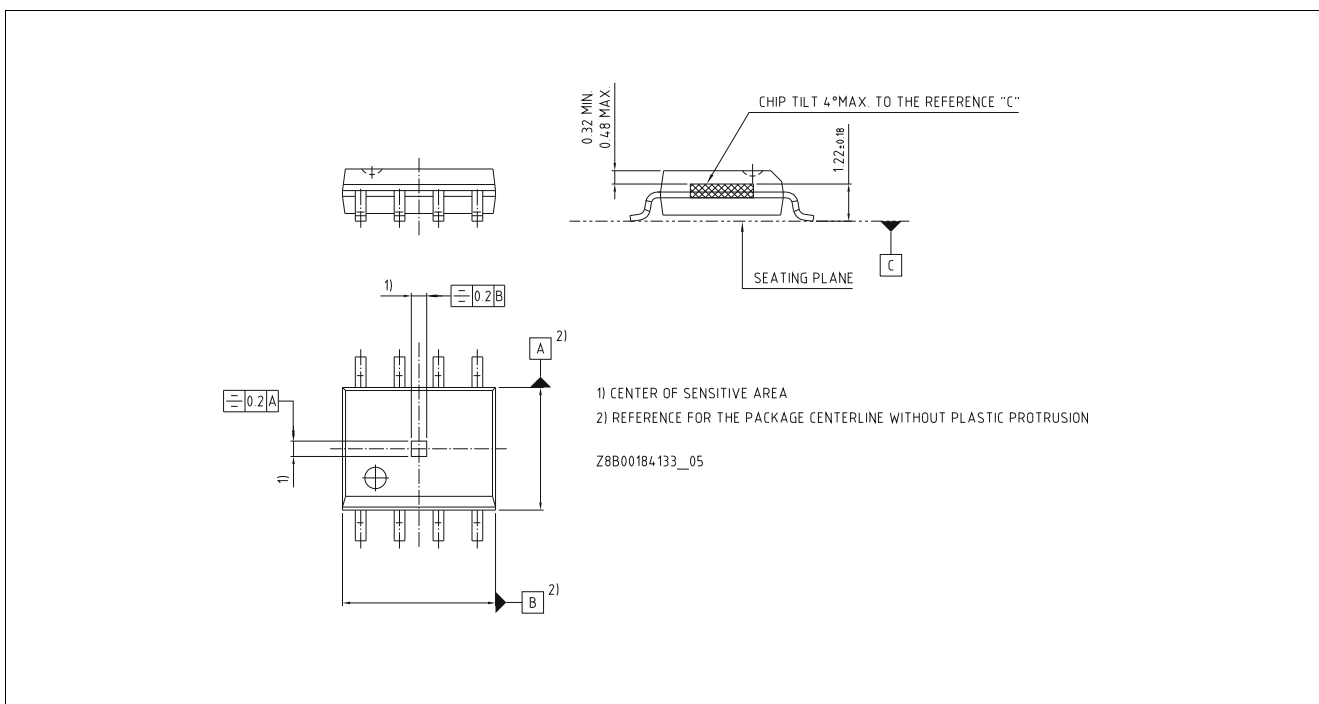

Figure 15 Die in package

Revision history

9 Revision history

Revision	Date	Changes
1.0	2018-07-24	Initial creation

Trademarks

All referenced product or service names and trademarks are the property of their respective owners.

Edition 2018-07-24

Published by

Infineon Technologies AG

81726 Munich, Germany

© 2018 Infineon Technologies AG.

All Rights Reserved.

Do you have a question about any aspect of this document?

Email: erratum@infineon.com

Document reference

IMPORTANT NOTICE

The information given in this document shall in no event be regarded as a guarantee of conditions or characteristics ("Beschaffheitsgarantie").

With respect to any examples, hints or any typical values stated herein and/or any information regarding the application of the product, Infineon Technologies hereby disclaims any and all warranties and liabilities of any kind, including without limitation warranties of non-infringement of intellectual property rights of any third party.

In addition, any information given in this document is subject to customer's compliance with its obligations stated in this document and any applicable legal requirements, norms and standards concerning customer's products and any use of the product of Infineon Technologies in customer's applications.

The data contained in this document is exclusively intended for technically trained staff. It is the responsibility of customer's technical departments to evaluate the suitability of the product for the intended application and the completeness of the product information given in this document with respect to such application.

For further information on technology, delivery terms and conditions and prices, please contact the nearest Infineon Technologies Office (www.infineon.com).

WARNINGS

Due to technical requirements products may contain dangerous substances. For information on the types in question please contact your nearest Infineon Technologies office.

Except as otherwise explicitly approved by Infineon Technologies in a written document signed by authorized representatives of Infineon Technologies, Infineon Technologies' products may not be used in any applications where a failure of the product or any consequences of the use thereof can reasonably be expected to result in personal injury.