

Description

The ICS667-01 is a low-cost, low jitter, high-performance PLL clock synthesizer designed to produce the 74.176 MHz clock necessary for HDTV systems. Using IDT's patented analog Phase-Locked Loop (PLL) techniques, the device accepts a 27 MHz crystal or clock input. The zero ppm synthesis error exactly locks the display to the digital stream.

IDT manufactures the largest variety multimedia clock synthesizers for all applications. Consult IDT to eliminate crystals and oscillators from your board.

Features

- Packaged in 8-pin SOIC
- Pb (lead) free package, RoHS compliant
- Input frequency of 27 MHz
- Zero ppm synthesis error in output clock
- 3.3 V \pm 5% operating supply
- Ideal for HDTV applications and oscillator manufacturers
- Advanced, low power, sub-micron CMOS process

Block Diagram

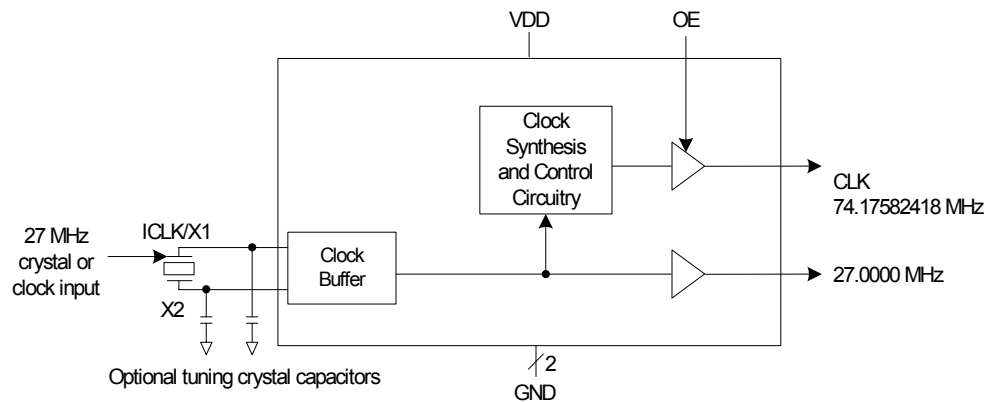

Pin Assignment

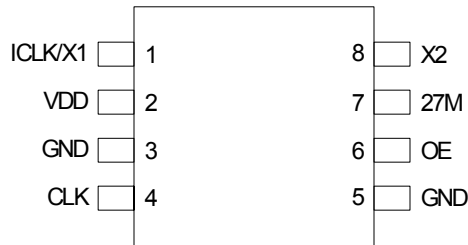

Pin Descriptions

Pin Number	Pin Name	Pin Type	Pin Description
1	ICLK/X1	XI	Crystal connection. Connect to a 27 MHz fundamental crystal or clock.
2	VDD	Power	Connect to +3.3 V.
3	GND	Power	Connect to ground.
4	CLK	Output	74.17582418 MHz.
5	GND	Power	Connect to ground.
6	OE	Input	Output enable. Tri-states CLK output when low. Internal pull-up to VDD.
7	27M	Output	27 MHz buffered clock or crystal oscillator output.
8	X2	XO	Crystal connection. Connect to a 27 MHz crystal, or leave unconnected for clock input.

External Components

Decoupling Capacitor

As with any high performance mixed-signal IC, the ICS667-01 must be isolated from system power supply noise to perform optimally.

A decoupling capacitor of 0.01 μ F must be connected between VDD and GND on pins 2 and 3. It must be connected close to the ICS667-01 to minimize lead inductance. Pin 5 can be connected to pin 3. No external power supply filtering is required for the ICS667-01.

Series Termination Resistor

A 33 Ω terminating resistor can be used next to the clock outputs for trace lengths over one inch.

Crystal Load Capacitors

The total on-chip capacitance is approximately 18 pF. A parallel resonant, fundamental mode, AT cut 27 MHz crystal should be used. The device crystal connections should

include pads for small capacitors from X1 to ground and from X2 to ground. These capacitors are used to adjust the stray capacitance of the board to match the nominally required crystal load capacitance. Because load capacitance can only be increased in this trimming process, it is important to keep stray capacitance to a minimum by using very short PCB traces (and no vias) between the crystal and device. Crystal capacitors, if needed, must be connected from each of the pins X1 and X2 to ground.

The value (in pF) of these crystal caps should equal $(C_L - 16 \text{ pF})^2$. In this equation, C_L = crystal load capacitance in pF. Example: For a crystal with an 18 pF load capacitance, each crystal capacitor would be 4 pF $[(18 - 16) \times 2] = 4$.

Absolute Maximum Ratings

Stresses above the ratings listed below can cause permanent damage to the ICS667-01. These ratings, which are standard values for IDT commercially rated parts, are stress ratings only. Functional operation of the device at these or any other conditions above those indicated in the operational sections of the specifications is not implied. Exposure to absolute maximum rating conditions for extended periods can affect product reliability. Electrical parameters are guaranteed only over the recommended operating temperature range.

Item	Rating
Supply Voltage, VDD	7 V
All Inputs and Outputs	-0.5 V to VDD+0.5 V
Ambient Operating Temperature	0 to +70° C
Storage Temperature	-65 to +150° C
Soldering Temperature	260° C

Recommended Operation Conditions

Parameter	Min.	Typ.	Max.	Units
Ambient Operating Temperature	0		+70	° C
Power Supply Voltage (measured in respect to GND)	+3.150	3.3	+3.465	V

DC Electrical Characteristics

VDD=3.3 V \pm 5% unless otherwise noted, Ambient temperature 0 to +70° C

Parameter	Symbol	Conditions	Min.	Typ.	Max.	Units
Operating Voltage	VDD		3.15	3.3	3.465	V
Input High Voltage	V _{IH}	ICLK, OE	2.0			V
Input Low Voltage	V _{IL}	ICLK, OE			0.8	V
Output High Voltage	V _{OH}	I _{OH} = -4 mA	VDD-0.4			V
Output Low Voltage	V _{OL}	I _{OL} = 4 mA			0.4	V
Operating Supply Current	IDD	No load		30		mA
Short Circuit Current		Each output		\pm 50		mA
Input Capacitance	C _{IN}			7		pF

AC Electrical Characteristics

VDD = 3.3V ± 5%, C_L = 15pF unless otherwise noted, Ambient Temperature 0 to +70°C

Parameter	Symbol	Conditions	Min.	Typ.	Max.	Units
Input Frequency	F _{IN}			27		MHz
Frequency Error, Output Clock					0	ppm
Output Clock Rise Time	t _{OR}	0.8 to 2.0 V			1.5	ns
Output Clock Fall Time	t _{OF}	2.0 to 8.0 V			1.5	ns
Output Clock Duty Cycle		at 1.4 V	40	50	60	%
Maximum Absolute Jitter, short term	t _{ja}	Deviation from mean		200		ps
Maximum Absolute Jitter, Long term term over 1μs	t _{jl}	Deviation from mean		500		ps
Output Enable Time		OE going from Low to High		20		ns
Internal Pull-up Resistor	R _{PUP}	OE pin		750		kΩ

Thermal Characteristics

Parameter	Symbol	Conditions	Min.	Typ.	Max.	Units
Thermal Resistance Junction to Ambient	θ _{JA}	Still air		150		°C/W
	θ _{JA}	1 m/s air flow		140		°C/W
	θ _{JA}	3 m/s air flow		120		°C/W
Thermal Resistance Junction to Case	θ _{JC}			40		°C/W

Marking Diagram

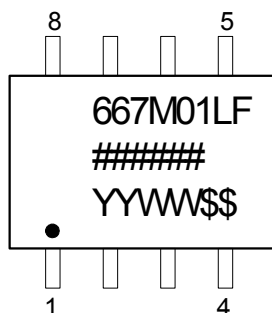

Notes:

- ##### is the lot number.
- YYWW is the last two digits of the year and week that the part was assembled.
- Bottom marking: (origin)
Origin = country of origin if other than USA.
- “LF” denotes Pb (lead) free package.

Package Outline and Package Dimensions (8-pin SOIC, 150 Mil. Narrow Body)

Package dimensions are kept current with JEDEC Publication No. 95

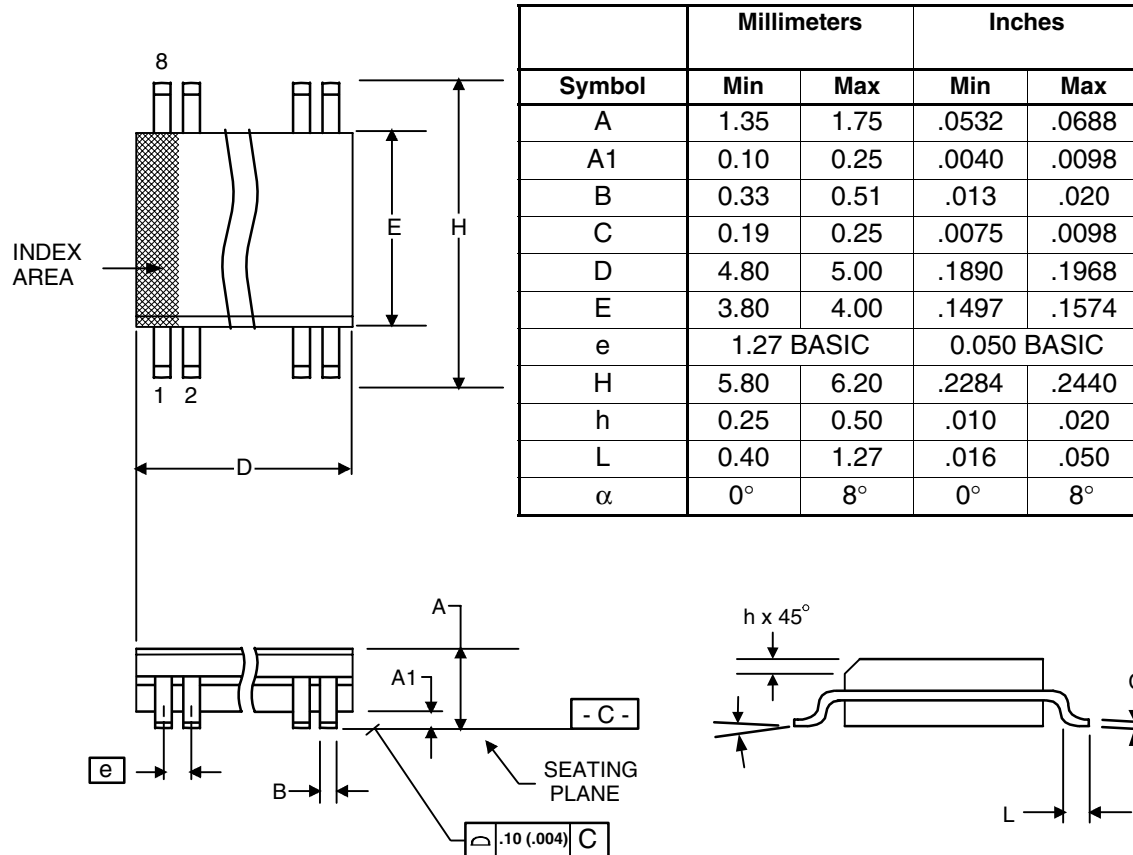

Ordering Information

Part / Order Number	Marking	Shipping Packaging	Package	Temperature
667M-01LF	see page 5	Tubes	8-pin SOIC	0 to +70° C
667M-01LFT		Tape and Reel	8-pin SOIC	0 to +70° C

"LF" suffix to the part number are the Pb-Free configuration and are RoHS compliant.

While the information presented herein has been checked for both accuracy and reliability, Integrated Device Technology (IDT) assumes no responsibility for either its use or for the infringement of any patents or other rights of third parties, which would result from its use. No other circuits, patents, or licenses are implied. This product is intended for use in normal commercial applications. Any other applications such as those requiring extended temperature range, high reliability, or other extraordinary environmental requirements are not recommended without additional processing by IDT. IDT reserves the right to change any circuitry or specifications without notice. IDT does not authorize or warrant any IDT product for use in life support devices or critical medical instruments.

IMPORTANT NOTICE AND DISCLAIMER

RENESAS ELECTRONICS CORPORATION AND ITS SUBSIDIARIES (“RENESAS”) PROVIDES TECHNICAL SPECIFICATIONS AND RELIABILITY DATA (INCLUDING DATASHEETS), DESIGN RESOURCES (INCLUDING REFERENCE DESIGNS), APPLICATION OR OTHER DESIGN ADVICE, WEB TOOLS, SAFETY INFORMATION, AND OTHER RESOURCES “AS IS” AND WITH ALL FAULTS, AND DISCLAIMS ALL WARRANTIES, EXPRESS OR IMPLIED, INCLUDING, WITHOUT LIMITATION, ANY IMPLIED WARRANTIES OF MERCHANTABILITY, FITNESS FOR A PARTICULAR PURPOSE, OR NON-INFRINGEMENT OF THIRD PARTY INTELLECTUAL PROPERTY RIGHTS.

These resources are intended for developers skilled in the art designing with Renesas products. You are solely responsible for (1) selecting the appropriate products for your application, (2) designing, validating, and testing your application, and (3) ensuring your application meets applicable standards, and any other safety, security, or other requirements. These resources are subject to change without notice. Renesas grants you permission to use these resources only for development of an application that uses Renesas products. Other reproduction or use of these resources is strictly prohibited. No license is granted to any other Renesas intellectual property or to any third party intellectual property. Renesas disclaims responsibility for, and you will fully indemnify Renesas and its representatives against, any claims, damages, costs, losses, or liabilities arising out of your use of these resources. Renesas' products are provided only subject to Renesas' Terms and Conditions of Sale or other applicable terms agreed to in writing. No use of any Renesas resources expands or otherwise alters any applicable warranties or warranty disclaimers for these products.

(Disclaimer Rev.1.0 Mar 2020)

Corporate Headquarters

TOYOSU FORESIA, 3-2-24 Toyosu,
Koto-ku, Tokyo 135-0061, Japan
www.renesas.com

Contact Information

For further information on a product, technology, the most up-to-date version of a document, or your nearest sales office, please visit:
www.renesas.com/contact/

Trademarks

Renesas and the Renesas logo are trademarks of Renesas Electronics Corporation. All trademarks and registered trademarks are the property of their respective owners.