

used for: D-SUB

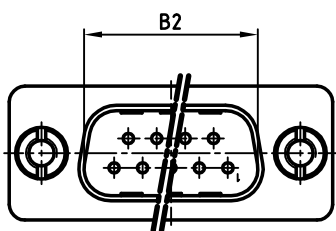
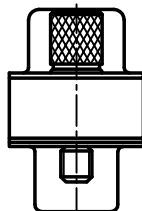
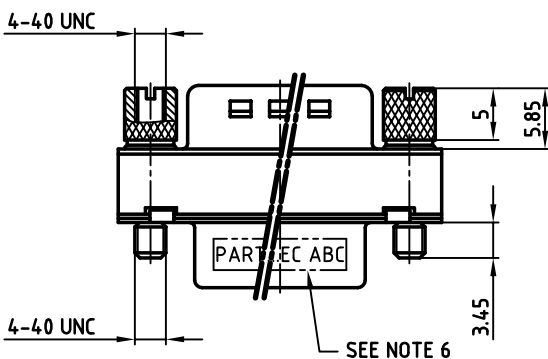
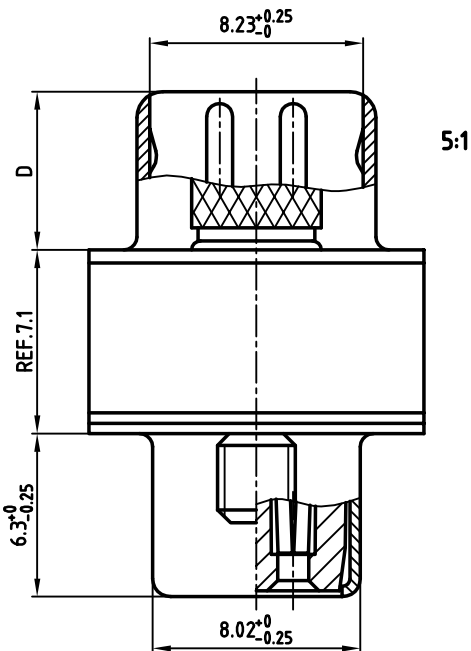
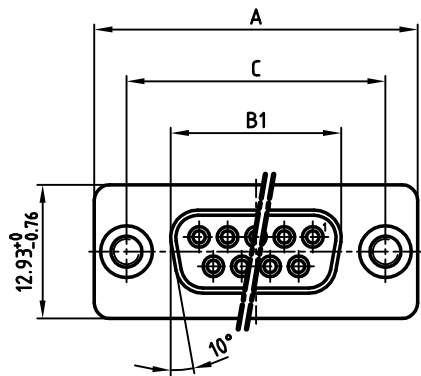

POS.	A -0.76	B1 -0.25	B2 ±0.25	C	D -0.3	PART NO.
15	39.52	24.79	25.12	33.30 ^{+0.15} / _{-0.1}	6.12	163C50019X
25	53.42	38.50	38.84	47.04 ±0.13	5.99	163C50029X
37	69.70	54.96	55.30	63.50 ±0.13	5.99	163C50039X

NOTES:

- METALSHELLS: STEEL; min. 315µin TIN OVER 40-80µin NICKEL
- INSULATORS: PBTP GF UL 94 V-0, BLACK
- CONTACTS: COPPER ALLOY
PLATING: 30µin HARD GOLD over min. 50min NICKEL
- ADAPTER SCREW: COPPER ALLOY; NICKEL PLATED
- MAXIMUM TORQUE VALUE FOR THREAD: 6in.LB
- CONNECTOR IS PART MARKED: PART NO. CONEC ABC



APPROVAL * FREIGABE * DEBLOCAGE * AUTORIZACION * APPROVAL

CUSTOMER APPROVAL DATE:

NAME: TITLE:

COMPANY NAME:

APPROVAL * FREIGABE * DEBLOCAGE * AUTORIZACION * APPROVAL

THIS DRAWING MAY NOT BE COPIED OR REPRODUCED IN ANY WAY, AND MAY NOT BE PASSED ON TO A THIRD PARTY, WITHOUT WRITTEN PERMISSION. OWNERSHIP AND COPYRIGHT OF CONEC GmbH DO NOT ALTER CAD DRAWING BY HAND

rev.	description	date	name

tolerance dim. in mm

scale: 2:1 (5:1)

material: SEE NOTES

title: **D-SUB ADAPTER**
15-37pos.
Plug / Socket

dwg no: AutoCAD 2006

16K2A897

part no: SEE TABLE

CONEC

DIN-A

3

sh: 1/1