

# Vertical Cavity Surface Emitting Laser in ST Optical Sub-Assembly OPV315AT, OPV315BT, OPV315YAT, OPV315YBT

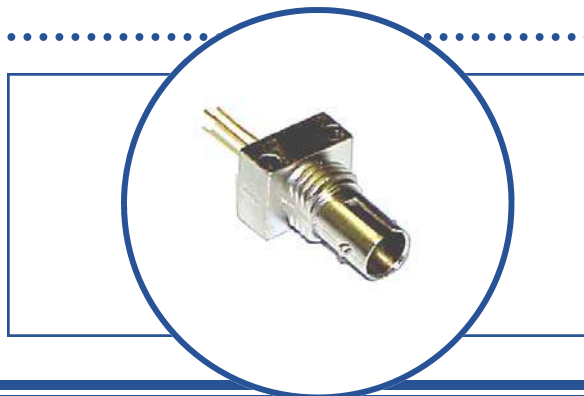

## Features:

- 850 nm VCSEL technology
- High thermal stability
- Up to 2.5 Gbps
- Recommended for multimode fiber applications
- Microbead lens
- Pin out and attenuation options available on request
- Burned in for communication level reliability
- High optical coupling to MM fiber
- ST\* style receptacle



## Description:

The OPV315AT and OPV315BT are high performance 850nm VCSEL packaged for high speed communication links. OPV315AT and OPV315BT combines all the performance advantages of a VCSEL with the addition of a power monitor diode for precise control of optical power.

The OPV315YAT and OPV315YBT are identical electrically and optically and differ only in pin out. Refer to mechanical drawings for details.

This product's combination of features including high speed, high output power and concentric beam makes it an ideal transmitter for integration into all types of data communications equipment.

## Applications:

- Fibre Channel
- Gigabit Ethernet
- ATM
- VSR (Very Short Reach)
- Intra-system links
- Optical backplane interconnects

## Absolute Maximum Ratings ( $T_A = 25^\circ\text{C}$ unless otherwise noted)

Storage Temperature	-40° C to +125° C
Operating Temperature	0° C to +85° C
Soldering Lead Temperature	260° C for 10 Seconds
Maximum Forward Peak Current, Continuous	12 mA
Maximum Reverse Voltage	5 V
Maximum Forward Current, pulsed (1µs P.W., 10% D.C.)	48mA

\* - ST is a registered trademark of AT&T



Additional laser safety information can be found on the Optek website. See application #221. Classification is not marked on the device due to space limitations. See package outline for center-line of optical radiance. Operating devices beyond maximum rating may cause devices to exceed rated classification



RoHS

OPTEK reserves the right to make changes at any time in order to improve design and to supply the best product possible.

**Vertical Cavity Surface Emitting Laser in ST  
Optical Sub-Assembly  
OPV315AT, OPV315BT, OPV315YAT, OPV315YBT**



**Electrical/Optical Characteristics** (at 25 °C unless otherwise specified)

SYMBOL	PARAMETER	MIN	TYP	MAX	UNITS	TEST CONDITION
P <sub>T50</sub>	Total Coupled Power 50/125 μm Fiber	300			μW	I <sub>F</sub> = 7 mA
		200			μW	I <sub>F</sub> = 7 mA
I <sub>TH</sub>	Threshold Current	0.8		3.0	mA	Note 1
V <sub>F</sub>	Forward Voltage	1.6		2.2	V	I <sub>F</sub> = 7 mA
I <sub>R</sub>	Reverse Current			100	nA	V <sub>R</sub> = 5 V
R <sub>S</sub>	Series Resistance	20		55	ohms	Note 2
η	Slope Efficiency	30			μW/mA	Note 3
		20			μW/mA	Note 3
I <sub>RPD</sub>	Reverse Current, photodiode			35	nA	V <sub>R</sub> = 40 V
	Linearity	0.00				Note 4
I <sub>M</sub>	Monitor Current	30			μA	I <sub>F</sub> = 7 mA, V <sub>R</sub> = 5 V
λ	Wavelength	840		860	nm	
Δλ	Optical Bandwidth			0.85	nm	
t <sub>r</sub>	Rise Time		90		ps	20% to 80%
t <sub>f</sub>	Fall Time		120		ps	80% to 20%
N <sub>RI</sub>	Relative Intensity Noise		-123		db/Hz	
Δη/ΔT	Temp Coefficient of Slope Efficiency		-0.5		%/°C	0° - 70° C
ΔI <sub>TH</sub>	Temp Variance of Threshold Current		±1.0		mA	0° - 70° C
Δλ/ΔT	Temp Coefficient of Wavelength		0.06		nm/°C	0° - 70° C
ΔV <sub>f</sub> /ΔT	Temperature Coefficient for V <sub>F</sub>		-2.5		mV/°C	

NOTES:

- (1) Threshold Current is based on the two line intersection method specified in Telcordia GR-468-Core. Line 1 from 4 mA to 6 mA. Line 2 from 0 mA to 0.5 mA.
- (2) Series Resistance is the slope of the Voltage-Current line from 5 to 8 mA.
- (3) Slope efficiency, is the slope of the best fit LI line from 5 mA to 8 mA using no larger than .25 mA test interval points. Measured with a 50/125 μm fiber.
- (4) Linearity—Using data points taken for slope efficiency above, data L/delta I shall be calculated for each adjacent pair of points.

OPTEK reserves the right to make changes at any time in order to improve design and to supply the best product possible.

**Vertical Cavity Surface Emitting Laser in ST  
Optical Sub-Assembly  
OPV315AT, OPV315BT, OPV315YAT, OPV315YBT**



**Normalized Output Power vs. Forward Current**

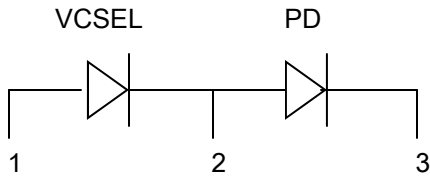
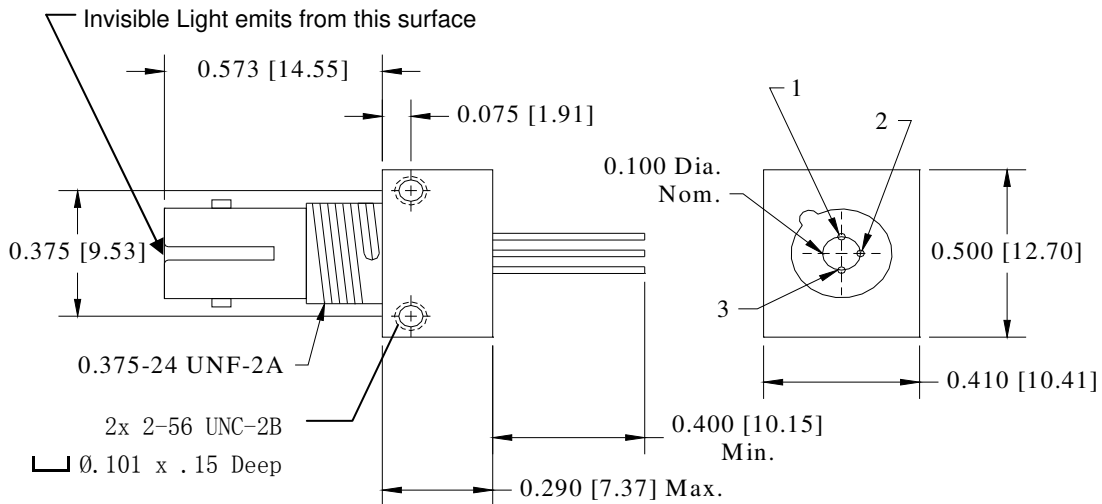
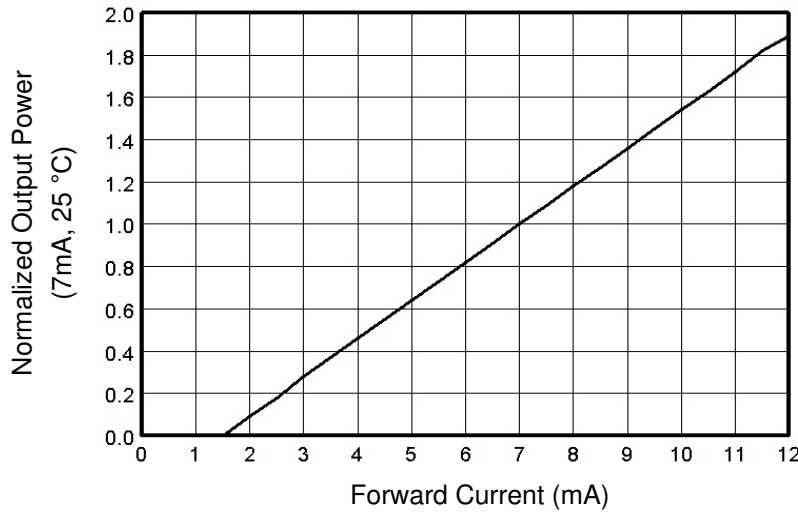

OPV315AT, OPV315BT	
Pin	Connection
1	VCSEL Anode
2	VCSEL Cathode/PD Anode
3	PD Cathode

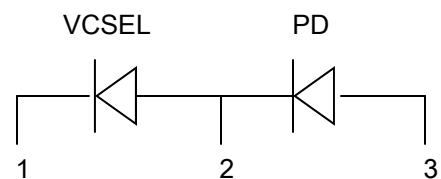

OPV315YAT, OPV315YBT	
Pin	Connection
1	VCSEL Cathode
2	VCSEL Anode/PD Cathode
3	PD Anode

OPTEK reserves the right to make changes at any time in order to improve design and to supply the best product possible.