

ADS7128 Small, 8-Channel, 12-Bit ADC With I²C Interface, GPIOs, and CRC

1 Features

- Small package size:
 - 3-mm × 3-mm WQFN
- 8 channels configurable as any combination of:
 - Up to 8 analog inputs, digital inputs, or digital outputs
- GPIOs for I/O expansion:
 - Open-drain, push-pull digital outputs
- Analog watchdog:
 - Programmable thresholds per channel
 - Event counter for transient rejection
- Wide operating ranges:
 - AVDD: 2.35 V to 5.5 V
 - DVDD: 1.65 V to 5.5 V
 - –40°C to +85°C temperature range
- CRC for read/write operations:
 - CRC on data read/write
 - CRC on power-up configuration
- I²C interface:
 - Up to 3.4 MHz (high-speed mode)
 - 8 configurable I²C addresses
- Programmable averaging filters
- Root-mean-square module:
 - 16-bit true RMS output
 - Programmable RMS time window
- Zero-crossing-detect module:
 - ZCD output corresponding to any analog input
 - Built-in transient rejection and hysteresis
 - Digitally adjustable detection threshold

2 Applications

- [Mobile robot CPU boards](#)
- [Refrigerators and freezers](#)
- [Digital multimeters \(DMM\)](#)
- [Rack servers](#)

3 Description

The ADS7128 is an easy-to-use, 8-channel, multiplexed, 12-bit, successive approximation register analog-to-digital converter (SAR ADC). The eight channels can be independently configured as either analog inputs, digital inputs, or digital outputs. The device has an internal oscillator for ADC conversion processes.

The ADS7128 communicates via an I²C-compatible interface and operates in either autonomous or single-shot conversion mode. The ADS7128 implements analog watchdog function by event-triggered interrupts per channel using a digital window comparator with programmable high and low thresholds, hysteresis, and an event counter. The ADS7128 has a built-in cyclic redundancy check (CRC) for data read/write operations and the power-up configuration. The ADS7128 features a root-mean-square (RMS) module that computes a 16-bit true RMS result for any analog input channel. The integrated zero-crossing-detect (ZCD) module allows for transient rejection and hysteresis near the configurable threshold crossings.

Device Information⁽¹⁾

PART NAME	PACKAGE	BODY SIZE (NOM)
ADS7128	WQFN (16)	3.00 mm × 3.00 mm

(1) For all available packages, see the orderable addendum at the end of the datasheet.

ADS7128 Block Diagram and Applications

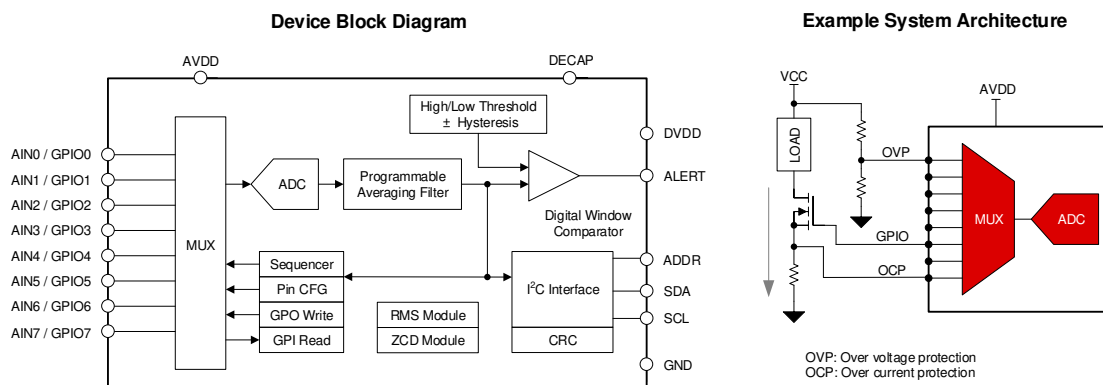

Table of Contents

1 Features	1	8.3 Feature Description.....	14
2 Applications	1	8.4 Device Functional Modes.....	24
3 Description	1	8.5 Programming.....	27
4 Revision History	2	8.6 ADS7128 Registers.....	30
5 Device Comparison Table	3	9 Application and Implementation	74
6 Pin Configuration and Functions	4	9.1 Application Information.....	74
7 Specifications	5	9.2 Typical Applications	74
7.1 Absolute Maximum Ratings	5	10 Power Supply Recommendations	77
7.2 ESD Ratings.....	5	10.1 AVDD and DVDD Supply Recommendations.....	77
7.3 Recommended Operating Conditions.....	5	11 Layout	78
7.4 Thermal Information	5	11.1 Layout Guidelines	78
7.5 Electrical Characteristics.....	6	11.2 Layout Example	78
7.6 I ² C Timing Requirements.....	7	12 Device and Documentation Support	79
7.7 Timing Requirements.....	7	12.1 Receiving Notification of Documentation Updates	79
7.8 I ² C Switching Characteristics.....	7	12.2 Support Resources	79
7.9 Switching Characteristics	8	12.3 Trademarks	79
7.10 Typical Characteristics	9	12.4 Electrostatic Discharge Caution.....	79
8 Detailed Description	13	12.5 Glossary	79
8.1 Overview	13	13 Mechanical, Packaging, and Orderable	79
8.2 Functional Block Diagram	13	Information	79

4 Revision History

NOTE: Page numbers for previous revisions may differ from page numbers in the current version.

Changes from Original (May 2019) to Revision A	Page
• Changed document status from advance information to production data	1

5 Device Comparison Table

PART NUMBER	DESCRIPTION	CRC MODULE	ZERO-CROSSING-DETECT (ZCD) MODULE	ROOT-MEAN-SQUARE (RMS) MODULE
ADS7128	8-channel, 12-bit ADC with I ² C interface and GPIOs	Yes	Yes	Yes
ADS7138		Yes	No	No
ADS7138-Q1		Yes	No	No

6 Pin Configuration and Functions

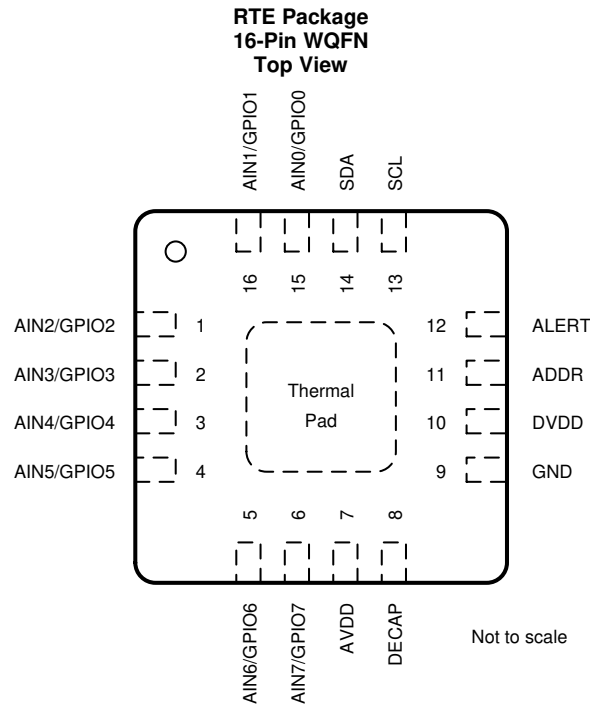

Pin Functions

PIN		FUNCTION ⁽¹⁾	DESCRIPTION
NAME	NO.		
AIN0/GPIO0	15	AI, DI, DO	Channel 0; configurable as either an analog input (default) or a general-purpose input/output (GPIO)
AIN1/GPIO1	16	AI, DI, DO	Channel 1; configurable as either an analog input (default) or a GPIO
AIN2/GPIO2	1	AI, DI, DO	Channel 2; configurable as either an analog input (default) or a GPIO
AIN3/GPIO3	2	AI, DI, DO	Channel 3; configurable as either an analog input (default) or a GPIO
AIN4/GPIO4	3	AI, DI, DO	Channel 4; configurable as either an analog input (default) or a GPIO
AIN5/GPIO5	4	AI, DI, DO	Channel 5; configurable as either an analog input (default) or a GPIO
AIN6/GPIO6	5	AI, DI, DO	Channel 6; configurable as either an analog input (default) or a GPIO
AIN7/GPIO7	6	AI, DI, DO	Channel 7; configurable as either an analog input (default) or a GPIO
ADDR	11	AI	Input for selecting the device I ² C address. Connect a resistor to this pin from DECAP pin or GND to select one of the eight addresses.
ALERT	12	Digital output	Open-drain (default) or push-pull output for the digital comparator
AVDD	7	Supply	Analog supply input, also used as the reference voltage to the ADC; connect a 1- μ F decoupling capacitor to GND
DECAP	8	Supply	Connect a 1- μ F decoupling capacitor between the DECAP and GND pins for the internal power supply
DVDD	10	Supply	Digital I/O supply voltage; connect a 1- μ F decoupling capacitor to GND
GND	9	Supply	Ground for the power supply; all analog and digital signals are referred to this pin voltage
SDA	14	DI, DO	Serial data input or output for the I ² C interface
SCL	13	DI	Serial clock for the I ² C interface
Thermal pad	—	Supply	Exposed thermal pad; connect to GND.

(1) AI = analog input, DI = digital input, and DO = digital output.

7 Specifications

7.1 Absolute Maximum Ratings

over operating ambient temperature range (unless otherwise noted)⁽¹⁾

	MIN	MAX	UNIT
DVDD to GND	-0.3	5.5	V
AVDD to GND	-0.3	5.5	V
AINx/GPOx ⁽²⁾	GND - 0.3	AVDD + 0.3	V
ADDR	GND - 0.3	2.1	V
Digital inputs	GND - 0.3	5.5	V
Current through any pin except supply pins ⁽³⁾	-10	10	mA
Junction temperature, T _J	-40	125	°C
Storage temperature, T _{stg}	-60	150	°C

(1) Stresses beyond those listed under *Absolute Maximum Rating* may cause permanent damage to the device. These are stress ratings only, which do not imply functional operation of the device at these or any other conditions beyond those indicated under *Recommended Operating Condition*. Exposure to absolute-maximum-rated conditions for extended periods may affect device reliability.

(2) AINx/GPIOx refers to pins 1, 2, 3, 4, 5, 6, 15, and 16.

(3) Pin current must be limited to 10mA or less.

7.2 ESD Ratings

			VALUE	UNIT
V _(ESD)	Electrostatic discharge	Human body model (HBM), per ANSI/ESDA/JEDEC JS-001, all pins ⁽¹⁾	±2000	V
		Charged device model (CDM), per JEDEC specification JESD22-C101, all pins ⁽²⁾	±500	

(1) JEDEC document JEP155 states that 500-V HBM allows safe manufacturing with a standard ESD control process.

(2) JEDEC document JEP157 states that 250-V CDM allows safe manufacturing with a standard ESD control process.

7.3 Recommended Operating Conditions

over operating free-air temperature range (unless otherwise noted)

PARAMETER		TEST CONDITIONS	MIN	TYP	MAX	UNIT
POWER SUPPLY						
AVDD	Analog supply voltage		2.35	3.3	5.5	V
DVDD	Digital supply voltage		1.65	3.3	5.5	V
ANALOG INPUTS						
FSR	Full-scale input range	AIN _x ⁽¹⁾ - GND	0		AVDD	V
V _{IN}	Absolute input voltage	AIN _x - GND	-0.1		AVDD + 0.1	V
TEMPERATURE RANGE						
T _A	Ambient temperature		-40	25	85	°C

(1) AINx refers to AIN0, AIN1, AIN2, AIN3, AIN4, AIN5, AIN6, and AIN7.

7.4 Thermal Information

THERMAL METRIC ⁽¹⁾		ADS7128	UNIT
		RTE (WQFN)	
		16 PINS	
R _{θJA}	Junction-to-ambient thermal resistance	49.7	°C/W
R _{θJC(top)}	Junction-to-case (top) thermal resistance	53.4	°C/W
R _{θJB}	Junction-to-board thermal resistance	24.7	°C/W
Ψ _{JT}	Junction-to-top characterization parameter	1.3	°C/W
Ψ _{JB}	Junction-to-board characterization parameter	24.7	°C/W
R _{θJC(bot)}	Junction-to-case (bottom) thermal resistance	9.3	°C/W

(1) For more information about traditional and new thermal metrics, see the [Semiconductor and IC Package Thermal Metrics](#) application report.

7.5 Electrical Characteristics

at AVDD = 2.35 V to 5 V, DVDD = 1.65 V to 5.5 V, and maximum throughput (unless otherwise noted); minimum and maximum values at T_A = –40°C to +85°C; typical values at T_A = 25°C.

PARAMETER		TEST CONDITIONS	MIN	TYP	MAX	UNIT
ANALOG INPUTS						
C _{SH}	Sampling capacitance			12		pF
DC PERFORMANCE						
	Resolution	No missing codes		12		bits
DNL	Differential nonlinearity		–0.75	±0.45	0.75	LSB
INL	Integral nonlinearity		–1.5	±0.5	1.5	LSB
V _(OS)	Input offset error	Post offset calibration	–2	±0.3	2	LSB
	Input offset thermal drift	Post offset calibration		±1		ppm/°C
G _E	Gain error		–0.065	±0.05	0.065	%FSR
	Gain error thermal drift			±1		ppm/°C
AC PERFORMANCE						
SINAD	Signal-to-noise + distortion ratio	AVDD = 5 V, f _{IN} = 2 kHz	70	72.8		dB
		AVDD = 3 V, f _{IN} = 2 kHz	69.8	72.4		
SNR	Signal-to-noise ratio	AVDD = 5 V, f _{IN} = 2 kHz	71.2	73		dB
		AVDD = 3 V, f _{IN} = 2 kHz	70.5	72.5		
	Crosstalk	100-kHz signal applied on any OFF channel and measured on the ON channel		–100		dB
DECAP Pin						
C _{DECAP}	Decoupling capacitor on DECAP pin		0.1	1	4.7	μF
	Voltage output on DECAP pin	C _{DECAP} = 1 μF		1.8		V
DIGITAL INPUT/OUTPUT (SCL, SDA)						
V _{IH}	Input high logic level	All I ² C modes	0.7 x DVDD		5.5	V
V _{IL}	Input low logic level	All I ² C modes	–0.3		0.3 x DVDD	V
V _{OL}	Output low logic level	Sink current = 2 mA, DVDD > 2 V	0		0.4	V
		Sink current = 2 mA, DVDD ≤ 2 V	0		0.2 x DVDD	
I _{OL}	Low-level output current (sink)	V _{OL} = 0.4 V, standard and fast mode			3	mA
		V _{OL} = 0.6 V, fast mode			6	
		V _{OL} = 0.4 V, fast mode plus			20	
GPIOs						
V _{IH}	Input high logic level		0.7 x AVDD		AVDD + 0.3	V
V _{IL}	Input low logic level		–0.3		0.3 x AVDD	V
	Input leakage current	GPIO configured as input		10	100	nA
V _{OH}	Output high logic level	GPO_DRIVE_CFG = push-pull, I _{SOURCE} = 2 mA	0.8 x AVDD		AVDD	V
V _{OL}	Output low logic level	I _{SINK} = 2 mA	0		0.2 x AVDD	V
I _{OH}	Output high source current	V _{OH} > 0.7 x AVDD			5	mA
I _{OL}	Output low sink current	V _{OL} < 0.3 x AVDD			5	mA
DIGITAL OUTPUT (ALERT)						
V _{OH}	Output high logic level	GPO_DRIVE_CFG = push-pull, I _{SOURCE} = 2 mA	0.8 x DVDD		DVDD	V
V _{OL}	Output low logic level	I _{SINK} = 2 mA	0		0.2 x DVDD	V
I _{OH}	Output high sink current	V _{OH} > 0.7 x DVDD			5	mA
I _{OL}	Output low sink current	V _{OL} < 0.3 x DVDD			5	mA
POWER SUPPLY CURRENTS						

Electrical Characteristics (continued)

at AVDD = 2.35 V to 5 V, DVDD = 1.65 V to 5.5 V, and maximum throughput (unless otherwise noted); minimum and maximum values at T_A = –40°C to +85°C; typical values at T_A = 25°C.

PARAMETER		TEST CONDITIONS	MIN	TYP	MAX	UNIT
I _{AVDD}	Analog supply current	I ² C high-speed mode, AVDD = 5 V		155	195	μA
		I ² C fast mode plus, AVDD = 5 V		45	75	
		I ² C fast mode, AVDD = 5 V		29	37	
		I ² C standard mode, AVDD = 5 V		13	18	
		No conversion, AVDD = 5 V		7	15	

7.6 I²C Timing Requirements

		MODE ⁽¹⁾				UNIT
		STANDARD, FAST, AND FAST MODE PLUS		HIGH-SPEED MODE		
		MIN	MAX	MIN	MAX	
f _{SCL}	SCL clock frequency ⁽²⁾	1		3.4		MHz
t _{SUSTA}	START condition setup time for repeated start	260		160		ns
t _{HDSTA}	Start condition hold time	260		160		ns
t _{LOW}	Clock low period	500		160		ns
t _{HIGH}	Clock high period	260		60		ns
t _{SUDAT}	Data in setup time	50		10		ns
t _{HDDAT}	Data in hold time	0		0		ns
t _R	SCL rise time		120		80	ns
t _F	SCL fall time		120		80	ns
t _{SUSTO}	STOP condition hold time	260		60		ns
t _{BUF}	Bus free time before new transmission	500		300		ns

(1) The device supports standard, full-speed, and fast modes by default on power-up. For selecting high-speed mode refer to the section on [Configuring the Device for High-Speed I²C Mode](#).

(2) Bus load (C_B) consideration; C_B ≤ 400 pF for f_{SCL} ≤ 1 MHz; C_B < 100 pF for f_{SCL} = 3.4 MHz.

7.7 Timing Requirements

at AVDD = 2.35 V to 5 V, DVDD = 1.65 V to 5.5 V, and maximum throughput (unless otherwise noted); minimum and maximum values at T_A = –40°C to +85°C; typical values at T_A = 25°C.

		MIN	MAX	UNIT
t _{ACQ}	Acquisition time	300		ns

7.8 I²C Switching Characteristics

		MODE				UNIT
		STANDARD, FAST, AND FAST MODE PLUS		HIGH-SPEED MODE		
		MIN	MAX	MIN	MAX	
t _{VDDATA}	SCL low to SDA data out valid		450		200	ns
t _{VDAK}	SCL low to SDA acknowledge time		450		200	ns
t _{STRETCH}	Clock stretch time in one-shot conversion mode		1400		1000	ns
t _{SP}	Noise suppression time constant on SDA and SCL		50		10	ns

7.9 Switching Characteristics

at AVDD = 2.35 V to 5 V, DVDD = 1.65 V to 5.5 V, and maximum throughput (unless otherwise noted); minimum and maximum values at TA = -40°C to +85°C; typical values at TA = 25°C.

PARAMETER	TEST CONDITIONS	MIN	MAX	UNIT
CONVERSION CYCLE				
t _{CONV}	ADC conversion time		t _{STRETCH}	ns
		Manual and auto sequence modes		
	Autonomous mode		600	ns
RESET AND ALERT				
t _{PU}	Power-up time for device	AVDD ≥ 2.35 V		5 ms
t _{RST}	Delay time; RST bit = 1b to device reset complete ⁽¹⁾			5 ms
t _{ALERT_HI}	ALERT high period	ALERT_LOGIC[1:0] = 1x	50	150 ns
t _{ALERT_LO}	ALERT low period	ALERT_LOGIC[1:0] = 1x	50	150 ns

(1) RST bit is automatically reset to 0b after t_{RST}.

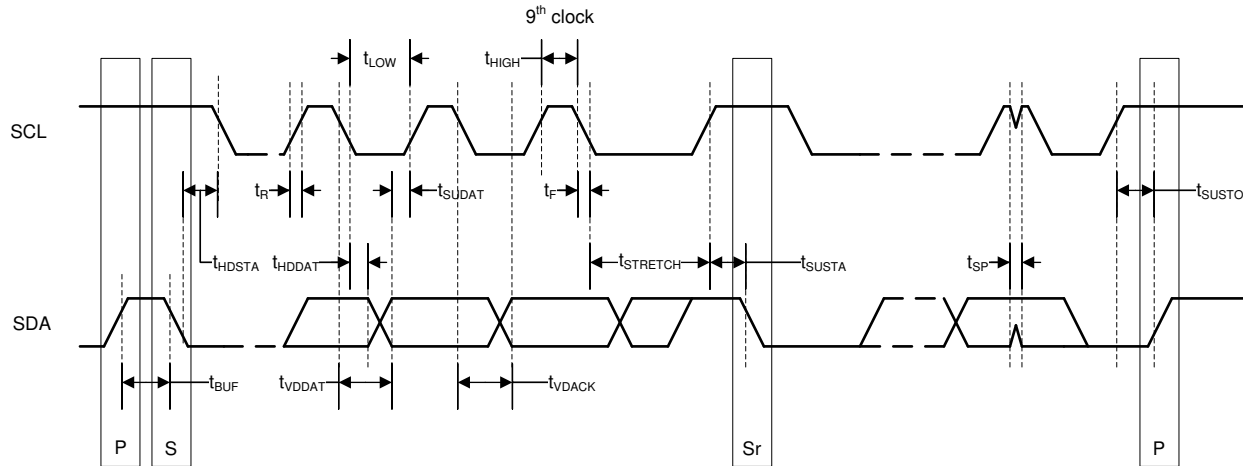

NOTE: S = start, Sr = repeated start, and P = stop.

Figure 1. I²C Timing Diagram

7.10 Typical Characteristics

at $T_A = 25^\circ\text{C}$, $AVDD = 5\text{ V}$, $DVDD = 3.3\text{ V}$, and maximum throughput (unless otherwise noted)

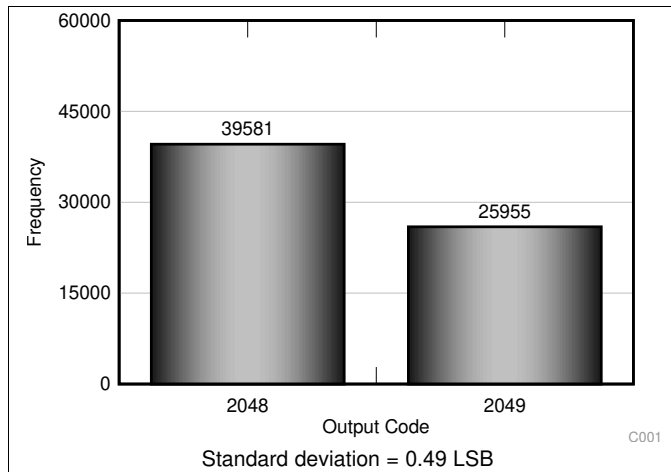

Figure 2. DC Input Histogram

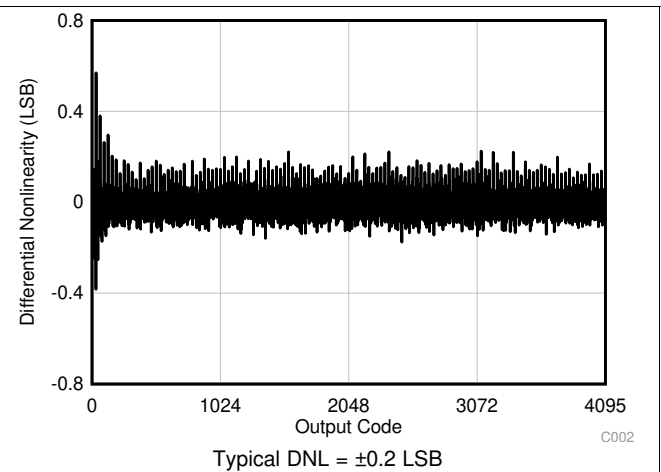

Figure 3. Typical DNL

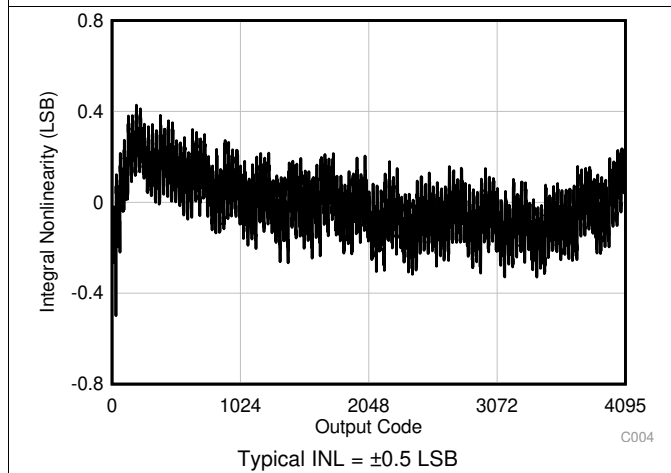

Figure 4. Typical INL

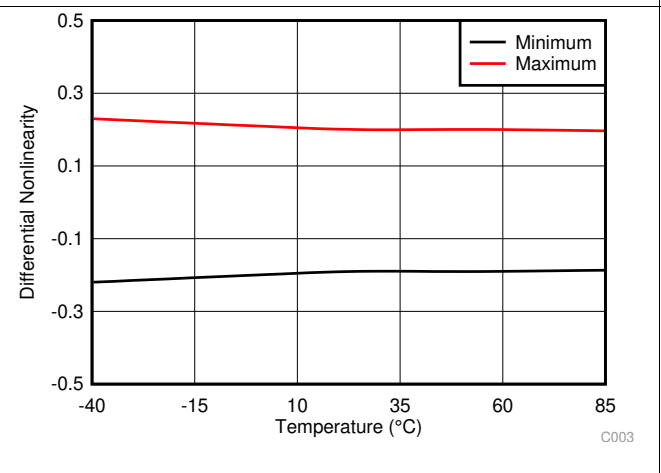

Figure 5. DNL vs Temperature

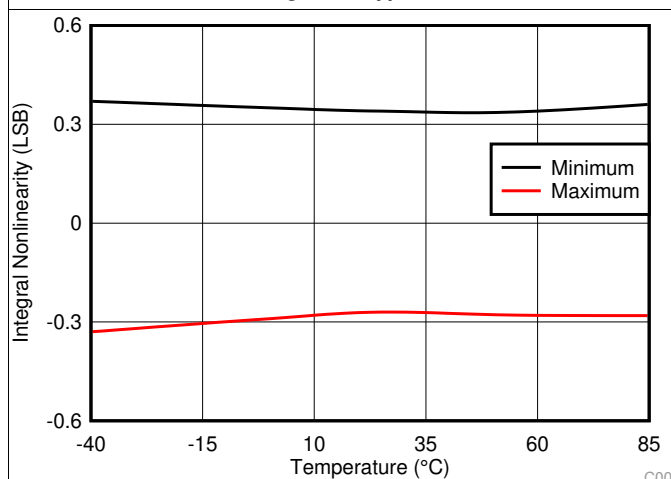

Figure 6. INL vs Temperature

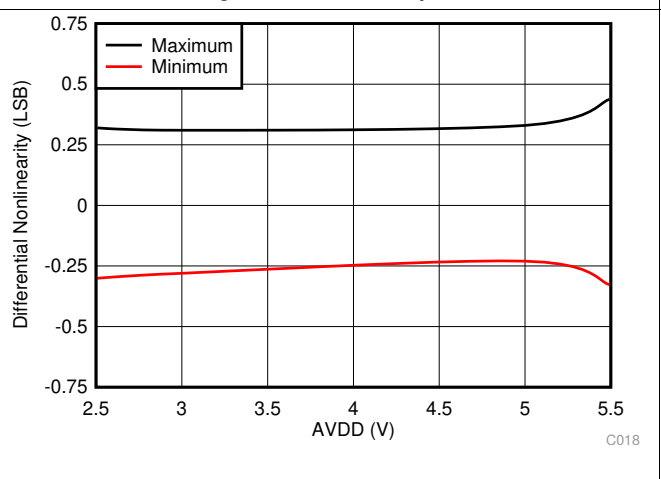
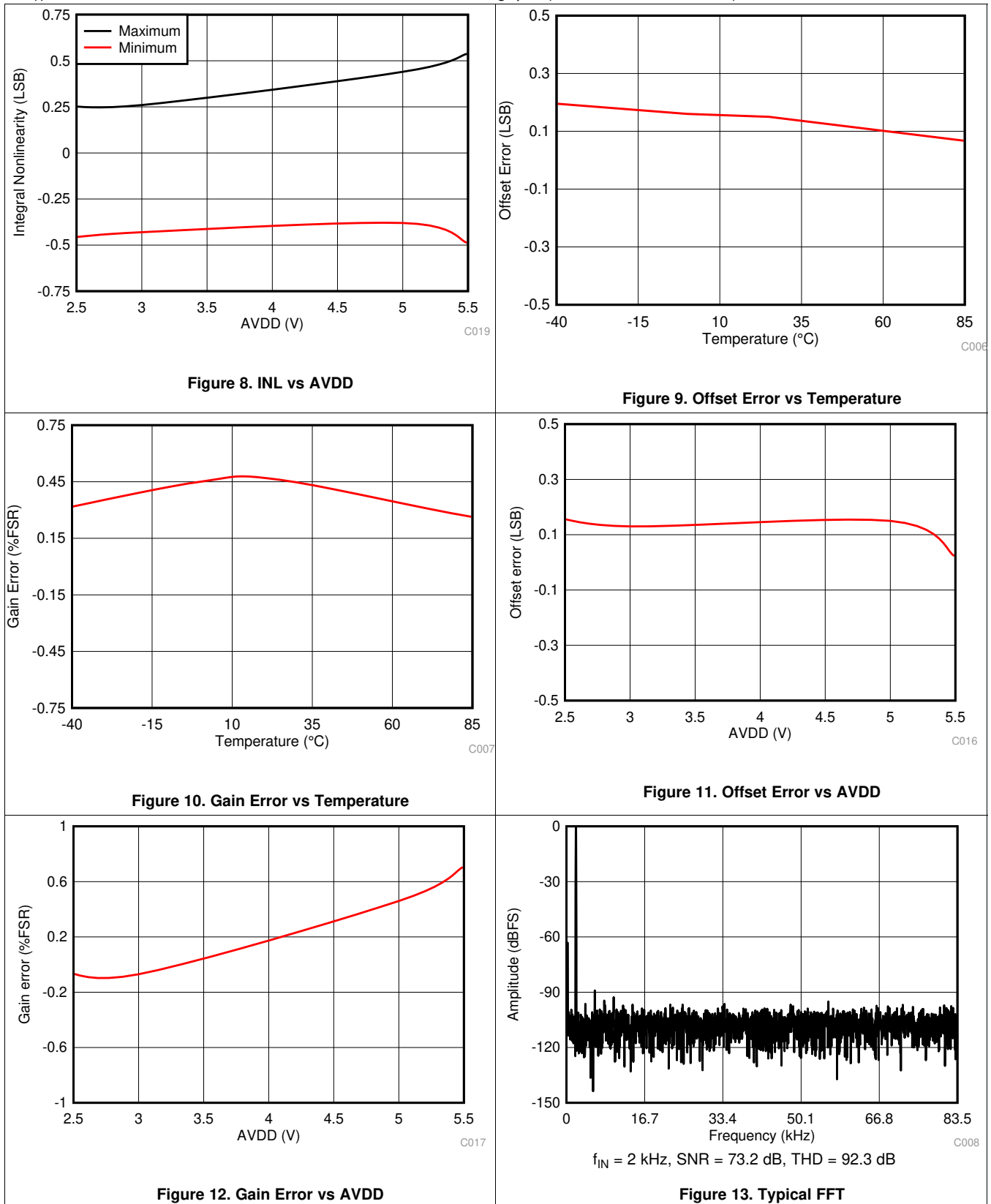

Figure 7. DNL vs AVDD

Typical Characteristics (continued)

at $T_A = 25^\circ\text{C}$, $AVDD = 5\text{ V}$, $DVDD = 3.3\text{ V}$, and maximum throughput (unless otherwise noted)



Typical Characteristics (continued)

at $T_A = 25^\circ\text{C}$, $AVDD = 5\text{ V}$, $DVDD = 3.3\text{ V}$, and maximum throughput (unless otherwise noted)

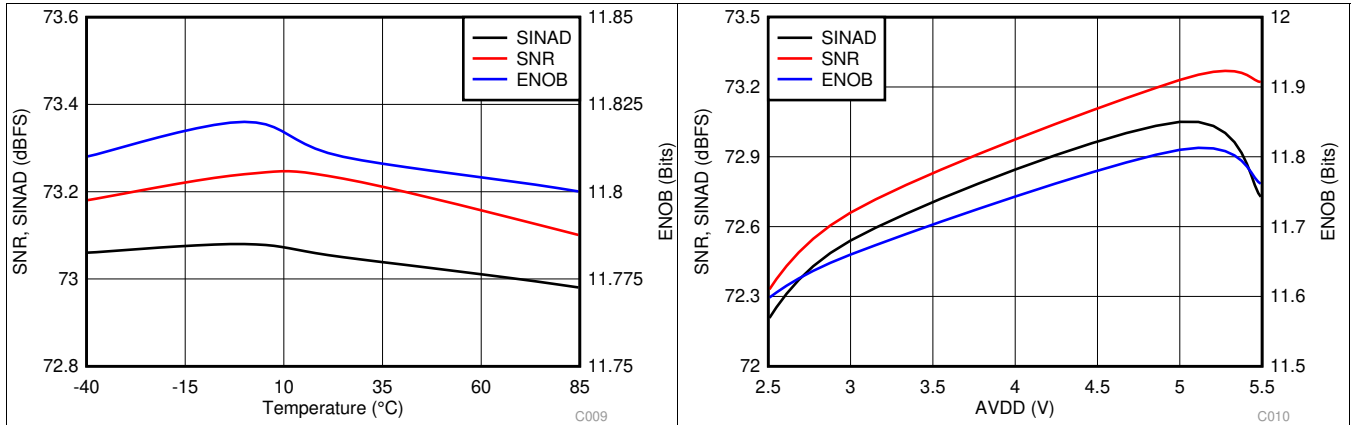

Figure 14. Noise Performance vs Temperature

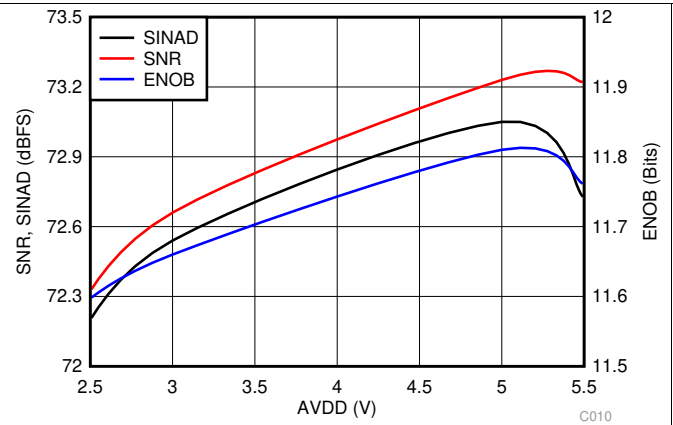

Figure 15. Noise Performance vs AVDD

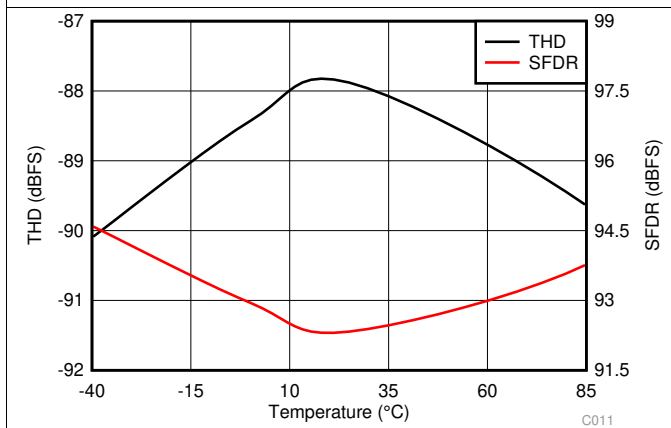

Figure 16. Distortion Performance vs Temperature

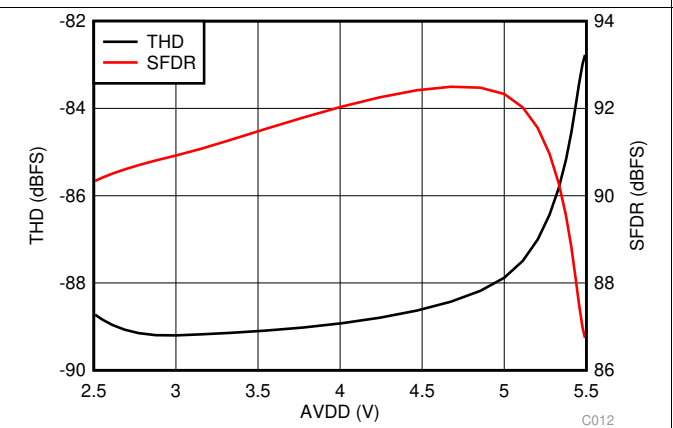

Figure 17. Distortion Performance vs AVDD

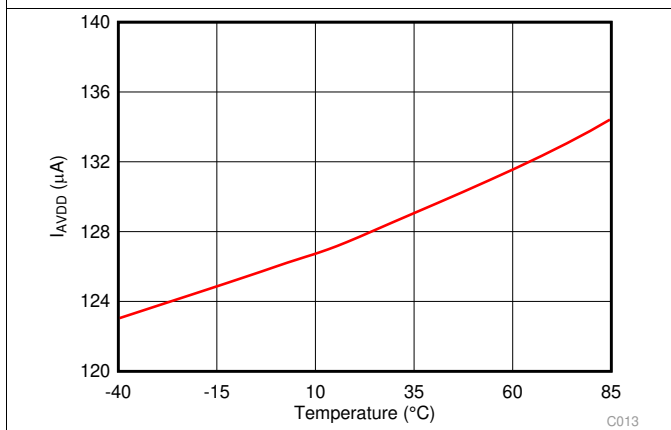

Figure 18. Analog Supply Current vs Temperature

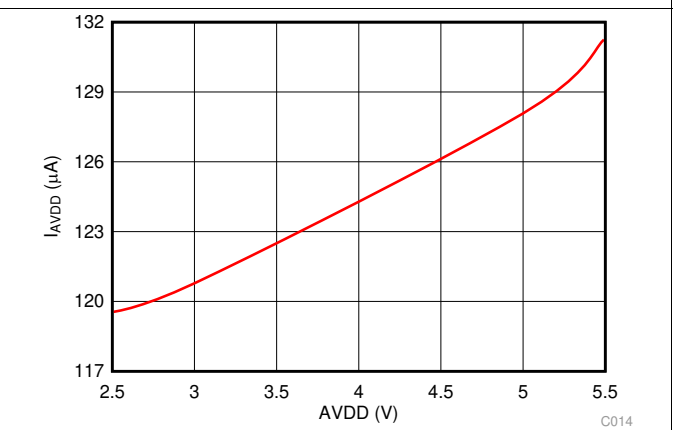

Figure 19. Analog Supply Current vs AVDD

Typical Characteristics (continued)

at $T_A = 25^\circ\text{C}$, $AVDD = 5\text{ V}$, $DVDD = 3.3\text{ V}$, and maximum throughput (unless otherwise noted)

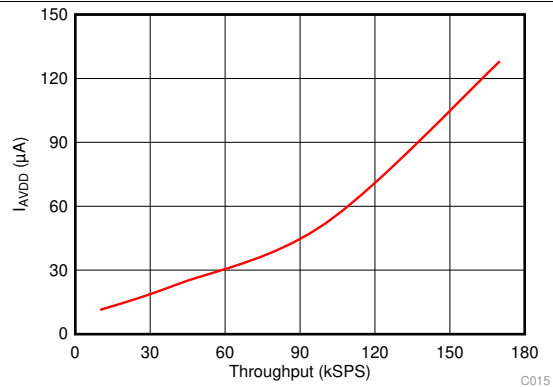

Figure 20. Analog Supply Current vs Throughput

8 Detailed Description

8.1 Overview

The ADS7128 is a small, eight-channel, multiplexed, 12-bit, analog-to-digital converter (ADC) with an I²C-compatible serial interface. The eight channels of the ADS7128 can be individually configured as either analog inputs, digital inputs, or digital outputs. The device includes a digital comparator with a dedicated alert pin that can be used to interrupt the host when a programmed high or low threshold is crossed on any input channel. The device uses an internal oscillator for conversion. The ADC can be used in the manual mode for reading ADC data over the I²C interface or in autonomous mode for monitoring the analog inputs without an active I²C interface.

The device features a programmable averaging filter that outputs a 16-bit result for enhanced resolution. The root-mean-square (RMS) module computes a 16-bit true RMS result of any analog input channel over a configurable time window. The zero-crossing-detect (ZCD) module can be used to generate a digital output corresponding to the programmable threshold crossings of any analog input channel.

The I²C serial interface supports standard-mode, fast-mode, fast-mode plus, and high-speed mode. The device also features an 8-bit cyclic redundancy check (CRC) for the serial communication interface.

8.2 Functional Block Diagram

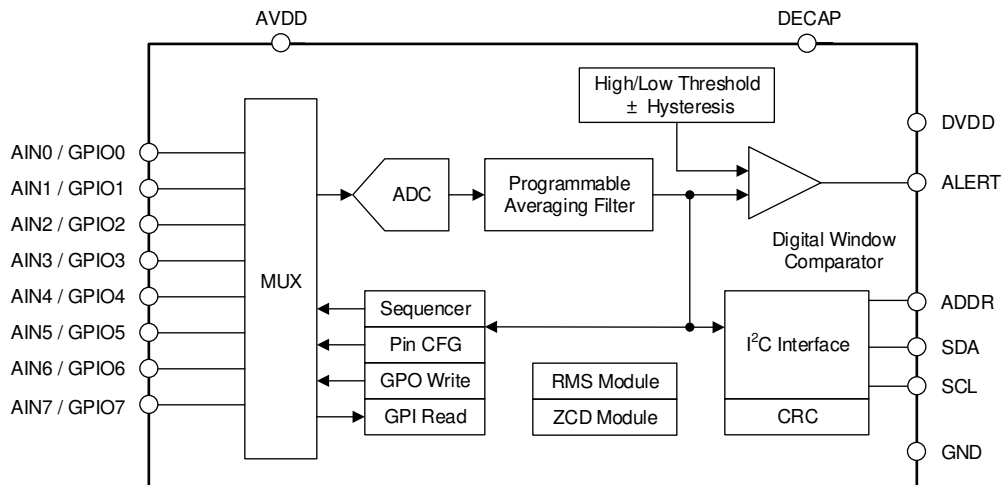

8.3 Feature Description

8.3.1 Multiplexer and ADC

The eight channels of the multiplexer can be independently configured as ADC inputs or general-purpose inputs/outputs (GPIOs). [Figure 21](#) shows that each input pin has electrostatic discharge (ESD) protection diodes to AVDD and GND. On power-up or after device reset, all eight multiplexer channels are configured as analog inputs.

[Figure 21](#) shows an equivalent circuit for pins configured as analog inputs. The ADC sampling switch is represented by an ideal switch (SW) in series with the resistor, R_{SW} (typically 150 Ω), and the sampling capacitor, C_{SH} (typically 12 pF).

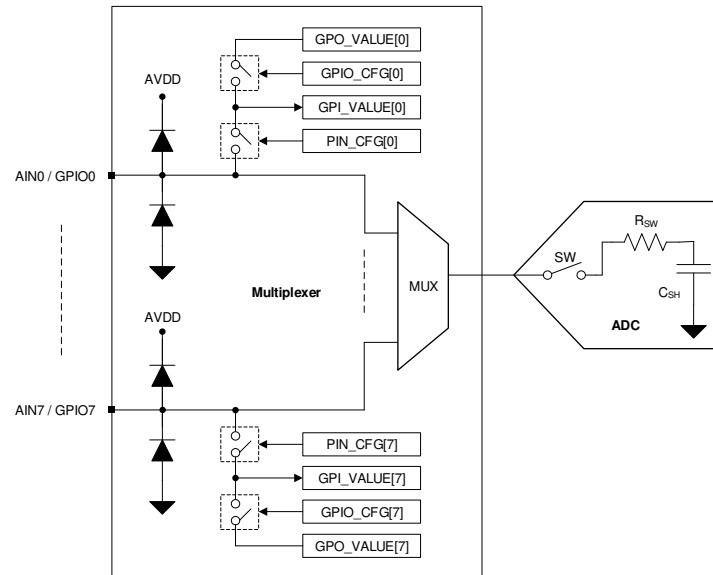

Figure 21. Analog Inputs, GPIOs, and ADC Connections

During acquisition, the SW switch is closed to allow the signal on the selected analog input channel to charge the internal sampling capacitor. During conversion, the SW switch is opened to disconnect the analog input channel from the sampling capacitor.

The multiplexer channels can be configured as GPIOs in the PIN_CFG register. The direction of a GPIO (either as an input or an output) can be set in the GPIO_CFG register. The logic level on the channels configured as digital I/O can be read from the GPI_VALUE register. The digital outputs can be accessed by writing to the GPO_VALUE register. The digital outputs can be configured as either open-drain or push-pull in the GPO_DRIVE_CFG register.

8.3.2 Reference

The device uses the analog supply voltage (AVDD) as a reference for the analog-to-digital conversion process. TI recommends connecting a 1- μ F, low-equivalent series resistance (ESR) ceramic decoupling capacitor between the AVDD and GND pins.

8.3.3 ADC Transfer Function

The ADC output is in straight binary format. [Equation 1](#) computes the ADC resolution:

$$1 \text{ LSB} = V_{REF} / 2^N$$

where:

- $V_{REF} = AVDD$
- $N = 12$

(1)

[Figure 22](#) and [Table 1](#) detail the transfer characteristics for the device.

Feature Description (continued)

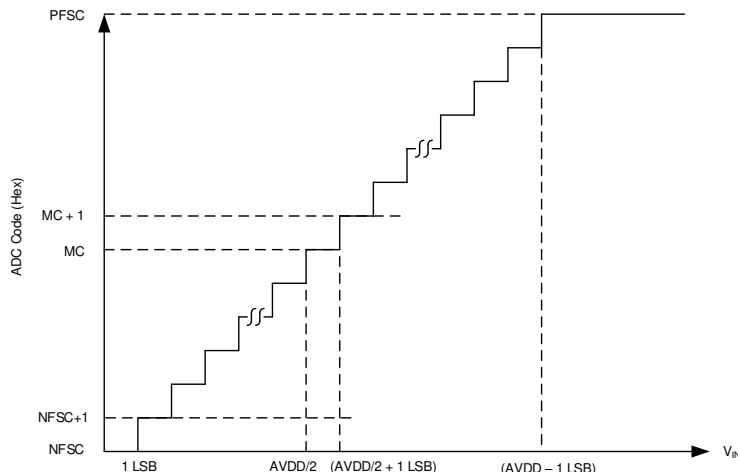

Figure 22. Ideal Transfer Characteristics

Table 1. Transfer Characteristics

INPUT VOLTAGE	CODE	DESCRIPTION	IDEAL OUTPUT CODE
≤ 1 LSB	NFSC	Negative full-scale code	000
1 LSB to 2 LSBs	NFSC + 1	—	001
$(AVDD / 2)$ to $(AVDD / 2) + 1$ LSB	MC	Mid code	800
$(AVDD / 2) + 1$ LSB to $(AVDD / 2) + 2$ LSB	MC + 1	—	801
$\geq AVDD - 1$ LSB	PFSC	Positive full-scale code	FFF

8.3.4 ADC Offset Calibration

The variation in ADC offset error resulting from changes in temperature or AVDD can be calibrated by setting the CAL bit in the GENERAL_CFG register. The CAL bit is reset to 0 after calibration. The host can poll the CAL bit to check the ADC offset calibration completion status.

8.3.5 I²C Address Selector

The I²C address for the device is determined by connecting external resistors on the ADDR pin. The device address is determined at power-up based on the resistor values. The device retains this address until the next power-up event, until the next device reset, or until the device receives a command to program its own address. Figure 23 shows a connection diagram for the ADDR pin and Table 2 lists the resistor values for selecting different addresses of the device.

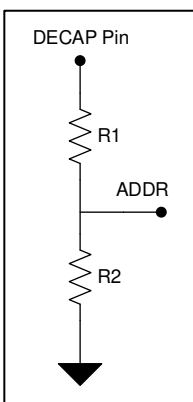

Figure 23. External Resistor Connection Diagram for the ADDR Pin

Table 2. I²C Address Selection

RESISTORS		ADDRESS
R1 ⁽¹⁾	R2 ⁽¹⁾	
0 Ω	DNP ⁽²⁾	001 0111b (17h)
11 kΩ	DNP ⁽²⁾	001 0110b (16h)
33 kΩ	DNP ⁽²⁾	001 0101b (15h)
100 kΩ	DNP ⁽²⁾	001 0100b (14h)
DNP ⁽²⁾	DNP ⁽²⁾	001 0000b (10h)
DNP ⁽²⁾	11 kΩ	001 0001b (11h)
DNP ⁽²⁾	33 kΩ	001 0010b (12h)
DNP ⁽²⁾	100 kΩ	001 0011b (13h)

- (1) Tolerance for R1, R2 ≤ ±5%.
- (2) DNP = Do not populate.

8.3.6 Programmable Averaging Filter

The ADS7128 features a built-in oversampling (OSR) function that can be used to average several samples. The averaging filter can be enabled by programming the OSR[2:0] bits in the OSR_CFG register. The averaging filter configuration is common to all analog input channels. Figure 24 shows that the averaging filter module output is 16 bits long. In the manual conversion mode and auto-sequence mode, only the first conversion for the selected analog input channel must be initiated by the host; see the *Manual Mode* and *Auto-Sequence Mode* sections. As shown in Figure 24, any remaining conversions for the selected averaging factor are generated internally. The time required to complete the averaging operation is determined by the sampling speed and number of samples to be averaged. As shown in Figure 24, the 16-bit result can be read out after the averaging operation completes.

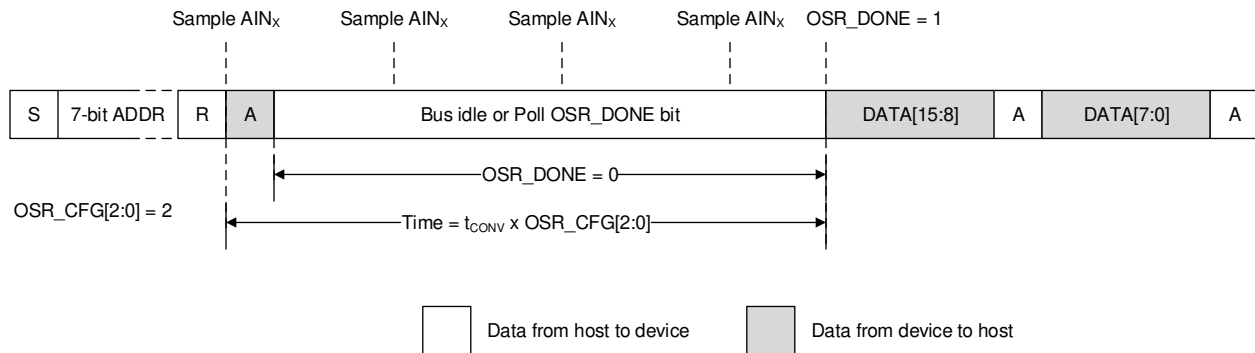

Figure 24. Averaging Example

In Figure 24, SCL is stretched by the device after the start of conversions until the averaging operation is complete.

If SCL stretching is not required during averaging, enable the statistics registers by setting STATS_EN to 1b and initiate conversions by writing 1b to the CNVST bit. The OSR_DONE bit in the SYSTEM_STATUS register can be polled to check the averaging completion status. When using the CNVST bit to initiate conversion, the result can be read in the RECENT_CHx_LSB and RECENT_CHx_MSB registers.

In the autonomous mode of operation, samples from the analog input channels that are enabled in the AUTO_SEQ_CH_SEL register are averaged sequentially; see the *Autonomous Mode* section. The digital window comparator compares the top 12 bits of the 16-bit average result with the thresholds.

Equation 2 provides the LSB value of the 16-bit average result.

$$1 \text{ LSB} = \frac{AVDD}{2^{16}} \tag{2}$$

8.3.7 CRC on Data Interface

The ADS7128 features a cyclic redundancy check (CRC) module for checking the integrity of the data bits exchanged over the I²C interface. The CRC module is bidirectional and appends an 8-bit CRC to every byte read from the device while also evaluating the CRC of every incoming byte over the I²C interface. The CRC module uses the CRC-8-CCITT polynomial ($x^8 + x^2 + x + 1$) for CRC computation.

To enable the CRC module, set the CRC_EN bit in the GENERAL_CFG register. [Table 3](#) shows how a CRC error can be detected when configuring the ADS7128.

Table 3. Configuration Notifications When a CRC Error is Detected

CRC ERROR NOTIFICATION	CONFIGURATION	DESCRIPTION
ALERT pin	ALERT_CRCIN = 1b	ALERT pin is asserted if a CRC error is detected by the device.
Status flags	APPEND_STATUS = 10b	4-bit status flags are appended to the ADC data; see the Output Data Format section for details.
Register read	—	Read the CRC_ERR_IN bit to check if a CRC error is detected.

When the ADS7128 detects a CRC error, the erroneous data are ignored and the CRC_ERR_IN bit is set. [Table 3](#) describes the additional notifications that can be enabled. Further register writes are disabled until the CRC_ERR_IN bit is cleared by writing 1b to it. When using autonomous mode, further conversions can be disabled on the CRC error by setting CONV_ON_ERR to 1b; see the [Autonomous Mode](#) section.

8.3.8 General-Purpose I/Os (GPIOs)

The eight channels of the ADS7128 can be independently configured as analog inputs, digital inputs, or digital outputs. [Table 4](#) describes how the PIN_CFG and GPIO_CFG registers can be used to configure the channels.

Table 4. Configuring Channels as Analog Inputs or GPIOs

PIN_CFG[7:0]	GPIO_CFG[7:0]	GPO_DRIVE_CFG[7:0]	CHANNEL CONFIGURATION
0	x	x	Analog input (default)
1	0	x	Digital input
1	1	0	Digital output; open-drain driver
1	1	1	Digital output; push-pull driver

The digital outputs can be configured to logic 1 or 0 by writing to the GPO_VALUE register. Reading the GPI_VALUE register returns the logic level for all channels configured as digital inputs.

8.3.9 Oscillator and Timing Control

The device uses an internal oscillator for conversions. When using the averaging module or the RMS module, the host initiates the first conversion and all subsequent conversions are generated internally by the device. However, in the autonomous mode of operation, the start of the conversion signal is generated by the device. [Table 5](#) shows that when the device generates the start of the conversion, the sampling rate is controlled by the OSC_SEL and CLK_DIV[3:0] register fields.

Table 5. Configuring Sampling Rate for Internal Conversion Start Control

CLK_DIV[3:0]	OSC_SEL = 0		OSC_SEL = 1	
	SAMPLING FREQUENCY, f_{CYCLE} (kSPS)	CYCLE TIME, t_{CYCLE} (μs)	SAMPLING FREQUENCY, f_{CYCLE} (kSPS)	CYCLE TIME, t_{CYCLE} (μs)
0000b	1000	1	31.25	32
0001b	666.7	1.5	20.83	48
0010b	500	2	15.63	64
0011b	333.3	3	10.42	96
0100b	250	4	7.81	128
0101b	166.7	6	5.21	192
0110b	125	8	3.91	256
0111b	83	12	2.60	384
1000b	62.5	16	1.95	512
1001b	41.7	24	1.3	768
1010b	31.3	32	0.98	1024
1011b	20.8	48	0.65	1536
1100b	15.6	64	0.49	2048
1101b	10.4	96	0.33	3072
1110b	7.8	128	0.24	4096
1111b	5.2	192	0.16	6144

The conversion time of the device (see t_{CONV} in the [Switching Characteristics](#) table) is independent of the OSC_SEL and CLK_DIV[3:0] configuration.

8.3.10 Output Data Format

[Figure 25](#) illustrates various I²C frames for reading data.

- Read the ADC conversion result: Two 8-bit I²C packets are required (frame A).
- Read the averaged conversion result: Two 8-bit I²C packets are required (frame B).
- Read data with the channel ID or status flags appended: The 4-bit channel ID or status flags can be appended to the 12-bit ADC result by configuring the APPEND_STATUS field in the GENERAL_CFG register. The status flags can be used to detect if a CRC error is detected and if an alert condition is detected by the digital window comparator. When the channel ID or status flags are appended to the 12-bit ADC data, two I²C packets are required (frame C). If the channel ID or status flags are appended to the 16-bit average result, three I²C frames are required (frame D).

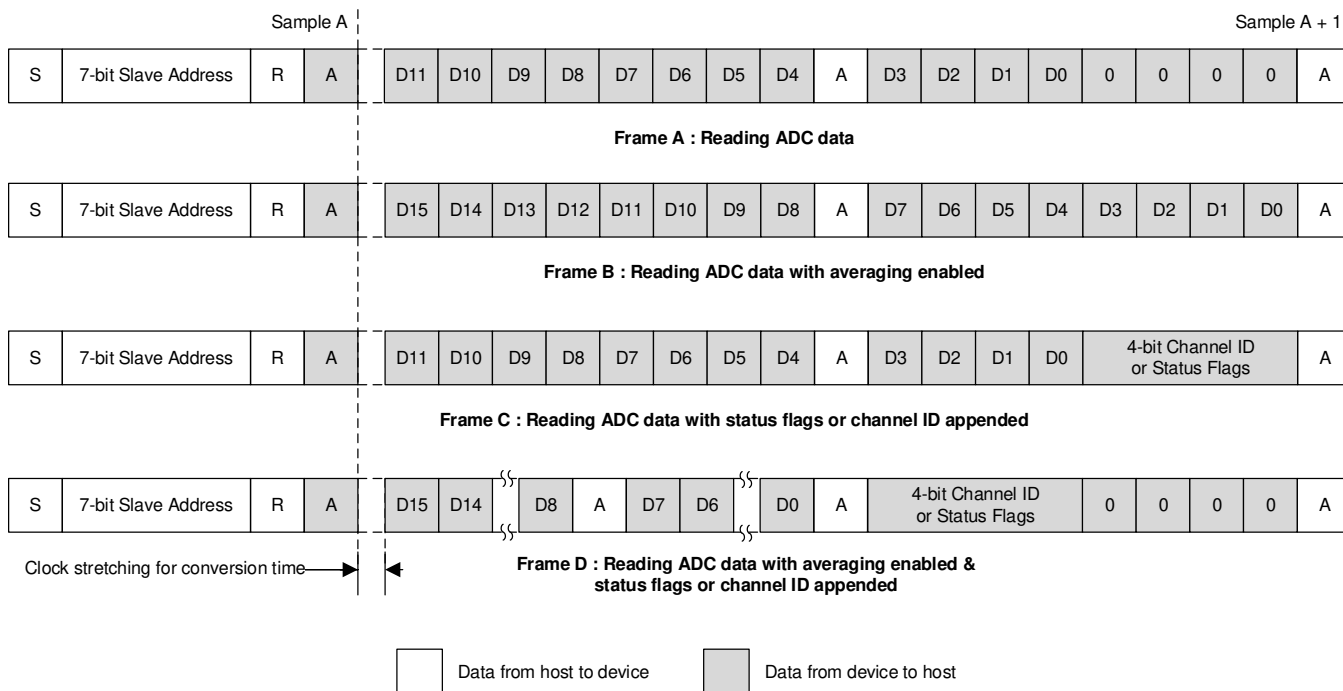

Figure 25. Data Frames for Reading Data

When status flags are enabled, APPEND_STATUS is set to 10b and four bits are appended to the ADC output. The device outputs status flags in this order: {1b, 0b, CRCERR_IN, ALERT}. The level transitions on the digital interface, resulting from the fixed 1b and 0b in the status flags, can be used to detect if the digital outputs are shorted to a fixed voltage in the system. The CRCERR_IN flag reflects the corresponding bit in the GENERAL_CFG register. The ALERT flag is the output of the logical OR of the bits in the EVENT_FLAG register.

8.3.11 Digital Window Comparator

The internal digital window comparator (DWC) is available in all functional modes of the device (see the *Device Functional Modes* section for details). The digital window comparator controls output of the ALERT pin buffer. The ALERT pin can be configured as open-drain (default) or push-pull output using the ALERT_DRIVE bit in the ALERT_PIN_CFG register. Figure 26 shows a block diagram for the digital window comparator.

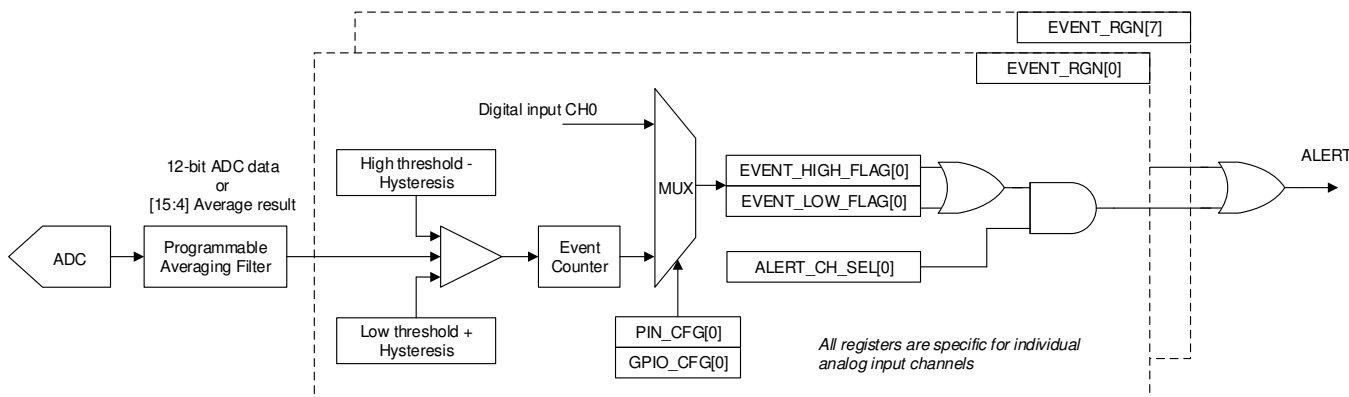

Figure 26. Digital Window Comparator Block Diagram

The low-side threshold, high-side threshold, event counter, and hysteresis parameters are independently programmable for each input channel. Figure 27 shows the events that can be monitored for every analog input channel by the window comparator.

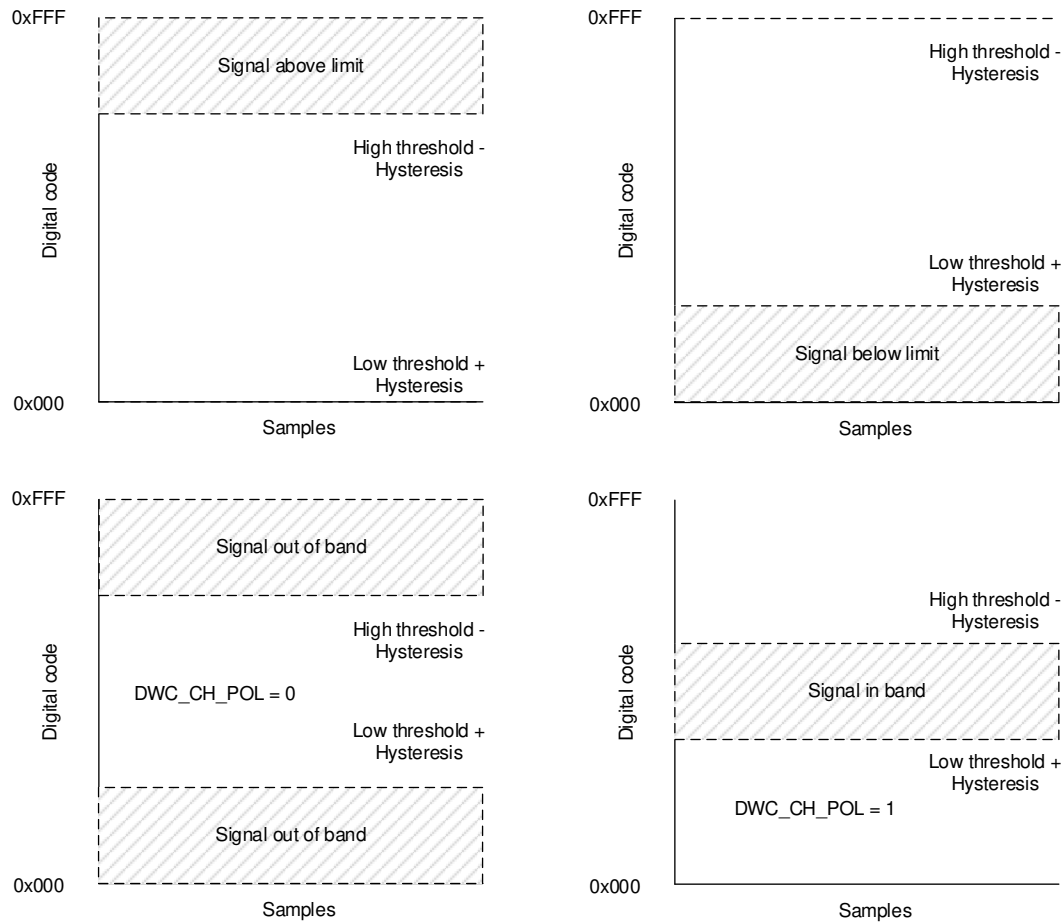

Figure 27. Event Monitoring With the Window Comparator

To enable the digital window comparator, set the `DWC_EN` bit in the `GENERAL_CFG` register. By default, hysteresis is 0, the high threshold is 0xFFFF, and the low threshold is 0x000. A 12-bit straight binary code cannot be higher than 0xFFFF or lower than 0x000, thus the thresholds have no effect unless set to different values. Figure 27 shows the various types of event that can be detected by adjusting the thresholds. For detecting when a signal is in-band, the `EVENT_RGN` register must be configured. In each of the cases shown in Figure 27, either or both `EVENT_HIGH_FLAG` and `EVENT_LOW_FLAG` can be set.

The programmable event counter counts consecutive thresholds violations before alert flags can be set. The event count can be set to a higher value to avoid transients in the input signal setting the alert flags.

In order to assert the `ALERT` pin when the alert flag is set for a particular analog input channel, set the corresponding bit in the `ALERT_CH_SEL` register. Alert flags are set regardless of the `ALERT_CH_SEL` configuration if `DWC_EN` is 1 and the high or low thresholds are exceeded.

8.3.11.1 Interrupts From Digital Inputs

Logic 1 or logic 0 events can be detected on channels configured as digital inputs, as shown in Table 6, by enabling the corresponding ALERT_CH_SEL bit.

Table 6. Configuring Interrupts From Digital Inputs

PIN_CFG[7:0]	GPIO_CFG[7:0]	ALERT_CH_SEL[7:0]	EVENT_RGN [7:0]	EVENT DESCRIPTION
1	0	1	0	EVENT_HIGH_FLAG is set when digital input channel is at logic 1.
1	0	1	1	EVENT_LOW_FLAG is set when digital input channel is at logic 0.

8.3.11.2 Changing Digital Outputs on Alert and ZCD

Figure 28 shows how digital outputs can be updated in response to alerts from individual channels or synchronized to the zero-crossing-detect signal.

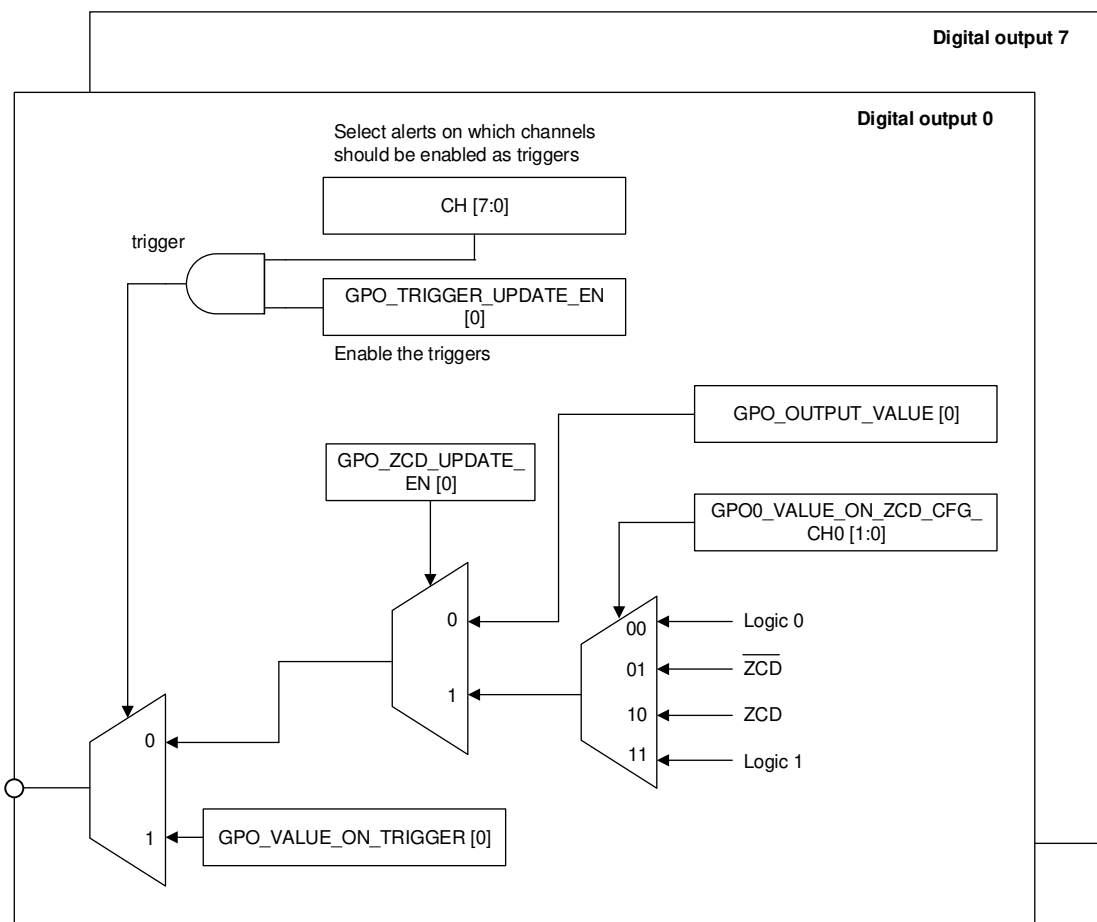

Figure 28. Block Diagram for the Digital Output Logic

8.3.11.2.1 Changing Digital Outputs on Alerts

Any given digital output can be updated in response to an alert condition on one or more analog inputs and digital inputs. To update the digital output in response to alert conditions, the trigger must be configured and the value must be launched on the trigger.

8.3.11.2.1.1 Trigger

The following events can act as triggers for updating the value on the digital output:

- An alert occurs on one or more analog input channels. The digital window comparator must be enabled for these channels.
- An alert occurs on one or more digital input channels. The digital window comparator must be enabled for these channels.

Configure the GPOx_TRIG_EVENT_SEL register to select which channels, analog inputs, or digital inputs can trigger an update on the digital output pin. After configuring the triggers for updating a digital output, the logic can be enabled by configuring the corresponding bit in the GPO_TRIGGER_UPDATE_EN register.

8.3.11.2.1.2 Output Value

The digital outputs can be set to logic 1 or logic 0 in response to the triggers. The value to be updated on the digital output when a trigger event occurs can be configured in the GPO_VALUE_ON_TRIGGER register.

8.3.11.2.2 Changing Digital Outputs Synchronous to the Zero-Crossing Detect

Individual digital outputs can be set to either logic 0, logic 1, ZCD, or $\overline{\text{ZCD}}$ synchronous to the zero-crossing-detect signal. This function can be enabled for individual digital outputs by configuring the GPO_VALUE_ON_ZCD_CFG_CHx field and setting the corresponding bit in the GPO_ZCD_UPDATE_EN [7:0] register.

8.3.12 Root-Mean-Square Module

The ADS7128 features an RMS computation module. Any one analog input channel can be selected for computing the RMS result. The RMS result is computed over a block of samples from the selected channel and the result can be read from the RMS_RESULT_LSB and RMS_RESULT_MSB registers. Equation 3 shows how the RMS result is computed by calculating the 16-bit square root of the mean of the accumulated result of the squares of the ADC conversion data.

$$RMS = \sqrt{\underbrace{\left(\frac{D_1^2 + D_2^2 + D_3^2 + \dots + D_N^2}{N} \right)}_{\text{AC component}} - b \times \underbrace{\left(\frac{D_1 + D_2 + D_3 + \dots + D_N}{N} \right)^2}_{\text{DC component}}} \text{ LSB}$$

where

- D is the data corresponding to the analog input channel selected for RMS measurement
- N is the number of samples over which the RMS is computed

The DC offset must be subtracted from the AC component because the analog input signal to the ADC is unipolar. DC subtraction can be enabled or disabled, as given by b in Equation 3, by configuring the DC_SUB field. When DC subtraction is enabled, the DC input voltage must be within $\pm 5\%$ tolerance of the mid-scale voltage i.e. $(0.5 \times AVDD) \pm 5\%$.

The RMS result is 16 bits long and Equation 4 gives the size of the 1 LSB of RMS result.

$$1 \text{ LSB} = AVDD / 2^{16} \quad (4)$$

The procedure for using the RMS module is outlined in the steps below:

1. Select the channel for the RMS computation using the RMS_CHID field in the RMS_CFG register.
2. Define the time over which the RMS is to be computed by configuring the RMS_SAMPLES field.
3. Start the RMS computation by setting RMS_EN to 1 in the GENERAL_CFG register.
4. The device starts computing the RMS result when the sample size defined by RMS_SAMPLES is converted on the analog input selected for RMS computation. An additional 40 samples must be converted to complete the RMS computation.
5. To monitor for when the RMS computation completes, poll the RMS_DONE bit in the SYSTEM_STATUS register. The ALERT pin can also be used for requesting an interrupt by configuring the ALERT_RMS bit in the ALERT_MAP register.

6. For starting a new RMS measurement, write 1 to the RMS_EN bit in the GENERAL_CFG register.

8.3.13 Zero-Crossing-Detect Module

Figure 29 shows the zero-crossing-detection (ZCD) module that generates a digital output corresponding to the threshold crossings of an analog input. In order to detect threshold crossings on a particular analog input, configure the 4-bit channel ID in the ZCD_CHID register field. The threshold crossing to be detected can be configured in the HIGH_TH register. The output of the ZCD module can be mapped to any digital output by configuring the GPO_ZCD_UPDATE_EN, GPO_VALUE_ZCD_CFG_CH0_CH3, and GPO_VALUE_ZCD_CFG_CH4_CH7 registers.

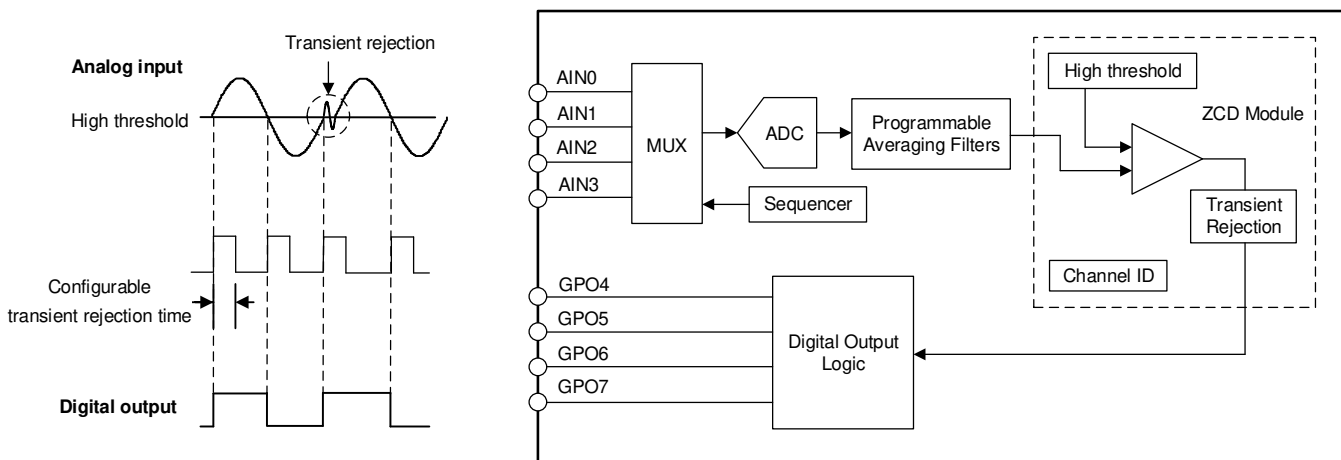

Figure 29. ZCD Module Operation Block Diagram

The ADC conversion result of the selected analog input channel is compared with the digital threshold and the digital output is set accordingly. Equation 5 shows how transients near zero crossings can be rejected by configuring the ZCD_BLANKING register.

$$\text{transient rejection time} = \text{MULT_EN} \times \text{ZCD_BLANKING}[6:0] \times \frac{1}{\text{sampling rate for ZCD channel}} \text{seconds} \quad (5)$$

8.3.14 Minimum, Maximum, and Latest Data Registers

The ADS7128 can record the minimum, maximum, and latest code (statistics registers) for every analog input channel. To enable or re-enable recording statistics, set the STATS_EN bit in the GENERAL_CFG register. Writing 1 to the STATS_EN bit reinitializes the statistics module, after which results from new conversions are recorded in the statistics registers. Until a new conversion result is available, previous values can be read from the statistics registers. Before reading the statistics registers, set STATS_EN to 0 to prevent any updates to this register block.

8.3.15 I²C Protocol Features

8.3.15.1 General Call

On receiving a general call (00h), the device provides an acknowledge (ACK).

8.3.15.2 General Call With Software Reset

On receiving a general call (00h) followed by a software reset (06h), the device resets itself.

8.3.15.3 General Call With a Software Write to the Programmable Part of the Slave Address

On receiving a general call (00h) followed by 04h, the device reevaluates its own I²C address configured by the ADDR pin. During this operation, the device does not respond to other I²C commands except the general-call command.

8.3.15.4 Configuring the Device for High-Speed I²C Mode

The device can be configured in high-speed I²C mode by providing an I²C frame with one of these codes: 0x09, 0x0B, 0x0D, or 0x0F.

After receiving one of these codes, the device sets the I2C_HIGH_SPEED bit in the SYSTEM_STATUS register and remains in high-speed I²C mode until a STOP condition is received in an I²C frame.

8.4 Device Functional Modes

Table 7 lists the functional modes supported by the ADS7128.

Table 7. Functional Modes

FUNCTIONAL MODE	CONVERSION CONTROL	MUX CONTROL	CONV_MODE[1:0]	SEQ_MODE[1:0]
Manual	9th falling edge of SCL (ACK)	Register write to MANUAL_CHID	00b	00b
Auto-sequence	9th falling edge of SCL (ACK)	Channel sequencer	00b	01b
Autonomous	Internal to the device	Channel sequencer	01b	01b

The device powers up in manual mode (see the [Manual Mode](#) section) and can be configured into any mode listed in Table 7 by writing the configuration registers for the desired mode.

8.4.1 Device Power-Up and Reset

On power-up, the device calculates the address from the resistors connected on the ADDR pin and the BOR bit is set, thus indicating a power-cycle or reset event.

The device can be reset by an I²C general call (00h) followed by a software reset (06h), by setting the RST bit, or by recycling the power on the AVDD pin.

8.4.2 Manual Mode

Manual mode allows the external host processor to directly select the analog input channel. Figure 30 lists the steps for operating the device in manual mode.

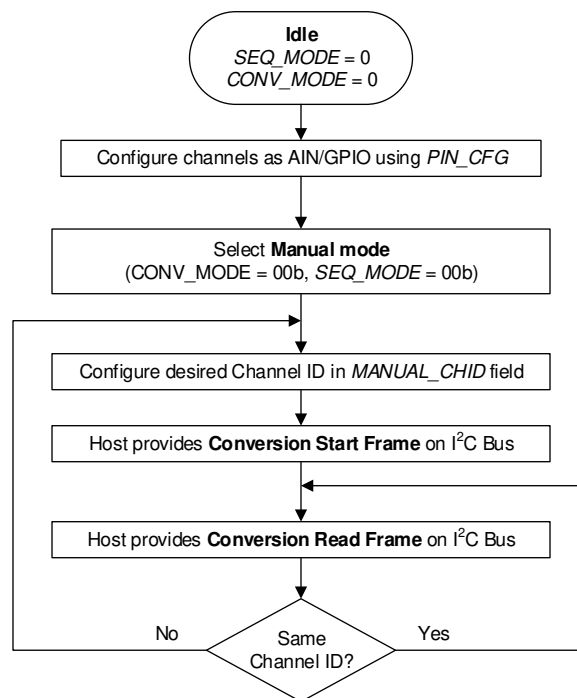

Manual mode with channel selection using register write

Figure 30. Device Operation in Manual Mode

Provide an I²C start or restart frame to initiate a conversion, as shown in the conversion start frame of Figure 31, after configuring the device registers. ADC data can be read in subsequent I²C frames. The number of I²C frames required to read conversion data depends on the output data frame size; see the *Output Data Format* section for more details. A new conversion is initiated on the ninth falling edge of SCL (ACK bit) when the last byte of output data is read.

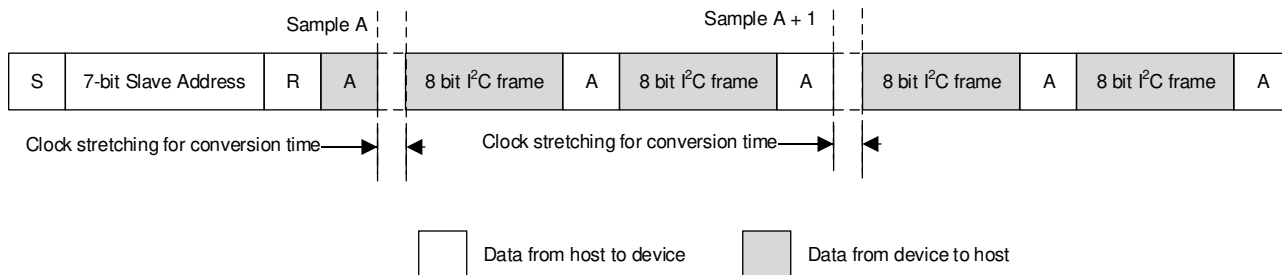

Figure 31. Starting a Conversion and Reading Data in Manual Mode

8.4.3 Auto-Sequence Mode

In auto-sequence mode, the internal channel sequencer switches the multiplexer to the next analog input channel after every conversion. The desired analog input channels can be configured for sequencing in the AUTO_SEQ_CHSEL register. To enable the channel sequencer, set SEQ_START to 1b. After every conversion, the channel sequencer switches the multiplexer to the next analog input in ascending order. To stop the channel sequencer from selecting channels, set SEQ_START to 0b. Figure 32 lists the conversion start and read frames for auto-sequence mode.

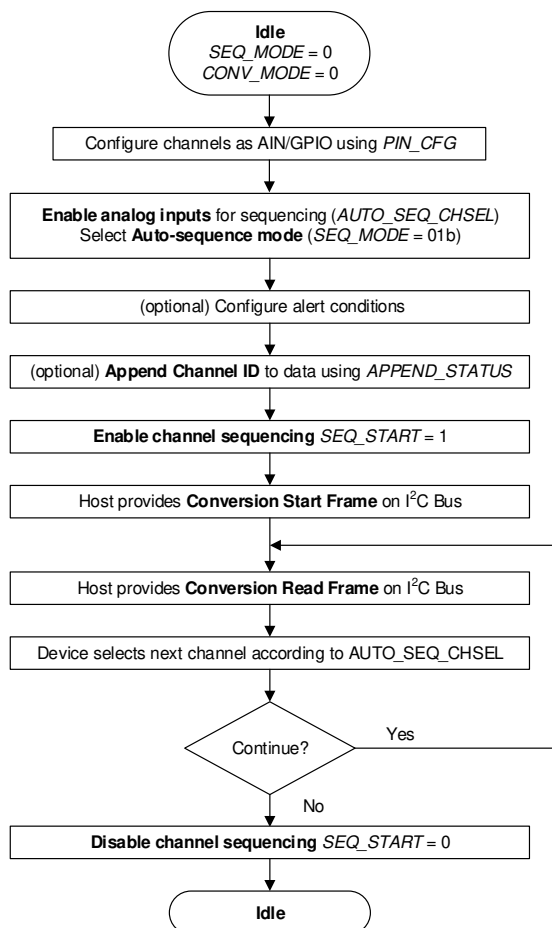

Figure 32. Device Operation in Auto-Sequence Mode

8.4.4 Autonomous Mode

In autonomous mode, the device can be programmed to monitor the voltage applied on the analog input pins of the device and generate a signal on the ALERT pin when the programmable high or low threshold values are crossed. In this mode, the device generates the start of conversion using the internal oscillator. The first start of conversion must be provided by the host and the device then generates the subsequent start of conversions.

Figure 33 shows the steps for configuring the operation mode to autonomous mode. Abort the ongoing sequence by setting SEQ_START to 0b before changing the functional mode or device configuration.

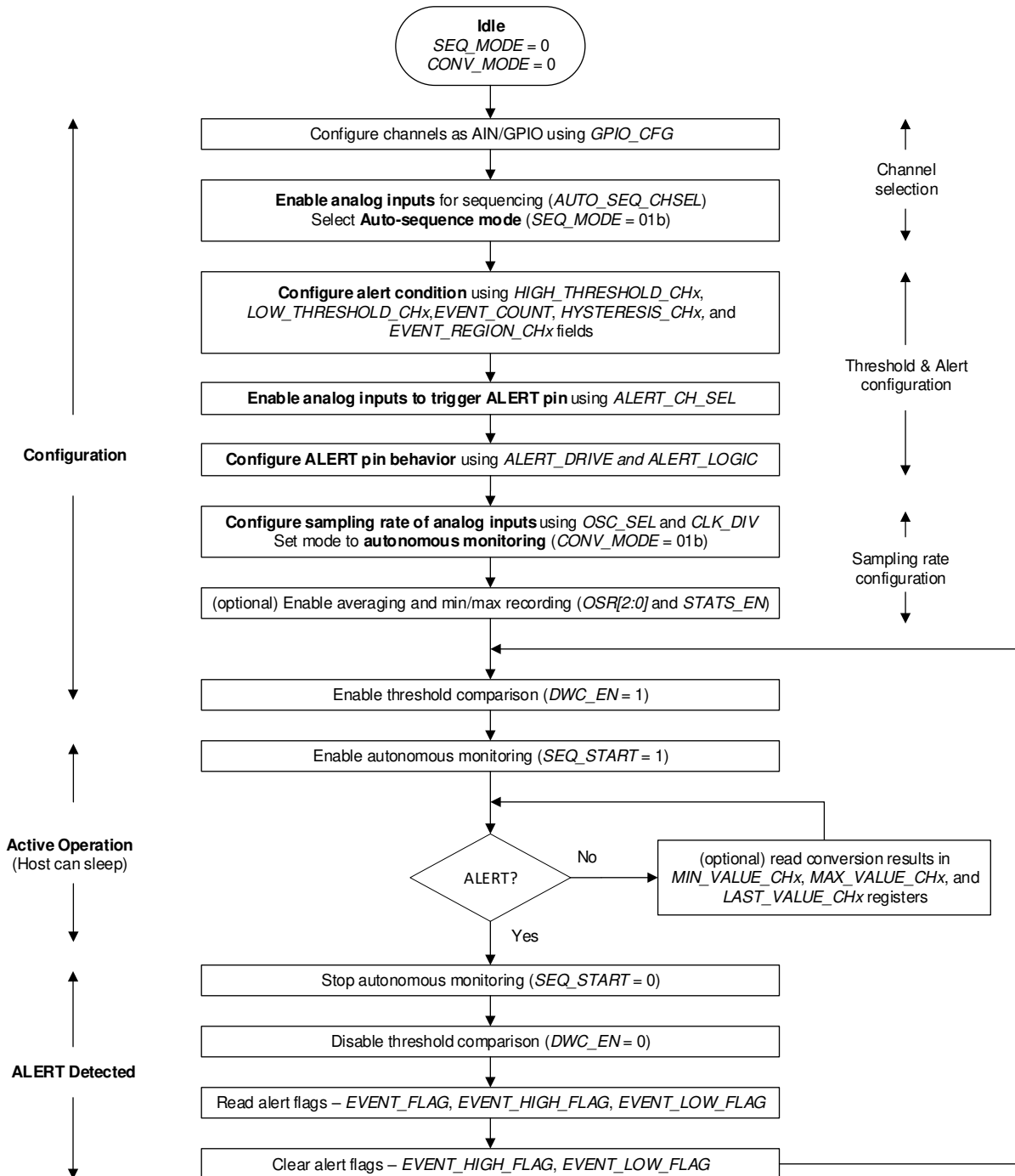

Figure 33. Configuring the Device in Autonomous Mode

8.5 Programming

Table 8 provides the acronyms for different conditions in an I²C frame. Table 9 lists the various command opcodes.

Table 8. I²C Frame Acronyms

SYMBOL	DESCRIPTION
S	Start condition for the I ² C frame
Sr	Restart condition for the I ² C frame
P	Stop condition for the I ² C frame
A	ACK (low)
N	NACK (high)
R	Read bit (high)
W	Write bit (low)

Table 9. Opcodes for Commands

OPCODE	COMMAND DESCRIPTION
0001 0000b	Single register read
0000 1000b	Single register write
0001 1000b	Set bit
0010 0000b	Clear bit
0011 0000b	Reading a continuous block of registers
0010 1000b	Writing a continuous block of registers

8.5.1 Reading Registers

The I²C master can either read a single register or a continuous block registers from the device, as described in the *Single Register Read* and *Reading a Continuous Block of Registers* sections.

8.5.1.1 Single Register Read

To read a single register from the device, the I²C master must provide an I²C command with three frames to set the register address for reading data. Table 9 lists the opcodes for different commands. After this command is provided, the I²C master must provide another I²C frame (as shown in Figure 34) containing the device address and the read bit. After this frame, the device provides the register data. The device provides the same register data even if the host provides more clocks. To end the register read command, the master must provide a STOP or a RESTART condition in the I²C frame.



NOTE: S = start, Sr = repeated start, and P = stop.

Figure 34. Reading Register Data

8.5.1.2 Reading a Continuous Block of Registers

To read a continuous block of registers, the I²C master must provide an I²C command to set the register address. The register address is the address of the first register in the block that must be read. After this command is provided, the I²C master must provide another I²C frame, as shown in Figure 35, containing the device address and the read bit. After this frame, the device provides the register data. The device provides data for the next register when more clocks are provided. When data are read from addresses that do not exist in the register map of the device, the device returns zeros. If the device does not have any further registers to provide data on, the device provide zeros. To end the register read command, the master must provide a STOP or a RESTART condition in the I²C frame.

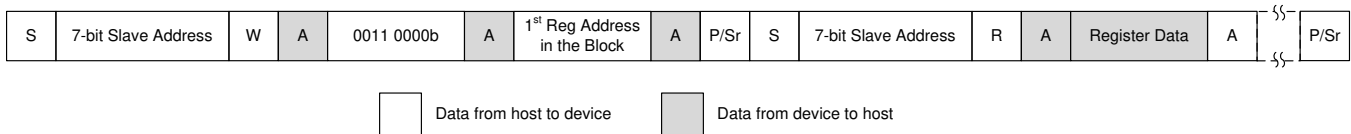

NOTE: S = start, Sr = repeated start, and P = stop.

Figure 35. Reading a Continuous Block of Registers

8.5.2 Writing Registers

The I²C master can either write a single register or a continuous block of registers to the device, set a few bits in a register, or clear a few bits in a register.

8.5.2.1 Single Register Write

To write a single register from the device, as shown in Figure 36, the I²C master must provide an I²C command with four frames. The register address is the address of the register that must be written and the register data is the value that must be written. Table 9 lists the opcodes for different commands. To end the register write command, the master must provide a STOP or a RESTART condition in the I²C frame.

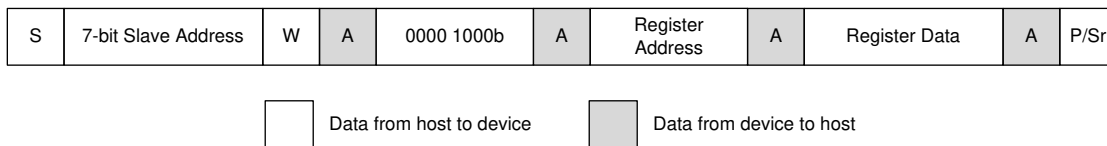

NOTE: S = start, Sr = repeated start, and P = stop.

Figure 36. Writing a Single Register

8.5.2.2 Set Bit

The I²C master must provide an I²C command with four frames, as shown in Figure 36, to set bits in a register without changing the other bits. The register address is the address of the register that the bits must set and the register data is the value representing the bits that must be set. Bits with a value of 1 in the register data are set and bits with a value of 0 in the register data are not changed. Table 9 lists the opcodes for different commands. To end this command, the master must provide a STOP or RESTART condition in the I²C frame.

8.5.2.3 Clear Bit

The I²C master must provide an I²C command with four frames, as shown in Figure 36, to clear bits in a register without changing the other bits. The register address is the address of the register that the bits must clear and the register data is the value representing the bits that must be cleared. Bits with a value of 1 in the register data are cleared and bits with a value of 0 in the register data are not changed. Table 9 lists the opcodes for different commands. To end this command, the master must provide a STOP or a RESTART condition in the I²C frame.

8.5.2.4 Writing a Continuous Block of Registers

The I²C master must provide an I²C command, as shown in Figure 37, to write a continuous block of registers. The register address is the address of the first register in the block that must be written. The I²C master must provide data for registers in subsequent I²C frames in an ascending order of register addresses. Writing data to addresses that do not exist in the register map of the device have no effect. Table 9 lists the opcodes for different commands. If the data provided by the I²C master exceeds the address space of the device, the device ignores the data beyond the address space. To end the register write command, the master must provide a STOP or a RESTART condition in the I²C frame.

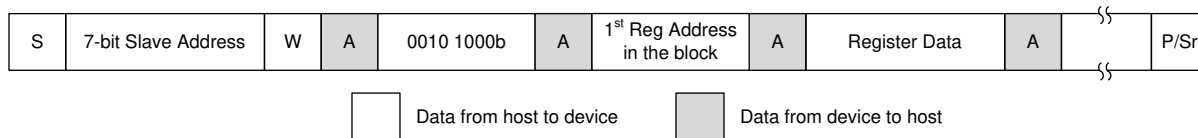

NOTE: S = start, Sr = repeated start, and P = stop.

Figure 37. Writing a Continuous Block of Registers

8.6 ADS7128 Registers

Table 10 lists the ADS7128 registers. All register offset addresses not listed in Table 10 should be considered as reserved locations and the register contents should not be modified.

Table 10. ADS7128 Registers

Address	Acronym	Register Name	Section
0x0	SYSTEM_STATUS	SYSTEM_STATUS Register (Address = 0x0) [reset = 0x81]	
0x1	GENERAL_CFG	GENERAL_CFG Register (Address = 0x1) [reset = 0x0]	
0x2	DATA_CFG	DATA_CFG Register (Address = 0x2) [reset = 0x0]	
0x3	OSR_CFG	OSR_CFG Register (Address = 0x3) [reset = 0x0]	
0x4	OPMODE_CFG	OPMODE_CFG Register (Address = 0x4) [reset = 0x0]	
0x5	PIN_CFG	PIN_CFG Register (Address = 0x5) [reset = 0x0]	
0x7	GPIO_CFG	GPIO_CFG Register (Address = 0x7) [reset = 0x0]	
0x9	GPO_DRIVE_CFG	GPO_DRIVE_CFG Register (Address = 0x9) [reset = 0x0]	
0xB	GPO_VALUE	GPO_VALUE Register (Address = 0xB) [reset = 0x0]	
0xD	GPI_VALUE	GPI_VALUE Register (Address = 0xD) [reset = 0x0]	
0xF	ZCD_BLANKING_CFG	ZCD_BLANKING_CFG Register (Address = 0xF) [reset = 0x0]	
0x10	SEQUENCE_CFG	SEQUENCE_CFG Register (Address = 0x10) [reset = 0x0]	
0x11	CHANNEL_SEL	CHANNEL_SEL Register (Address = 0x11) [reset = 0x0]	
0x12	AUTO_SEQ_CH_SEL	AUTO_SEQ_CH_SEL Register (Address = 0x12) [reset = 0x0]	
0x14	ALERT_CH_SEL	ALERT_CH_SEL Register (Address = 0x14) [reset = 0x0]	
0x16	ALERT_MAP	ALERT_MAP Register (Address = 0x16) [reset = 0x0]	
0x17	ALERT_PIN_CFG	ALERT_PIN_CFG Register (Address = 0x17) [reset = 0x0]	
0x18	EVENT_FLAG	EVENT_FLAG Register (Address = 0x18) [reset = 0x0]	
0x1A	EVENT_HIGH_FLAG	EVENT_HIGH_FLAG Register (Address = 0x1A) [reset = 0x0]	
0x1C	EVENT_LOW_FLAG	EVENT_LOW_FLAG Register (Address = 0x1C) [reset = 0x0]	
0x1E	EVENT_RGN	EVENT_RGN Register (Address = 0x1E) [reset = 0x0]	
0x20	HYSTERESIS_CH0	HYSTERESIS_CH0 Register (Address = 0x20) [reset = 0xF0]	
0x21	HIGH_TH_CH0	HIGH_TH_CH0 Register (Address = 0x21) [reset = 0xFF]	
0x22	EVENT_COUNT_CH0	EVENT_COUNT_CH0 Register (Address = 0x22) [reset = 0x0]	
0x23	LOW_TH_CH0	LOW_TH_CH0 Register (Address = 0x23) [reset = 0x0]	
0x24	HYSTERESIS_CH1	HYSTERESIS_CH1 Register (Address = 0x24) [reset = 0xF0]	
0x25	HIGH_TH_CH1	HIGH_TH_CH1 Register (Address = 0x25) [reset = 0xFF]	
0x26	EVENT_COUNT_CH1	EVENT_COUNT_CH1 Register (Address = 0x26) [reset = 0x0]	
0x27	LOW_TH_CH1	LOW_TH_CH1 Register (Address = 0x27) [reset = 0x0]	
0x28	HYSTERESIS_CH2	HYSTERESIS_CH2 Register (Address = 0x28) [reset = 0xF0]	
0x29	HIGH_TH_CH2	HIGH_TH_CH2 Register (Address = 0x29) [reset = 0xFF]	
0x2A	EVENT_COUNT_CH2	EVENT_COUNT_CH2 Register (Address = 0x2A) [reset = 0x0]	
0x2B	LOW_TH_CH2	LOW_TH_CH2 Register (Address = 0x2B) [reset = 0x0]	
0x2C	HYSTERESIS_CH3	HYSTERESIS_CH3 Register (Address = 0x2C) [reset = 0xF0]	
0x2D	HIGH_TH_CH3	HIGH_TH_CH3 Register (Address = 0x2D) [reset = 0xFF]	
0x2E	EVENT_COUNT_CH3	EVENT_COUNT_CH3 Register (Address = 0x2E) [reset = 0x0]	
0x2F	LOW_TH_CH3	LOW_TH_CH3 Register (Address = 0x2F) [reset = 0x0]	
0x30	HYSTERESIS_CH4	HYSTERESIS_CH4 Register (Address = 0x30) [reset = 0xF0]	
0x31	HIGH_TH_CH4	HIGH_TH_CH4 Register (Address = 0x31) [reset = 0xFF]	
0x32	EVENT_COUNT_CH4	EVENT_COUNT_CH4 Register (Address = 0x32) [reset = 0x0]	
0x33	LOW_TH_CH4	LOW_TH_CH4 Register (Address = 0x33) [reset = 0x0]	
0x34	HYSTERESIS_CH5	HYSTERESIS_CH5 Register (Address = 0x34) [reset = 0xF0]	
0x35	HIGH_TH_CH5	HIGH_TH_CH5 Register (Address = 0x35) [reset = 0xFF]	

Table 10. ADS7128 Registers (continued)

Address	Acronym	Register Name	Section
0x36	EVENT_COUNT_CH5	EVENT_COUNT_CH5 Register (Address = 0x36) [reset = 0x0]	
0x37	LOW_TH_CH5	LOW_TH_CH5 Register (Address = 0x37) [reset = 0x0]	
0x38	HYSTERESIS_CH6	HYSTERESIS_CH6 Register (Address = 0x38) [reset = 0xF0]	
0x39	HIGH_TH_CH6	HIGH_TH_CH6 Register (Address = 0x39) [reset = 0xFF]	
0x3A	EVENT_COUNT_CH6	EVENT_COUNT_CH6 Register (Address = 0x3A) [reset = 0x0]	
0x3B	LOW_TH_CH6	LOW_TH_CH6 Register (Address = 0x3B) [reset = 0x0]	
0x3C	HYSTERESIS_CH7	HYSTERESIS_CH7 Register (Address = 0x3C) [reset = 0xF0]	
0x3D	HIGH_TH_CH7	HIGH_TH_CH7 Register (Address = 0x3D) [reset = 0xFF]	
0x3E	EVENT_COUNT_CH7	EVENT_COUNT_CH7 Register (Address = 0x3E) [reset = 0x0]	
0x3F	LOW_TH_CH7	LOW_TH_CH7 Register (Address = 0x3F) [reset = 0x0]	
0x60	MAX_CH0_LSB	MAX_CH0_LSB Register (Address = 0x60) [reset = 0x0]	
0x61	MAX_CH0_MSB	MAX_CH0_MSB Register (Address = 0x61) [reset = 0x0]	
0x62	MAX_CH1_LSB	MAX_CH1_LSB Register (Address = 0x62) [reset = 0x0]	
0x63	MAX_CH1_MSB	MAX_CH1_MSB Register (Address = 0x63) [reset = 0x0]	
0x64	MAX_CH2_LSB	MAX_CH2_LSB Register (Address = 0x64) [reset = 0x0]	
0x65	MAX_CH2_MSB	MAX_CH2_MSB Register (Address = 0x65) [reset = 0x0]	
0x66	MAX_CH3_LSB	MAX_CH3_LSB Register (Address = 0x66) [reset = 0x0]	
0x67	MAX_CH3_MSB	MAX_CH3_MSB Register (Address = 0x67) [reset = 0x0]	
0x68	MAX_CH4_LSB	MAX_CH4_LSB Register (Address = 0x68) [reset = 0x0]	
0x69	MAX_CH4_MSB	MAX_CH4_MSB Register (Address = 0x69) [reset = 0x0]	
0x6A	MAX_CH5_LSB	MAX_CH5_LSB Register (Address = 0x6A) [reset = 0x0]	
0x6B	MAX_CH5_MSB	MAX_CH5_MSB Register (Address = 0x6B) [reset = 0x0]	
0x6C	MAX_CH6_LSB	MAX_CH6_LSB Register (Address = 0x6C) [reset = 0x0]	
0x6D	MAX_CH6_MSB	MAX_CH6_MSB Register (Address = 0x6D) [reset = 0x0]	
0x6E	MAX_CH7_LSB	MAX_CH7_LSB Register (Address = 0x6E) [reset = 0x0]	
0x6F	MAX_CH7_MSB	MAX_CH7_MSB Register (Address = 0x6F) [reset = 0x0]	
0x80	MIN_CH0_LSB	MIN_CH0_LSB Register (Address = 0x80) [reset = 0xFF]	
0x81	MIN_CH0_MSB	MIN_CH0_MSB Register (Address = 0x81) [reset = 0xFF]	
0x82	MIN_CH1_LSB	MIN_CH1_LSB Register (Address = 0x82) [reset = 0xFF]	
0x83	MIN_CH1_MSB	MIN_CH1_MSB Register (Address = 0x83) [reset = 0xFF]	
0x84	MIN_CH2_LSB	MIN_CH2_LSB Register (Address = 0x84) [reset = 0xFF]	
0x85	MIN_CH2_MSB	MIN_CH2_MSB Register (Address = 0x85) [reset = 0xFF]	
0x86	MIN_CH3_LSB	MIN_CH3_LSB Register (Address = 0x86) [reset = 0xFF]	
0x87	MIN_CH3_MSB	MIN_CH3_MSB Register (Address = 0x87) [reset = 0xFF]	
0x88	MIN_CH4_LSB	MIN_CH4_LSB Register (Address = 0x88) [reset = 0xFF]	
0x89	MIN_CH4_MSB	MIN_CH4_MSB Register (Address = 0x89) [reset = 0xFF]	
0x8A	MIN_CH5_LSB	MIN_CH5_LSB Register (Address = 0x8A) [reset = 0xFF]	
0x8B	MIN_CH5_MSB	MIN_CH5_MSB Register (Address = 0x8B) [reset = 0xFF]	
0x8C	MIN_CH6_LSB	MIN_CH6_LSB Register (Address = 0x8C) [reset = 0xFF]	
0x8D	MIN_CH6_MSB	MIN_CH6_MSB Register (Address = 0x8D) [reset = 0xFF]	
0x8E	MIN_CH7_LSB	MIN_CH7_LSB Register (Address = 0x8E) [reset = 0xFF]	
0x8F	MIN_CH7_MSB	MIN_CH7_MSB Register (Address = 0x8F) [reset = 0xFF]	
0xA0	RECENT_CH0_LSB	RECENT_CH0_LSB Register (Address = 0xA0) [reset = 0x0]	
0xA1	RECENT_CH0_MSB	RECENT_CH0_MSB Register (Address = 0xA1) [reset = 0x0]	
0xA2	RECENT_CH1_LSB	RECENT_CH1_LSB Register (Address = 0xA2) [reset = 0x0]	
0xA3	RECENT_CH1_MSB	RECENT_CH1_MSB Register (Address = 0xA3) [reset = 0x0]	
0xA4	RECENT_CH2_LSB	RECENT_CH2_LSB Register (Address = 0xA4) [reset = 0x0]	

Table 10. ADS7128 Registers (continued)

Address	Acronym	Register Name	Section
0xA5	RECENT_CH2_MSB	RECENT_CH2_MSB Register (Address = 0xA5) [reset = 0x0]	
0xA6	RECENT_CH3_LSB	RECENT_CH3_LSB Register (Address = 0xA6) [reset = 0x0]	
0xA7	RECENT_CH3_MSB	RECENT_CH3_MSB Register (Address = 0xA7) [reset = 0x0]	
0xA8	RECENT_CH4_LSB	RECENT_CH4_LSB Register (Address = 0xA8) [reset = 0x0]	
0xA9	RECENT_CH4_MSB	RECENT_CH4_MSB Register (Address = 0xA9) [reset = 0x0]	
0xAA	RECENT_CH5_LSB	RECENT_CH5_LSB Register (Address = 0xAA) [reset = 0x0]	
0xAB	RECENT_CH5_MSB	RECENT_CH5_MSB Register (Address = 0xAB) [reset = 0x0]	
0xAC	RECENT_CH6_LSB	RECENT_CH6_LSB Register (Address = 0xAC) [reset = 0x0]	
0xAD	RECENT_CH6_MSB	RECENT_CH6_MSB Register (Address = 0xAD) [reset = 0x0]	
0xAE	RECENT_CH7_LSB	RECENT_CH7_LSB Register (Address = 0xAE) [reset = 0x0]	
0xAF	RECENT_CH7_MSB	RECENT_CH7_MSB Register (Address = 0xAF) [reset = 0x0]	
0xC0	RMS_CFG	RMS_CFG Register (Address = 0xC0) [reset = 0x0]	
0xC1	RMS_LSB	RMS_LSB Register (Address = 0xC1) [reset = 0x0]	
0xC2	RMS_MSB	RMS_MSB Register (Address = 0xC2) [reset = 0x0]	
0xC3	GPO0_TRIG_EVENT_SEL	GPO0_TRIG_EVENT_SEL Register (Address = 0xC3) [reset = 0x2]	
0xC5	GPO1_TRIG_EVENT_SEL	GPO1_TRIG_EVENT_SEL Register (Address = 0xC5) [reset = 0x2]	
0xC7	GPO2_TRIG_EVENT_SEL	GPO2_TRIG_EVENT_SEL Register (Address = 0xC7) [reset = 0x2]	
0xC9	GPO3_TRIG_EVENT_SEL	GPO3_TRIG_EVENT_SEL Register (Address = 0xC9) [reset = 0x2]	
0xCB	GPO4_TRIG_EVENT_SEL	GPO4_TRIG_EVENT_SEL Register (Address = 0xCB) [reset = 0x2]	
0xCD	GPO5_TRIG_EVENT_SEL	GPO5_TRIG_EVENT_SEL Register (Address = 0xCD) [reset = 0x2]	
0xCF	GPO6_TRIG_EVENT_SEL	GPO6_TRIG_EVENT_SEL Register (Address = 0xCF) [reset = 0x2]	
0xD1	GPO7_TRIG_EVENT_SEL	GPO7_TRIG_EVENT_SEL Register (Address = 0xD1) [reset = 0x2]	
0xE3	GPO_VALUE_ZCD_CFG_CH0_CH3	GPO_VALUE_ZCD_CFG_CH0_CH3 Register (Address = 0xE3) [reset = 0x0]	
0xE4	GPO_VALUE_ZCD_CFG_CH4_CH7	GPO_VALUE_ZCD_CFG_CH4_CH7 Register (Address = 0xE4) [reset = 0x0]	
0xE7	GPO_ZCD_UPDATE_EN	GPO_ZCD_UPDATE_EN Register (Address = 0xE7) [reset = 0x0]	
0xE9	GPO_TRIGGER_CFG	GPO_TRIGGER_CFG Register (Address = 0xE9) [reset = 0x0]	
0xEB	GPO_VALUE_TRIG	GPO_VALUE_TRIG Register (Address = 0xEB) [reset = 0x0]	

Complex bit access types are encoded to fit into small table cells. [Table 11](#) shows the codes that are used for access types in this section.

Table 11. ADS7128 Access Type Codes

Access Type	Code	Description
Read Type		
R	R	Read
Write Type		
W	W	Write
Reset or Default Value		
-n		Value after reset or the default value
Register Array Variables		

Table 11. ADS7128 Access Type Codes (continued)

Access Type	Code	Description
i,j,k,l,m,n		When these variables are used in a register name, an offset, or an address, they refer to the value of a register array where the register is part of a group of repeating registers. The register groups form a hierarchical structure and the array is represented with a formula.
y		When this variable is used in a register name, an offset, or an address it refers to the value of a register array.

8.6.1 SYSTEM_STATUS Register (Address = 0x0) [reset = 0x81]

SYSTEM_STATUS is shown in [Figure 38](#) and described in [Table 12](#).

Return to the [Summary Table](#).

Figure 38. SYSTEM_STATUS Register

7	6	5	4	3	2	1	0
RSVD	SEQ_STATUS	I ² C_SPEED	RMS_DONE	OSR_DONE	CRC_ERR_FUSE	CRC_ERR_IN	BOR
R-1b	R-0b	R-0b	R/W-0b	R/W-0b	R-0b	R/W-0b	R/W-1b

Table 12. SYSTEM_STATUS Register Field Descriptions

Bit	Field	Type	Reset	Description
7	RSVD	R	1b	Reads return 1b.
6	SEQ_STATUS	R	0b	Status of the channel sequencer. 0b = Sequence stopped 1b = Sequence in progress
5	I ² C_SPEED	R	0b	I ² C high-speed status. 0b = I ² C bus is not in high speed mode. 1b = I ² C bus is in high speed mode.
4	RMS_DONE	R/W	0b	RMS computation status. Clear this bit by writing 1b to this bit. 0b = RMS operation in progress or not started; RMS result not ready. 1b = RMS computation complete; RMS result ready.
3	OSR_DONE	R/W	0b	Averaging status. Clear this bit by writing 1b to this bit. 0b = Averaging in progress or not started; average result is not ready. 1b = Averaging complete; average result is ready.
2	CRC_ERR_FUSE	R	0b	Device power-up configuration CRC check status. To re-evaluate this bit, software reset the device or power cycle AVDD. 0b = No problems detected in power-up configuration. 1b = Device configuration not loaded correctly.
1	CRC_ERR_IN	R/W	0b	Status of CRC check on incoming data. Write 1b to clear this error flag. 0b = No CRC error. 1b = CRC error detected. All register writes, except to addresses 0x00 and 0x01, are blocked.
0	BOR	R/W	1b	Brown out reset indicator. This bit is set if brown out condition occurs or device is power cycled. Write 1b to this bit to clear the flag. 0b = No brown out since last time this bit was cleared. 1b = Brown out condition detected or device power cycled.

8.6.2 GENERAL_CFG Register (Address = 0x1) [reset = 0x0]

GENERAL_CFG is shown in [Figure 39](#) and described in [Table 13](#).

Return to the [Summary Table](#).

Figure 39. GENERAL_CFG Register

7	6	5	4	3	2	1	0
RMS_EN	CRC_EN	STATS_EN	DWC_EN	CNVST	CH_RST	CAL	RST
R/W-0b	R/W-0b	R/W-0b	R/W-0b	W-0b	R/W-0b	R/W-0b	W-0b

Table 13. GENERAL_CFG Register Field Descriptions

Bit	Field	Type	Reset	Description
7	RMS_EN	R/W	0b	Enable or disable the RMS module. 0b = RMS module disabled. 1b = RMS module enabled; writing 1b to this bit clears RMS_RESULT registers and initiates new RMS computation.
6	CRC_EN	R/W	0b	Enable or disable the CRC on device interface. 0b = CRC module disabled. 1b = CRC appended to data output. CRC check is enabled on incoming data.
5	STATS_EN	R/W	0b	Enable or disable the statistics module to update minimum, maximum, and latest output code registers. 0b = Statistics registers are not updated. 1b = Clear statistics registers and continue updating with new conversion results.
4	DWC_EN	R/W	0b	Enable or disable the digital window comparator. 0b = Reset or disable the digital window comparator. 1b = Enable the digital window comparator.
3	CNVST	W	0b	Control start conversion on selected analog input. Readback of this bit returns 0b. 0b = Normal operation; conversions start on the 9th falling edge of I ² C frame. Device stretches SCL until end of conversion or completion of averaging. 1b = Initiate start of conversion. Device does not stretch SCL until end of conversion or completion of averaging.
2	CH_RST	R/W	0b	Force all channels to be analog inputs. 0b = Normal operation. 1b = All channels are configured as analog inputs irrespective of configuration in other registers.
1	CAL	R/W	0b	Calibrate ADC offset. 0b = Normal operation. 1b = ADC offset is calibrated. After calibration is complete, this bit is set to 0b.
0	RST	W	0b	Software reset all registers to default values. 0b = Normal operation. 1b = Device is reset. After reset is complete, this bit is set to 0b and BOR bit is set to 1b.

8.6.3 DATA_CFG Register (Address = 0x2) [reset = 0x0]

DATA_CFG is shown in [Figure 40](#) and described in [Table 14](#).

Return to the [Summary Table](#).

Figure 40. DATA_CFG Register

7	6	5	4	3	2	1	0
FIX_PAT	RESERVED	APPEND_STATUS[1:0]		RESERVED			
R/W-0b	R-0b	R/W-0b		R-0b			

Table 14. DATA_CFG Register Field Descriptions

Bit	Field	Type	Reset	Description
7	FIX_PAT	R/W	0b	Device will output fixed data bits which can be helpful for debugging communication with the device. 0b = Normal operation. 1b = Device will output fixed code 0xA5A repeatedly when reading ADC data.
6	RESERVED	R	0b	Reserved. Reads return 0.
5-4	APPEND_STATUS[1:0]	R/W	0b	Append 4-bit channel ID or status flags to output data. 0b = Channel ID and status flags are not appended to ADC data. 1b = 4-bit channel ID is appended to ADC data. 10b = 4-bit status flags are appended to ADC data. 11b = Reserved.
3-0	RESERVED	R	0b	Reserved. Reads return 0.

8.6.4 OSR_CFG Register (Address = 0x3) [reset = 0x0]

OSR_CFG is shown in [Figure 41](#) and described in [Table 15](#).

Return to the [Summary Table](#).

Figure 41. OSR_CFG Register

7	6	5	4	3	2	1	0
RESERVED					OSR[2:0]		
R-0b					R/W-0b		

Table 15. OSR_CFG Register Field Descriptions

Bit	Field	Type	Reset	Description
7-3	RESERVED	R	0b	Reserved. Reads return 0.
2-0	OSR[2:0]	R/W	0b	Selects the oversampling ratio for ADC conversion result. 0b = No averaging 1b = 2 samples 10b = 4 samples 11b = 8 samples 100b = 16 samples 101b = 32 samples 110b = 64 samples 111b = 128 samples

8.6.5 OPMODE_CFG Register (Address = 0x4) [reset = 0x0]

OPMODE_CFG is shown in [Figure 42](#) and described in [Table 16](#).

Return to the [Summary Table](#).

Figure 42. OPMODE_CFG Register

7	6	5	4	3	2	1	0
CONV_ON_ER R	CONV_MODE[1:0]		OSC_SEL	CLK_DIV[3:0]			
R/W-0b	R/W-0b		R/W-0b	R/W-0b			

Table 16. OPMODE_CFG Register Field Descriptions

Bit	Field	Type	Reset	Description
7	CONV_ON_ERR	R/W	0b	Control continuation of autonomous modes if CRC error is detected on communication interface. 0b = If CRC error is detected, device continues channel sequencing and pin configuration is retained. See the CRC_ERR_IN bit for more details. 1b = If CRC error is detected, device changes all channels to analog inputs and channel sequencing is paused until CRC_ERR_IN bit is set to 0b. After clearing CRC_ERR_IN flag, device resumes channel sequencing and pin configuration is restored.
6-5	CONV_MODE[1:0]	R/W	0b	These bits set the mode of conversion of the ADC. 0b = Manual mode; conversions are initiated by the host. 1b = Autonomous mode; conversions are initiated by the internal state machine.
4	OSC_SEL	R/W	0b	Selects the oscillator for internal timing generation. 0b = High-speed oscillator. 1b = Low-power oscillator.
3-0	CLK_DIV[3:0]	R/W	0b	Sampling speed control in autonomous monitoring mode (CONV_MODE = 01b). See the section on oscillator and timing control for details.

8.6.6 PIN_CFG Register (Address = 0x5) [reset = 0x0]

PIN_CFG is shown in [Figure 43](#) and described in [Table 17](#).

Return to the [Summary Table](#).

Figure 43. PIN_CFG Register

7	6	5	4	3	2	1	0
PIN_CFG[7:0]							
R/W-0b							

Table 17. PIN_CFG Register Field Descriptions

Bit	Field	Type	Reset	Description
7-0	PIN_CFG[7:0]	R/W	0b	Configure device channels AIN/GPIO[7:0] as analog inputs or GPIOs. 0b = Channel is configured as analog input. 1b = Channel is configured as GPIO.

8.6.7 GPIO_CFG Register (Address = 0x7) [reset = 0x0]

GPIO_CFG is shown in [Figure 44](#) and described in [Table 18](#).

Return to the [Summary Table](#).

Figure 44. GPIO_CFG Register

7	6	5	4	3	2	1	0
GPIO_CFG[7:0]							
R/W-0b							

Table 18. GPIO_CFG Register Field Descriptions

Bit	Field	Type	Reset	Description
7-0	GPIO_CFG[7:0]	R/W	0b	Configure GPIO[7:0] as either digital inputs or digital outputs. 0b = GPIO is configured as digital input. 1b = GPIO is configured as digital output.

8.6.8 GPO_DRIVE_CFG Register (Address = 0x9) [reset = 0x0]

GPO_DRIVE_CFG is shown in [Figure 45](#) and described in [Table 19](#).

Return to the [Summary Table](#).

Figure 45. GPO_DRIVE_CFG Register

7	6	5	4	3	2	1	0
GPO_DRIVE_CFG[7:0]							
R/W-0b							

Table 19. GPO_DRIVE_CFG Register Field Descriptions

Bit	Field	Type	Reset	Description
7-0	GPO_DRIVE_CFG[7:0]	R/W	0b	Configure digital outputs GPO[7:0] as either open-drain or push-pull outputs. 0b = Digital output is open-drain; connect external pullup resistor. 1b = Pushpull driver is used for digital output.

8.6.9 GPO_VALUE Register (Address = 0xB) [reset = 0x0]

GPO_VALUE is shown in [Figure 46](#) and described in [Table 20](#).

Return to the [Summary Table](#).

Figure 46. GPO_VALUE Register

7	6	5	4	3	2	1	0
GPO_VALUE[7:0]							
R/W-0b							

Table 20. GPO_VALUE Register Field Descriptions

Bit	Field	Type	Reset	Description
7-0	GPO_VALUE[7:0]	R/W	0b	Logic level to be set on digital outputs GPO[7:0]. 0b = Digital output set to logic 0. 1b = Digital output set to logic 1.

8.6.10 GPI_VALUE Register (Address = 0xD) [reset = 0x0]

GPI_VALUE is shown in [Figure 47](#) and described in [Table 21](#).

Return to the [Summary Table](#).

Figure 47. GPI_VALUE Register

7	6	5	4	3	2	1	0
GPI_VALUE[7:0]							
R-0b							

Table 21. GPI_VALUE Register Field Descriptions

Bit	Field	Type	Reset	Description
7-0	GPI_VALUE[7:0]	R	0b	Readback the logic level on GPIO[7:0]. 0b = GPIO is at logic 0. 1b = GPIO is at logic 1.

8.6.11 ZCD_BLANKING_CFG Register (Address = 0xF) [reset = 0x0]

ZCD_BLANKING_CFG is shown in [Figure 48](#) and described in [Table 22](#).

Return to the [Summary Table](#).

Figure 48. ZCD_BLANKING_CFG Register

7	6	5	4	3	2	1	0
MULT_EN		ZCD_BLANKING[6:0]					
R/W-0b		R/W-0b					

Table 22. ZCD_BLANKING_CFG Register Field Descriptions

Bit	Field	Type	Reset	Description
7	MULT_EN	R/W	0b	Multiplier enable bit for the ZCD_BLANKING field. 0b = Blanking count = ZCD_BLANKING 1b = Blanking count = ZCD_BLANKING x 8
6-0	ZCD_BLANKING[6:0]	R/W	0b	This field defines the number of analog conversions, of the ZCD channel, which must be ignored for generating next ZCD event. The counting starts from ZCD event detection.

8.6.12 SEQUENCE_CFG Register (Address = 0x10) [reset = 0x0]

SEQUENCE_CFG is shown in [Figure 49](#) and described in [Table 23](#).

Return to the [Summary Table](#).

Figure 49. SEQUENCE_CFG Register

7	6	5	4	3	2	1	0
RESERVED			SEQ_START	RESERVED		SEQ_MODE[1:0]	
R-0b			R/W-0b	R-0b		R/W-0b	

Table 23. SEQUENCE_CFG Register Field Descriptions

Bit	Field	Type	Reset	Description
7-5	RESERVED	R	0b	Reserved. Reads return 0.
4	SEQ_START	R/W	0b	Control for start of channel sequence when using auto sequence mode (SEQ_MODE = 01b). 0b = Stop channel sequencing. 1b = Start channel sequencing in ascending order for channels enabled in AUTO_SEQ_CH_SEL register.
3-2	RESERVED	R	0b	Reserved. Reads return 0.
1-0	SEQ_MODE[1:0]	R/W	0b	Selects the mode of scanning of analog input channels. 0b = Manual sequence mode; channel selected by MANUAL_CHID field. 1b = Auto sequence mode; channel selected by internal channel sequencer. 10b = Reserved. 11b = Reserved.

8.6.13 CHANNEL_SEL Register (Address = 0x11) [reset = 0x0]

CHANNEL_SEL is shown in [Figure 50](#) and described in [Table 24](#).

Return to the [Summary Table](#).

Figure 50. CHANNEL_SEL Register

7	6	5	4	3	2	1	0
ZCD_CHID[3:0]				MANUAL_CHID[3:0]			
R/W-0b				R/W-0b			

Table 24. CHANNEL_SEL Register Field Descriptions

Bit	Field	Type	Reset	Description
7-4	ZCD_CHID[3:0]	R/W	0b	Input channel to treat as ZCD input. If the selected channel is configured as an analog input, internally generated ZCD signal is used (setup thresholds accordingly). If the selected channel is a digital input, the digital signal on this channel is directly used as ZCD signal.
3-0	MANUAL_CHID[3:0]	R/W	0b	In manual mode (SEQ_MODE = 00b), this field contains the 4-bit channel ID of the analog input channel for next ADC conversion. For valid ADC data, the selected channel must not be configured as GPIO in PIN_CFG register. 0b = AIN0 1b = AIN1 10b = AIN2 11b = AIN3 100b = AIN4 101b = AIN5 110b = AIN6 111b = AIN7 1000b = Reserved.

8.6.14 AUTO_SEQ_CH_SEL Register (Address = 0x12) [reset = 0x0]

AUTO_SEQ_CH_SEL is shown in [Figure 51](#) and described in [Table 25](#).

Return to the [Summary Table](#).

Figure 51. AUTO_SEQ_CH_SEL Register

7	6	5	4	3	2	1	0
AUTO_SEQ_CH_SEL[7:0]							
R/W-0b							

Table 25. AUTO_SEQ_CH_SEL Register Field Descriptions

Bit	Field	Type	Reset	Description
7-0	AUTO_SEQ_CH_SEL[7:0]	R/W	0b	Select analog input channels AIN[7:0] in for auto sequencing mode. 0b = Analog input channel is not enabled in scanning sequence. 1b = Analog input channel is enabled in scanning sequence.

8.6.15 ALERT_CH_SEL Register (Address = 0x14) [reset = 0x0]

ALERT_CH_SEL is shown in [Figure 52](#) and described in [Table 26](#).

Return to the [Summary Table](#).

Figure 52. ALERT_CH_SEL Register

7	6	5	4	3	2	1	0
ALERT_CH_SEL[7:0]							
R/W-0b							

Table 26. ALERT_CH_SEL Register Field Descriptions

Bit	Field	Type	Reset	Description
7-0	ALERT_CH_SEL[7:0]	R/W	0b	Select channels for which the alert flags can assert the ALERT pin. 0b = Alert flags for this channel do not assert the ALERT pin. 1b = Alert flags for this channel assert the ALERT pin.

8.6.16 ALERT_MAP Register (Address = 0x16) [reset = 0x0]

ALERT_MAP is shown in [Figure 53](#) and described in [Table 27](#).

Return to the [Summary Table](#).

Figure 53. ALERT_MAP Register

7	6	5	4	3	2	1	0
RESERVED						ALERT_RMS	ALERT_CRCIN
R-0b						R/W-0b	R/W-0b

Table 27. ALERT_MAP Register Field Descriptions

Bit	Field	Type	Reset	Description
7-2	RESERVED	R	0b	Reserved. Reads return 0.
1	ALERT_RMS	R/W	0b	Enable or disable the notification on the ALERT pin based on the status of RMS computation (RMS_DONE = 1b). 0b = ALERT pin is not asserted when RMS_DONE = 1b. 1b = ALERT pin is asserted when RMS_DONE = 1b. Clear RMS_DONE flag to deassert the ALERT pin.
0	ALERT_CRCIN	R/W	0b	Enable or disable the notification on the ALERT pin for CRC error on input data (CRCERR_IN = 1b). 0b = ALERT pin is not asserted when CRCERR_IN = 1b. 1b = ALERT pin is asserted when CRCERR_IN = 1b. Clear CRCERR_IN for deasserting the ALERT pin.

8.6.17 ALERT_PIN_CFG Register (Address = 0x17) [reset = 0x0]

ALERT_PIN_CFG is shown in [Figure 54](#) and described in [Table 28](#).

Return to the [Summary Table](#).

Figure 54. ALERT_PIN_CFG Register

7	6	5	4	3	2	1	0
RESERVED					ALERT_DRIVE	ALERT_LOGIC[1:0]	
R-0b					R/W-0b	R/W-0b	

Table 28. ALERT_PIN_CFG Register Field Descriptions

Bit	Field	Type	Reset	Description
7-3	RESERVED	R	0b	Reserved. Reads return 0.
2	ALERT_DRIVE	R/W	0b	Configure output drive of the ALERT pin. 0b = Open-drain output. Connect external pullup resistor. 1b = Push-pull output.
1-0	ALERT_LOGIC[1:0]	R/W	0b	Configure how the ALERT pin is asserted. 0b = Active low. 1b = Active high. 10b = Pulsed low (one logic low pulse one time per alert flag). 11b = Pulsed high (one logic high pulse one time per alert flag).

8.6.18 EVENT_FLAG Register (Address = 0x18) [reset = 0x0]

EVENT_FLAG is shown in [Figure 55](#) and described in [Table 29](#).

Return to the [Summary Table](#).

Figure 55. EVENT_FLAG Register

7	6	5	4	3	2	1	0
EVENT_FLAG[7:0]							
R-0b							

Table 29. EVENT_FLAG Register Field Descriptions

Bit	Field	Type	Reset	Description
7-0	EVENT_FLAG[7:0]	R	0b	Alert flags indicating digital window comparator status for CH[7:0]. Clear individual bits of EVENT_HIGH_FLAG and EVENT_LOW_FLAG registers to clear the corresponding alert flag. 0b = Event condition not detected. 1b = Event condition detected.

8.6.19 EVENT_HIGH_FLAG Register (Address = 0x1A) [reset = 0x0]

EVENT_HIGH_FLAG is shown in [Figure 56](#) and described in [Table 30](#).

Return to the [Summary Table](#).

Figure 56. EVENT_HIGH_FLAG Register

7	6	5	4	3	2	1	0
EVENT_HIGH_FLAG[7:0]							
R/W-0b							

Table 30. EVENT_HIGH_FLAG Register Field Descriptions

Bit	Field	Type	Reset	Description
7-0	EVENT_HIGH_FLAG[7:0]	R/W	0b	Alert flag corresponding to high threshold of analog input or logic 1 on digital input on CH[7:0]. Write 1b to clear this flag. 0b = No alert condition detected. 1b = Either high threshold was exceeded (analog input) or logic 1 was detected (digital input).

8.6.20 EVENT_LOW_FLAG Register (Address = 0x1C) [reset = 0x0]

EVENT_LOW_FLAG is shown in [Figure 57](#) and described in [Table 31](#).

Return to the [Summary Table](#).

Figure 57. EVENT_LOW_FLAG Register

7	6	5	4	3	2	1	0
EVENT_LOW_FLAG[7:0]							
R/W-0b							

Table 31. EVENT_LOW_FLAG Register Field Descriptions

Bit	Field	Type	Reset	Description
7-0	EVENT_LOW_FLAG[7:0]	R/W	0b	Alert flag corresponding to low threshold of analog input or logic 0 on digital input on CH[7:0]. Write 1b to clear this flag. 0b = No Event condition detected. 1b = Either low threshold was exceeded (analog input) or logic 0 was detected (digital input).

8.6.21 EVENT_RGN Register (Address = 0x1E) [reset = 0x0]

EVENT_RGN is shown in [Figure 58](#) and described in [Table 32](#).

Return to the [Summary Table](#).

Figure 58. EVENT_RGN Register

7	6	5	4	3	2	1	0
EVENT_RGN[7:0]							
R/W-0b							

Table 32. EVENT_RGN Register Field Descriptions

Bit	Field	Type	Reset	Description
7-0	EVENT_RGN[7:0]	R/W	0b	Choice of region used in monitoring analog/digital inputs CH[7:0]. 0b = Alert flag is set if: (conversion result < low threshold) or (conversion result > high threshold). For digital inputs, logic 1 sets the alert flag. 1b = Alert flag is set if: (low threshold > conversion result < high threshold). For digital inputs, logic 0 sets the alert flag.

8.6.22 HYSTERESIS_CH0 Register (Address = 0x20) [reset = 0xF0]

 HYSTERESIS_CH0 is shown in [Figure 59](#) and described in [Table 33](#).

 Return to the [Summary Table](#).

Figure 59. HYSTERESIS_CH0 Register

7	6	5	4	3	2	1	0
HIGH_THRESHOLD_CH0_LSB[3:0]				HYSTERESIS_CH0[3:0]			
R/W-1111b				R/W-0b			

Table 33. HYSTERESIS_CH0 Register Field Descriptions

Bit	Field	Type	Reset	Description
7-4	HIGH_THRESHOLD_CH0_LSB[3:0]	R/W	1111b	Lower 4-bits of high threshold for analog input. These bits are compared with bits 3:0 of ADC conversion result.
3-0	HYSTERESIS_CH0[3:0]	R/W	0b	4-bit hysteresis for high and low thresholds. This 4-bit hysteresis is left shifted 3 times and applied on the lower 7-bits of the threshold. Total hysteresis = 7-bits [4-bits, 000b]

8.6.23 HIGH_TH_CH0 Register (Address = 0x21) [reset = 0xFF]

 HIGH_TH_CH0 is shown in [Figure 60](#) and described in [Table 34](#).

 Return to the [Summary Table](#).

Figure 60. HIGH_TH_CH0 Register

7	6	5	4	3	2	1	0
HIGH_THRESHOLD_CH0_MSB[7:0]							
R/W-11111111b							

Table 34. HIGH_TH_CH0 Register Field Descriptions

Bit	Field	Type	Reset	Description
7-0	HIGH_THRESHOLD_CH0_MSB[7:0]	R/W	11111111b	MSB aligned high threshold for analog input. These bits are compared with top 8 bits of ADC conversion result.

8.6.24 EVENT_COUNT_CH0 Register (Address = 0x22) [reset = 0x0]

 EVENT_COUNT_CH0 is shown in [Figure 61](#) and described in [Table 35](#).

 Return to the [Summary Table](#).

Figure 61. EVENT_COUNT_CH0 Register

7	6	5	4	3	2	1	0
LOW_THRESHOLD_CH0_LSB[3:0]				EVENT_COUNT_CH0[3:0]			
R/W-0b				R/W-0b			

Table 35. EVENT_COUNT_CH0 Register Field Descriptions

Bit	Field	Type	Reset	Description
7-4	LOW_THRESHOLD_CH0_LSB[3:0]	R/W	0b	Lower 4-bits of low threshold for analog input. These bits are compared with bits 3:0 of ADC conversion result.
3-0	EVENT_COUNT_CH0[3:0]	R/W	0b	Configuration for checking 'n+1' consecutive samples above threshold before setting event flag.

8.6.25 LOW_TH_CH0 Register (Address = 0x23) [reset = 0x0]

LOW_TH_CH0 is shown in [Figure 62](#) and described in [Table 36](#).

Return to the [Summary Table](#).

Figure 62. LOW_TH_CH0 Register

7	6	5	4	3	2	1	0
LOW_THRESHOLD_CH0_MSB[7:0]							
R/W-0b							

Table 36. LOW_TH_CH0 Register Field Descriptions

Bit	Field	Type	Reset	Description
7-0	LOW_THRESHOLD_CH0_MSB[7:0]	R/W	0b	MSB aligned high threshold for analog input. These bits are compared with top 8 bits of ADC conversion result.

8.6.26 HYSTERESIS_CH1 Register (Address = 0x24) [reset = 0xF0]

HYSTERESIS_CH1 is shown in [Figure 63](#) and described in [Table 37](#).

Return to the [Summary Table](#).

Figure 63. HYSTERESIS_CH1 Register

7	6	5	4	3	2	1	0
HIGH_THRESHOLD_CH1_LSB[3:0]				HYSTERESIS_CH1[3:0]			
R/W-1111b				R/W-0b			

Table 37. HYSTERESIS_CH1 Register Field Descriptions

Bit	Field	Type	Reset	Description
7-4	HIGH_THRESHOLD_CH1_LSB[3:0]	R/W	1111b	Lower 4-bits of high threshold for analog input. These bits are compared with bits 3:0 of ADC conversion result.
3-0	HYSTERESIS_CH1[3:0]	R/W	0b	4-bit hysteresis for high and low thresholds. This 4-bit hysteresis is left shifted 3 times and applied on the lower 7-bits of the threshold. Total hysteresis = 7-bits [4-bits, 000b]

8.6.27 HIGH_TH_CH1 Register (Address = 0x25) [reset = 0xFF]

HIGH_TH_CH1 is shown in [Figure 64](#) and described in [Table 38](#).

Return to the [Summary Table](#).

Figure 64. HIGH_TH_CH1 Register

7	6	5	4	3	2	1	0
HIGH_THRESHOLD_CH1_MSB[7:0]							
R/W-11111111b							

Table 38. HIGH_TH_CH1 Register Field Descriptions

Bit	Field	Type	Reset	Description
7-0	HIGH_THRESHOLD_CH1_MSB[7:0]	R/W	11111111b	MSB aligned high threshold for analog input. These bits are compared with top 8 bits of ADC conversion result.

8.6.28 EVENT_COUNT_CH1 Register (Address = 0x26) [reset = 0x0]

 EVENT_COUNT_CH1 is shown in [Figure 65](#) and described in [Table 39](#).

 Return to the [Summary Table](#).

Figure 65. EVENT_COUNT_CH1 Register

7	6	5	4	3	2	1	0
LOW_THRESHOLD_CH1_LSB[3:0]				EVENT_COUNT_CH1[3:0]			
R/W-0b				R/W-0b			

Table 39. EVENT_COUNT_CH1 Register Field Descriptions

Bit	Field	Type	Reset	Description
7-4	LOW_THRESHOLD_CH1_LSB[3:0]	R/W	0b	Lower 4-bits of low threshold for analog input. These bits are compared with bits 3:0 of ADC conversion result.
3-0	EVENT_COUNT_CH1[3:0]	R/W	0b	Configuration for checking 'n+1' consecutive samples above threshold before setting event flag.

8.6.29 LOW_TH_CH1 Register (Address = 0x27) [reset = 0x0]

 LOW_TH_CH1 is shown in [Figure 66](#) and described in [Table 40](#).

 Return to the [Summary Table](#).

Figure 66. LOW_TH_CH1 Register

7	6	5	4	3	2	1	0
LOW_THRESHOLD_CH1_MSB[7:0]							
R/W-0b							

Table 40. LOW_TH_CH1 Register Field Descriptions

Bit	Field	Type	Reset	Description
7-0	LOW_THRESHOLD_CH1_MSB[7:0]	R/W	0b	MSB aligned high threshold for analog input. These bits are compared with top 8 bits of ADC conversion result.

8.6.30 HYSTERESIS_CH2 Register (Address = 0x28) [reset = 0xF0]

 HYSTERESIS_CH2 is shown in [Figure 67](#) and described in [Table 41](#).

 Return to the [Summary Table](#).

Figure 67. HYSTERESIS_CH2 Register

7	6	5	4	3	2	1	0
HIGH_THRESHOLD_CH2_LSB[3:0]				HYSTERESIS_CH2[3:0]			
R/W-1111b				R/W-0b			

Table 41. HYSTERESIS_CH2 Register Field Descriptions

Bit	Field	Type	Reset	Description
7-4	HIGH_THRESHOLD_CH2_LSB[3:0]	R/W	1111b	Lower 4-bits of high threshold for analog input. These bits are compared with bits 3:0 of ADC conversion result.
3-0	HYSTERESIS_CH2[3:0]	R/W	0b	4-bit hysteresis for high and low thresholds. This 4-bit hysteresis is left shifted 3 times and applied on the lower 7-bits of the threshold. Total hysteresis = 7-bits [4-bits, 000b]

8.6.31 HIGH_TH_CH2 Register (Address = 0x29) [reset = 0xFF]

HIGH_TH_CH2 is shown in [Figure 68](#) and described in [Table 42](#).

Return to the [Summary Table](#).

Figure 68. HIGH_TH_CH2 Register

7	6	5	4	3	2	1	0
HIGH_THRESHOLD_CH2_MSB[7:0]							
R/W-11111111b							

Table 42. HIGH_TH_CH2 Register Field Descriptions

Bit	Field	Type	Reset	Description
7-0	HIGH_THRESHOLD_CH2_MSB[7:0]	R/W	11111111b	MSB aligned high threshold for analog input. These bits are compared with top 8 bits of ADC conversion result.

8.6.32 EVENT_COUNT_CH2 Register (Address = 0x2A) [reset = 0x0]

EVENT_COUNT_CH2 is shown in [Figure 69](#) and described in [Table 43](#).

Return to the [Summary Table](#).

Figure 69. EVENT_COUNT_CH2 Register

7	6	5	4	3	2	1	0
LOW_THRESHOLD_CH2_LSB[3:0]				EVENT_COUNT_CH2[3:0]			
R/W-0b				R/W-0b			

Table 43. EVENT_COUNT_CH2 Register Field Descriptions

Bit	Field	Type	Reset	Description
7-4	LOW_THRESHOLD_CH2_LSB[3:0]	R/W	0b	Lower 4-bits of low threshold for analog input. These bits are compared with bits 3:0 of ADC conversion result.
3-0	EVENT_COUNT_CH2[3:0]	R/W	0b	Configuration for checking 'n+1' consecutive samples above threshold before setting event flag.

8.6.33 LOW_TH_CH2 Register (Address = 0x2B) [reset = 0x0]

LOW_TH_CH2 is shown in [Figure 70](#) and described in [Table 44](#).

Return to the [Summary Table](#).

Figure 70. LOW_TH_CH2 Register

7	6	5	4	3	2	1	0
LOW_THRESHOLD_CH2_MSB[7:0]							
R/W-0b							

Table 44. LOW_TH_CH2 Register Field Descriptions

Bit	Field	Type	Reset	Description
7-0	LOW_THRESHOLD_CH2_MSB[7:0]	R/W	0b	MSB aligned high threshold for analog input. These bits are compared with top 8 bits of ADC conversion result.

8.6.34 HYSTERESIS_CH3 Register (Address = 0x2C) [reset = 0xF0]

HYSTERESIS_CH3 is shown in [Figure 71](#) and described in [Table 45](#).

Return to the [Summary Table](#).

Figure 71. HYSTERESIS_CH3 Register

7	6	5	4	3	2	1	0
HIGH_THRESHOLD_CH3_LSB[3:0]				HYSTERESIS_CH3[3:0]			
R/W-1111b				R/W-0b			

Table 45. HYSTERESIS_CH3 Register Field Descriptions

Bit	Field	Type	Reset	Description
7-4	HIGH_THRESHOLD_CH3_LSB[3:0]	R/W	1111b	Lower 4-bits of high threshold for analog input. These bits are compared with bits 3:0 of ADC conversion result.
3-0	HYSTERESIS_CH3[3:0]	R/W	0b	4-bit hysteresis for high and low thresholds. This 4-bit hysteresis is left shifted 3 times and applied on the lower 7-bits of the threshold. Total hysteresis = 7-bits [4-bits, 000b]

8.6.35 HIGH_TH_CH3 Register (Address = 0x2D) [reset = 0xFF]

HIGH_TH_CH3 is shown in [Figure 72](#) and described in [Table 46](#).

Return to the [Summary Table](#).

Figure 72. HIGH_TH_CH3 Register

7	6	5	4	3	2	1	0
HIGH_THRESHOLD_CH3_MSB[7:0]							
R/W-11111111b							

Table 46. HIGH_TH_CH3 Register Field Descriptions

Bit	Field	Type	Reset	Description
7-0	HIGH_THRESHOLD_CH3_MSB[7:0]	R/W	11111111b	MSB aligned high threshold for analog input. These bits are compared with top 8 bits of ADC conversion result.

8.6.36 EVENT_COUNT_CH3 Register (Address = 0x2E) [reset = 0x0]

EVENT_COUNT_CH3 is shown in [Figure 73](#) and described in [Table 47](#).

Return to the [Summary Table](#).

Figure 73. EVENT_COUNT_CH3 Register

7	6	5	4	3	2	1	0
LOW_THRESHOLD_CH3_LSB[3:0]				EVENT_COUNT_CH3[3:0]			
R/W-0b				R/W-0b			

Table 47. EVENT_COUNT_CH3 Register Field Descriptions

Bit	Field	Type	Reset	Description
7-4	LOW_THRESHOLD_CH3_LSB[3:0]	R/W	0b	Lower 4-bits of low threshold for analog input. These bits are compared with bits 3:0 of ADC conversion result.

Table 47. EVENT_COUNT_CH3 Register Field Descriptions (continued)

Bit	Field	Type	Reset	Description
3-0	EVENT_COUNT_CH3[3:0]	R/W	0b	Configuration for checking 'n+1' consecutive samples above threshold before setting event flag.

8.6.37 LOW_TH_CH3 Register (Address = 0x2F) [reset = 0x0]

LOW_TH_CH3 is shown in [Figure 74](#) and described in [Table 48](#).

Return to the [Summary Table](#).

Figure 74. LOW_TH_CH3 Register

7	6	5	4	3	2	1	0
LOW_THRESHOLD_CH3_MSB[7:0]							
R/W-0b							

Table 48. LOW_TH_CH3 Register Field Descriptions

Bit	Field	Type	Reset	Description
7-0	LOW_THRESHOLD_CH3_MSB[7:0]	R/W	0b	MSB aligned high threshold for analog input. These bits are compared with top 8 bits of ADC conversion result.

8.6.38 HYSTERESIS_CH4 Register (Address = 0x30) [reset = 0xF0]

HYSTERESIS_CH4 is shown in [Figure 75](#) and described in [Table 49](#).

Return to the [Summary Table](#).

Figure 75. HYSTERESIS_CH4 Register

7	6	5	4	3	2	1	0
HIGH_THRESHOLD_CH4_LSB[3:0]				HYSTERESIS_CH4[3:0]			
R/W-1111b				R/W-0b			

Table 49. HYSTERESIS_CH4 Register Field Descriptions

Bit	Field	Type	Reset	Description
7-4	HIGH_THRESHOLD_CH4_LSB[3:0]	R/W	1111b	Lower 4-bits of high threshold for analog input. These bits are compared with bits 3:0 of ADC conversion result.
3-0	HYSTERESIS_CH4[3:0]	R/W	0b	4-bit hysteresis for high and low thresholds. This 4-bit hysteresis is left shifted 3 times and applied on the lower 7-bits of the threshold. Total hysteresis = 7-bits [4-bits, 000b]

8.6.39 HIGH_TH_CH4 Register (Address = 0x31) [reset = 0xFF]

HIGH_TH_CH4 is shown in [Figure 76](#) and described in [Table 50](#).

Return to the [Summary Table](#).

Figure 76. HIGH_TH_CH4 Register

7	6	5	4	3	2	1	0
HIGH_THRESHOLD_CH4_MSB[7:0]							
R/W-11111111b							

Table 50. HIGH_TH_CH4 Register Field Descriptions

Bit	Field	Type	Reset	Description
7-0	HIGH_THRESHOLD_CH4_MSB[7:0]	R/W	11111111b	MSB aligned high threshold for analog input. These bits are compared with top 8 bits of ADC conversion result.

8.6.40 EVENT_COUNT_CH4 Register (Address = 0x32) [reset = 0x0]

 EVENT_COUNT_CH4 is shown in [Figure 77](#) and described in [Table 51](#).

 Return to the [Summary Table](#).

Figure 77. EVENT_COUNT_CH4 Register

7	6	5	4	3	2	1	0
LOW_THRESHOLD_CH4_LSB[3:0]				EVENT_COUNT_CH4[3:0]			
R/W-0b				R/W-0b			

Table 51. EVENT_COUNT_CH4 Register Field Descriptions

Bit	Field	Type	Reset	Description
7-4	LOW_THRESHOLD_CH4_LSB[3:0]	R/W	0b	Lower 4-bits of low threshold for analog input. These bits are compared with bits 3:0 of ADC conversion result.
3-0	EVENT_COUNT_CH4[3:0]	R/W	0b	Configuration for checking 'n+1' consecutive samples above threshold before setting event flag.

8.6.41 LOW_TH_CH4 Register (Address = 0x33) [reset = 0x0]

 LOW_TH_CH4 is shown in [Figure 78](#) and described in [Table 52](#).

 Return to the [Summary Table](#).

Figure 78. LOW_TH_CH4 Register

7	6	5	4	3	2	1	0
LOW_THRESHOLD_CH4_MSB[7:0]							
R/W-0b							

Table 52. LOW_TH_CH4 Register Field Descriptions

Bit	Field	Type	Reset	Description
7-0	LOW_THRESHOLD_CH4_MSB[7:0]	R/W	0b	MSB aligned high threshold for analog input. These bits are compared with top 8 bits of ADC conversion result.

8.6.42 HYSTERESIS_CH5 Register (Address = 0x34) [reset = 0xF0]

 HYSTERESIS_CH5 is shown in [Figure 79](#) and described in [Table 53](#).

 Return to the [Summary Table](#).

Figure 79. HYSTERESIS_CH5 Register

7	6	5	4	3	2	1	0
HIGH_THRESHOLD_CH5_LSB[3:0]				HYSTERESIS_CH5[3:0]			
R/W-1111b				R/W-0b			

Table 53. HYSTERESIS_CH5 Register Field Descriptions

Bit	Field	Type	Reset	Description
7-4	HIGH_THRESHOLD_CH5_LSB[3:0]	R/W	1111b	Lower 4-bits of high threshold for analog input. These bits are compared with bits 3:0 of ADC conversion result.
3-0	HYSTERESIS_CH5[3:0]	R/W	0b	4-bit hysteresis for high and low thresholds. This 4-bit hysteresis is left shifted 3 times and applied on the lower 7-bits of the threshold. Total hysteresis = 7-bits [4-bits, 000b]

8.6.43 HIGH_TH_CH5 Register (Address = 0x35) [reset = 0xFF]

 HIGH_TH_CH5 is shown in [Figure 80](#) and described in [Table 54](#).

 Return to the [Summary Table](#).

Figure 80. HIGH_TH_CH5 Register

7	6	5	4	3	2	1	0
HIGH_THRESHOLD_CH5_MSB[7:0]							
R/W-11111111b							

Table 54. HIGH_TH_CH5 Register Field Descriptions

Bit	Field	Type	Reset	Description
7-0	HIGH_THRESHOLD_CH5_MSB[7:0]	R/W	11111111b	MSB aligned high threshold for analog input. These bits are compared with top 8 bits of ADC conversion result.

8.6.44 EVENT_COUNT_CH5 Register (Address = 0x36) [reset = 0x0]

EVENT_COUNT_CH5 is shown in [Figure 81](#) and described in [Table 55](#).

Return to the [Summary Table](#).

Figure 81. EVENT_COUNT_CH5 Register

7	6	5	4	3	2	1	0
LOW_THRESHOLD_CH5_LSB[3:0]				EVENT_COUNT_CH5[3:0]			
R/W-0b				R/W-0b			

Table 55. EVENT_COUNT_CH5 Register Field Descriptions

Bit	Field	Type	Reset	Description
7-4	LOW_THRESHOLD_CH5_LSB[3:0]	R/W	0b	Lower 4-bits of low threshold for analog input. These bits are compared with bits 3:0 of ADC conversion result.
3-0	EVENT_COUNT_CH5[3:0]	R/W	0b	Configuration for checking 'n+1' consecutive samples above threshold before setting event flag.

8.6.45 LOW_TH_CH5 Register (Address = 0x37) [reset = 0x0]

LOW_TH_CH5 is shown in [Figure 82](#) and described in [Table 56](#).

Return to the [Summary Table](#).

Figure 82. LOW_TH_CH5 Register

7	6	5	4	3	2	1	0
LOW_THRESHOLD_CH5_MSB[7:0]							
R/W-0b							

Table 56. LOW_TH_CH5 Register Field Descriptions

Bit	Field	Type	Reset	Description
7-0	LOW_THRESHOLD_CH5_MSB[7:0]	R/W	0b	MSB aligned high threshold for analog input. These bits are compared with top 8 bits of ADC conversion result.

8.6.46 HYSTERESIS_CH6 Register (Address = 0x38) [reset = 0xF0]

HYSTERESIS_CH6 is shown in [Figure 83](#) and described in [Table 57](#).

Return to the [Summary Table](#).

Figure 83. HYSTERESIS_CH6 Register

7	6	5	4	3	2	1	0
HIGH_THRESHOLD_CH6_LSB[3:0]				HYSTERESIS_CH6[3:0]			
R/W-1111b				R/W-0b			

Table 57. HYSTERESIS_CH6 Register Field Descriptions

Bit	Field	Type	Reset	Description
7-4	HIGH_THRESHOLD_CH6_LSB[3:0]	R/W	1111b	Lower 4-bits of high threshold for analog input. These bits are compared with bits 3:0 of ADC conversion result.
3-0	HYSTERESIS_CH6[3:0]	R/W	0b	4-bit hysteresis for high and low thresholds. This 4-bit hysteresis is left shifted 3 times and applied on the lower 7-bits of the threshold. Total hysteresis = 7-bits [4-bits, 000b]

8.6.47 HIGH_TH_CH6 Register (Address = 0x39) [reset = 0xFF]

HIGH_TH_CH6 is shown in [Figure 84](#) and described in [Table 58](#).

Return to the [Summary Table](#).

Figure 84. HIGH_TH_CH6 Register

7	6	5	4	3	2	1	0
HIGH_THRESHOLD_CH6_MSB[7:0]							
R/W-11111111b							

Table 58. HIGH_TH_CH6 Register Field Descriptions

Bit	Field	Type	Reset	Description
7-0	HIGH_THRESHOLD_CH6_MSB[7:0]	R/W	11111111b	MSB aligned high threshold for analog input. These bits are compared with top 8 bits of ADC conversion result.

8.6.48 EVENT_COUNT_CH6 Register (Address = 0x3A) [reset = 0x0]

EVENT_COUNT_CH6 is shown in [Figure 85](#) and described in [Table 59](#).

Return to the [Summary Table](#).

Figure 85. EVENT_COUNT_CH6 Register

7	6	5	4	3	2	1	0
LOW_THRESHOLD_CH6_LSB[3:0]				EVENT_COUNT_CH6[3:0]			
R/W-0b				R/W-0b			

Table 59. EVENT_COUNT_CH6 Register Field Descriptions

Bit	Field	Type	Reset	Description
7-4	LOW_THRESHOLD_CH6_LSB[3:0]	R/W	0b	Lower 4-bits of low threshold for analog input. These bits are compared with bits 3:0 of ADC conversion result.
3-0	EVENT_COUNT_CH6[3:0]	R/W	0b	Configuration for checking 'n+1' consecutive samples above threshold before setting event flag.

8.6.49 LOW_TH_CH6 Register (Address = 0x3B) [reset = 0x0]

LOW_TH_CH6 is shown in [Figure 86](#) and described in [Table 60](#).

Return to the [Summary Table](#).

Figure 86. LOW_TH_CH6 Register

7	6	5	4	3	2	1	0
LOW_THRESHOLD_CH6_MSB[7:0]							
R/W-0b							

Table 60. LOW_TH_CH6 Register Field Descriptions

Bit	Field	Type	Reset	Description
7-0	LOW_THRESHOLD_CH6_MSB[7:0]	R/W	0b	MSB aligned high threshold for analog input. These bits are compared with top 8 bits of ADC conversion result.

8.6.50 HYSTERESIS_CH7 Register (Address = 0x3C) [reset = 0xF0]

HYSTERESIS_CH7 is shown in [Figure 87](#) and described in [Table 61](#).

Return to the [Summary Table](#).

Figure 87. HYSTERESIS_CH7 Register

7	6	5	4	3	2	1	0
HIGH_THRESHOLD_CH7_LSB[3:0]				HYSTERESIS_CH7[3:0]			
R/W-1111b				R/W-0b			

Table 61. HYSTERESIS_CH7 Register Field Descriptions

Bit	Field	Type	Reset	Description
7-4	HIGH_THRESHOLD_CH7_LSB[3:0]	R/W	1111b	Lower 4-bits of high threshold for analog input. These bits are compared with bits 3:0 of ADC conversion result.
3-0	HYSTERESIS_CH7[3:0]	R/W	0b	4-bit hysteresis for high and low thresholds. This 4-bit hysteresis is left shifted 3 times and applied on the lower 7-bits of the threshold. Total hysteresis = 7-bits [4-bits, 000b]

8.6.51 HIGH_TH_CH7 Register (Address = 0x3D) [reset = 0xFF]

HIGH_TH_CH7 is shown in [Figure 88](#) and described in [Table 62](#).

Return to the [Summary Table](#).

Figure 88. HIGH_TH_CH7 Register

7	6	5	4	3	2	1	0
HIGH_THRESHOLD_CH7_MSB[7:0]							
R/W-11111111b							

Table 62. HIGH_TH_CH7 Register Field Descriptions

Bit	Field	Type	Reset	Description
7-0	HIGH_THRESHOLD_CH7_MSB[7:0]	R/W	11111111b	MSB aligned high threshold for analog input. These bits are compared with top 8 bits of ADC conversion result.

8.6.52 EVENT_COUNT_CH7 Register (Address = 0x3E) [reset = 0x0]

EVENT_COUNT_CH7 is shown in [Figure 89](#) and described in [Table 63](#).

Return to the [Summary Table](#).

Figure 89. EVENT_COUNT_CH7 Register

7	6	5	4	3	2	1	0
LOW_THRESHOLD_CH7_LSB[3:0]				EVENT_COUNT_CH7[3:0]			
R/W-0b				R/W-0b			

Table 63. EVENT_COUNT_CH7 Register Field Descriptions

Bit	Field	Type	Reset	Description
7-4	LOW_THRESHOLD_CH7_LSB[3:0]	R/W	0b	Lower 4-bits of low threshold for analog input. These bits are compared with bits 3:0 of ADC conversion result.

Table 63. EVENT_COUNT_CH7 Register Field Descriptions (continued)

Bit	Field	Type	Reset	Description
3-0	EVENT_COUNT_CH7[3:0]	R/W	0b	Configuration for checking 'n+1' consecutive samples above threshold before setting event flag.

8.6.53 LOW_TH_CH7 Register (Address = 0x3F) [reset = 0x0]

LOW_TH_CH7 is shown in [Figure 90](#) and described in [Table 64](#).

Return to the [Summary Table](#).

Figure 90. LOW_TH_CH7 Register

7	6	5	4	3	2	1	0
LOW_THRESHOLD_CH7_MSB[7:0]							
R/W-0b							

Table 64. LOW_TH_CH7 Register Field Descriptions

Bit	Field	Type	Reset	Description
7-0	LOW_THRESHOLD_CH7_MSB[7:0]	R/W	0b	MSB aligned high threshold for analog input. These bits are compared with top 8 bits of ADC conversion result.

8.6.54 MAX_CH0_LSB Register (Address = 0x60) [reset = 0x0]

MAX_CH0_LSB is shown in [Figure 91](#) and described in [Table 65](#).

Return to the [Summary Table](#).

Figure 91. MAX_CH0_LSB Register

7	6	5	4	3	2	1	0
MAX_VALUE_CH0_LSB[7:0]							
R-0b							

Table 65. MAX_CH0_LSB Register Field Descriptions

Bit	Field	Type	Reset	Description
7-0	MAX_VALUE_CH0_LSB[7:0]	R	0b	Maximum code recorded on the analog input channel from the last time this register was read. Reading the register will reset the value to 0.

8.6.55 MAX_CH0_MSB Register (Address = 0x61) [reset = 0x0]

MAX_CH0_MSB is shown in [Figure 92](#) and described in [Table 66](#).

Return to the [Summary Table](#).

Figure 92. MAX_CH0_MSB Register

7	6	5	4	3	2	1	0
MAX_VALUE_CH0_MSB[7:0]							
R-0b							

Table 66. MAX_CH0_MSB Register Field Descriptions

Bit	Field	Type	Reset	Description
7-0	MAX_VALUE_CH0_MSB[7:0]	R	0b	Maximum code recorded on the analog input channel from the last time this register was read. Reading the register will reset the value to 0.

8.6.56 MAX_CH1_LSB Register (Address = 0x62) [reset = 0x0]

MAX_CH1_LSB is shown in [Figure 93](#) and described in [Table 67](#).

Return to the [Summary Table](#).

Figure 93. MAX_CH1_LSB Register

7	6	5	4	3	2	1	0
MAX_VALUE_CH1_LSB[7:0]							
R-0b							

Table 67. MAX_CH1_LSB Register Field Descriptions

Bit	Field	Type	Reset	Description
7-0	MAX_VALUE_CH1_LSB[7:0]	R	0b	Maximum code recorded on the analog input channel from the last time this register was read. Reading the register will reset the value to 0.

8.6.57 MAX_CH1_MSB Register (Address = 0x63) [reset = 0x0]

MAX_CH1_MSB is shown in [Figure 94](#) and described in [Table 68](#).

Return to the [Summary Table](#).

Figure 94. MAX_CH1_MSB Register

7	6	5	4	3	2	1	0
MAX_VALUE_CH1_MSB[7:0]							
R-0b							

Table 68. MAX_CH1_MSB Register Field Descriptions

Bit	Field	Type	Reset	Description
7-0	MAX_VALUE_CH1_MSB[7:0]	R	0b	Maximum code recorded on the analog input channel from the last time this register was read. Reading the register will reset the value to 0.

8.6.58 MAX_CH2_LSB Register (Address = 0x64) [reset = 0x0]

MAX_CH2_LSB is shown in [Figure 95](#) and described in [Table 69](#).

Return to the [Summary Table](#).

Figure 95. MAX_CH2_LSB Register

7	6	5	4	3	2	1	0
MAX_VALUE_CH2_LSB[7:0]							
R-0b							

Table 69. MAX_CH2_LSB Register Field Descriptions

Bit	Field	Type	Reset	Description
7-0	MAX_VALUE_CH2_LSB[7:0]	R	0b	Maximum code recorded on the analog input channel from the last time this register was read. Reading the register will reset the value to 0.

8.6.59 MAX_CH2_MSB Register (Address = 0x65) [reset = 0x0]

MAX_CH2_MSB is shown in [Figure 96](#) and described in [Table 70](#).

Return to the [Summary Table](#).

Figure 96. MAX_CH2_MSB Register

7	6	5	4	3	2	1	0
MAX_VALUE_CH2_MSB[7:0]							
R-0b							

Table 70. MAX_CH2_MSB Register Field Descriptions

Bit	Field	Type	Reset	Description
7-0	MAX_VALUE_CH2_MSB[7:0]	R	0b	Maximum code recorded on the analog input channel from the last time this register was read. Reading the register will reset the value to 0.

8.6.60 MAX_CH3_LSB Register (Address = 0x66) [reset = 0x0]

MAX_CH3_LSB is shown in [Figure 97](#) and described in [Table 71](#).

Return to the [Summary Table](#).

Figure 97. MAX_CH3_LSB Register

7	6	5	4	3	2	1	0
MAX_VALUE_CH3_LSB[7:0]							
R-0b							

Table 71. MAX_CH3_LSB Register Field Descriptions

Bit	Field	Type	Reset	Description
7-0	MAX_VALUE_CH3_LSB[7:0]	R	0b	Maximum code recorded on the analog input channel from the last time this register was read. Reading the register will reset the value to 0.

8.6.61 MAX_CH3_MSB Register (Address = 0x67) [reset = 0x0]

MAX_CH3_MSB is shown in [Figure 98](#) and described in [Table 72](#).

Return to the [Summary Table](#).

Figure 98. MAX_CH3_MSB Register

7	6	5	4	3	2	1	0
MAX_VALUE_CH3_MSB[7:0]							
R-0b							

Table 72. MAX_CH3_MSB Register Field Descriptions

Bit	Field	Type	Reset	Description
7-0	MAX_VALUE_CH3_MSB[7:0]	R	0b	Maximum code recorded on the analog input channel from the last time this register was read. Reading the register will reset the value to 0.

8.6.62 MAX_CH4_LSB Register (Address = 0x68) [reset = 0x0]

MAX_CH4_LSB is shown in [Figure 99](#) and described in [Table 73](#).

Return to the [Summary Table](#).

Figure 99. MAX_CH4_LSB Register

7	6	5	4	3	2	1	0
MAX_VALUE_CH4_LSB[7:0]							
R-0b							

Table 73. MAX_CH4_LSB Register Field Descriptions

Bit	Field	Type	Reset	Description
7-0	MAX_VALUE_CH4_LSB[7:0]	R	0b	Maximum code recorded on the analog input channel from the last time this register was read. Reading the register will reset the value to 0.

8.6.63 MAX_CH4_MSB Register (Address = 0x69) [reset = 0x0]

MAX_CH4_MSB is shown in [Figure 100](#) and described in [Table 74](#).

Return to the [Summary Table](#).

Figure 100. MAX_CH4_MSB Register

7	6	5	4	3	2	1	0
MAX_VALUE_CH4_MSB[7:0]							
R-0b							

Table 74. MAX_CH4_MSB Register Field Descriptions

Bit	Field	Type	Reset	Description
7-0	MAX_VALUE_CH4_MSB[7:0]	R	0b	Maximum code recorded on the analog input channel from the last time this register was read. Reading the register will reset the value to 0.

8.6.64 MAX_CH5_LSB Register (Address = 0x6A) [reset = 0x0]

MAX_CH5_LSB is shown in [Figure 101](#) and described in [Table 75](#).

Return to the [Summary Table](#).

Figure 101. MAX_CH5_LSB Register

7	6	5	4	3	2	1	0
MAX_VALUE_CH5_LSB[7:0]							
R-0b							

Table 75. MAX_CH5_LSB Register Field Descriptions

Bit	Field	Type	Reset	Description
7-0	MAX_VALUE_CH5_LSB[7:0]	R	0b	Maximum code recorded on the analog input channel from the last time this register was read. Reading the register will reset the value to 0.

8.6.65 MAX_CH5_MSB Register (Address = 0x6B) [reset = 0x0]

MAX_CH5_MSB is shown in [Figure 102](#) and described in [Table 76](#).

Return to the [Summary Table](#).

Figure 102. MAX_CH5_MSB Register

7	6	5	4	3	2	1	0
MAX_VALUE_CH5_MSB[7:0]							
R-0b							

Table 76. MAX_CH5_MSB Register Field Descriptions

Bit	Field	Type	Reset	Description
7-0	MAX_VALUE_CH5_MSB[7:0]	R	0b	Maximum code recorded on the analog input channel from the last time this register was read. Reading the register will reset the value to 0.

8.6.66 MAX_CH6_LSB Register (Address = 0x6C) [reset = 0x0]

 MAX_CH6_LSB is shown in [Figure 103](#) and described in [Table 77](#).

 Return to the [Summary Table](#).

Figure 103. MAX_CH6_LSB Register

7	6	5	4	3	2	1	0
MAX_VALUE_CH6_LSB[7:0]							
R-0b							

Table 77. MAX_CH6_LSB Register Field Descriptions

Bit	Field	Type	Reset	Description
7-0	MAX_VALUE_CH6_LSB[7:0]	R	0b	Maximum code recorded on the analog input channel from the last time this register was read. Reading the register will reset the value to 0.

8.6.67 MAX_CH6_MSB Register (Address = 0x6D) [reset = 0x0]

 MAX_CH6_MSB is shown in [Figure 104](#) and described in [Table 78](#).

 Return to the [Summary Table](#).

Figure 104. MAX_CH6_MSB Register

7	6	5	4	3	2	1	0
MAX_VALUE_CH6_MSB[7:0]							
R-0b							

Table 78. MAX_CH6_MSB Register Field Descriptions

Bit	Field	Type	Reset	Description
7-0	MAX_VALUE_CH6_MSB[7:0]	R	0b	Maximum code recorded on the analog input channel from the last time this register was read. Reading the register will reset the value to 0.

8.6.68 MAX_CH7_LSB Register (Address = 0x6E) [reset = 0x0]

 MAX_CH7_LSB is shown in [Figure 105](#) and described in [Table 79](#).

 Return to the [Summary Table](#).

Figure 105. MAX_CH7_LSB Register

7	6	5	4	3	2	1	0
MAX_VALUE_CH7_LSB[7:0]							
R-0b							

Table 79. MAX_CH7_LSB Register Field Descriptions

Bit	Field	Type	Reset	Description
7-0	MAX_VALUE_CH7_LSB[7:0]	R	0b	Maximum code recorded on the analog input channel from the last time this register was read. Reading the register will reset the value to 0.

8.6.69 MAX_CH7_MSB Register (Address = 0x6F) [reset = 0x0]

 MAX_CH7_MSB is shown in [Figure 106](#) and described in [Table 80](#).

 Return to the [Summary Table](#).

Figure 106. MAX_CH7_MSB Register

7	6	5	4	3	2	1	0
MAX_VALUE_CH7_MSB[7:0]							
R-0b							

Table 80. MAX_CH7_MSB Register Field Descriptions

Bit	Field	Type	Reset	Description
7-0	MAX_VALUE_CH7_MSB[7:0]	R	0b	Maximum code recorded on the analog input channel from the last time this register was read. Reading the register will reset the value to 0.

8.6.70 MIN_CH0_LSB Register (Address = 0x80) [reset = 0xFF]

MIN_CH0_LSB is shown in [Figure 107](#) and described in [Table 81](#).

Return to the [Summary Table](#).

Figure 107. MIN_CH0_LSB Register

7	6	5	4	3	2	1	0
MIN_VALUE_CH0_LSB[7:0]							
R-11111111b							

Table 81. MIN_CH0_LSB Register Field Descriptions

Bit	Field	Type	Reset	Description
7-0	MIN_VALUE_CH0_LSB[7:0]	R	11111111b	Minimum code recorded on the analog input channel from the last time this register was read. Reading the register will reset the value to 0xFF.

8.6.71 MIN_CH0_MSB Register (Address = 0x81) [reset = 0xFF]

MIN_CH0_MSB is shown in [Figure 108](#) and described in [Table 82](#).

Return to the [Summary Table](#).

Figure 108. MIN_CH0_MSB Register

7	6	5	4	3	2	1	0
MIN_VALUE_CH0_MSB[7:0]							
R-11111111b							

Table 82. MIN_CH0_MSB Register Field Descriptions

Bit	Field	Type	Reset	Description
7-0	MIN_VALUE_CH0_MSB[7:0]	R	11111111b	Minimum code recorded on the analog input channel from the last time this register was read. Reading the register will reset the value to 0xFF.

8.6.72 MIN_CH1_LSB Register (Address = 0x82) [reset = 0xFF]

MIN_CH1_LSB is shown in [Figure 109](#) and described in [Table 83](#).

Return to the [Summary Table](#).

Figure 109. MIN_CH1_LSB Register

7	6	5	4	3	2	1	0
MIN_VALUE_CH1_LSB[7:0]							
R-11111111b							

Table 83. MIN_CH1_LSB Register Field Descriptions

Bit	Field	Type	Reset	Description
7-0	MIN_VALUE_CH1_LSB[7:0]	R	11111111b	Minimum code recorded on the analog input channel from the last time this register was read. Reading the register will reset the value to 0xFF.

8.6.73 MIN_CH1_MSB Register (Address = 0x83) [reset = 0xFF]

 MIN_CH1_MSB is shown in [Figure 110](#) and described in [Table 84](#).

 Return to the [Summary Table](#).

Figure 110. MIN_CH1_MSB Register

7	6	5	4	3	2	1	0
MIN_VALUE_CH1_MSB[7:0]							
R-11111111b							

Table 84. MIN_CH1_MSB Register Field Descriptions

Bit	Field	Type	Reset	Description
7-0	MIN_VALUE_CH1_MSB[7:0]	R	11111111b	Minimum code recorded on the analog input channel from the last time this register was read. Reading the register will reset the value to 0xFF.

8.6.74 MIN_CH2_LSB Register (Address = 0x84) [reset = 0xFF]

 MIN_CH2_LSB is shown in [Figure 111](#) and described in [Table 85](#).

 Return to the [Summary Table](#).

Figure 111. MIN_CH2_LSB Register

7	6	5	4	3	2	1	0
MIN_VALUE_CH2_LSB[7:0]							
R-11111111b							

Table 85. MIN_CH2_LSB Register Field Descriptions

Bit	Field	Type	Reset	Description
7-0	MIN_VALUE_CH2_LSB[7:0]	R	11111111b	Minimum code recorded on the analog input channel from the last time this register was read. Reading the register will reset the value to 0xFF.

8.6.75 MIN_CH2_MSB Register (Address = 0x85) [reset = 0xFF]

 MIN_CH2_MSB is shown in [Figure 112](#) and described in [Table 86](#).

 Return to the [Summary Table](#).

Figure 112. MIN_CH2_MSB Register

7	6	5	4	3	2	1	0
MIN_VALUE_CH2_MSB[7:0]							
R-11111111b							

Table 86. MIN_CH2_MSB Register Field Descriptions

Bit	Field	Type	Reset	Description
7-0	MIN_VALUE_CH2_MSB[7:0]	R	11111111b	Minimum code recorded on the analog input channel from the last time this register was read. Reading the register will reset the value to 0xFF.

8.6.76 MIN_CH3_LSB Register (Address = 0x86) [reset = 0xFF]

MIN_CH3_LSB is shown in [Figure 113](#) and described in [Table 87](#).

Return to the [Summary Table](#).

Figure 113. MIN_CH3_LSB Register

7	6	5	4	3	2	1	0
MIN_VALUE_CH3_LSB[7:0]							
R-11111111b							

Table 87. MIN_CH3_LSB Register Field Descriptions

Bit	Field	Type	Reset	Description
7-0	MIN_VALUE_CH3_LSB[7:0]	R	11111111b	Minimum code recorded on the analog input channel from the last time this register was read. Reading the register will reset the value to 0xFF.

8.6.77 MIN_CH3_MSB Register (Address = 0x87) [reset = 0xFF]

MIN_CH3_MSB is shown in [Figure 114](#) and described in [Table 88](#).

Return to the [Summary Table](#).

Figure 114. MIN_CH3_MSB Register

7	6	5	4	3	2	1	0
MIN_VALUE_CH3_MSB[7:0]							
R-11111111b							

Table 88. MIN_CH3_MSB Register Field Descriptions

Bit	Field	Type	Reset	Description
7-0	MIN_VALUE_CH3_MSB[7:0]	R	11111111b	Minimum code recorded on the analog input channel from the last time this register was read. Reading the register will reset the value to 0xFF.

8.6.78 MIN_CH4_LSB Register (Address = 0x88) [reset = 0xFF]

MIN_CH4_LSB is shown in [Figure 115](#) and described in [Table 89](#).

Return to the [Summary Table](#).

Figure 115. MIN_CH4_LSB Register

7	6	5	4	3	2	1	0
MIN_VALUE_CH4_LSB[7:0]							
R-11111111b							

Table 89. MIN_CH4_LSB Register Field Descriptions

Bit	Field	Type	Reset	Description
7-0	MIN_VALUE_CH4_LSB[7:0]	R	11111111b	Minimum code recorded on the analog input channel from the last time this register was read. Reading the register will reset the value to 0xFF.

8.6.79 MIN_CH4_MSB Register (Address = 0x89) [reset = 0xFF]

MIN_CH4_MSB is shown in [Figure 116](#) and described in [Table 90](#).

Return to the [Summary Table](#).

Figure 116. MIN_CH4_MSB Register

7	6	5	4	3	2	1	0
MIN_VALUE_CH4_MSB[7:0]							
R-11111111b							

Table 90. MIN_CH4_MSB Register Field Descriptions

Bit	Field	Type	Reset	Description
7-0	MIN_VALUE_CH4_MSB[7:0]	R	11111111b	Minimum code recorded on the analog input channel from the last time this register was read. Reading the register will reset the value to 0xFF.

8.6.80 MIN_CH5_LSB Register (Address = 0x8A) [reset = 0xFF]

MIN_CH5_LSB is shown in [Figure 117](#) and described in [Table 91](#).

Return to the [Summary Table](#).

Figure 117. MIN_CH5_LSB Register

7	6	5	4	3	2	1	0
MIN_VALUE_CH5_LSB[7:0]							
R-11111111b							

Table 91. MIN_CH5_LSB Register Field Descriptions

Bit	Field	Type	Reset	Description
7-0	MIN_VALUE_CH5_LSB[7:0]	R	11111111b	Minimum code recorded on the analog input channel from the last time this register was read. Reading the register will reset the value to 0xFF.

8.6.81 MIN_CH5_MSB Register (Address = 0x8B) [reset = 0xFF]

MIN_CH5_MSB is shown in [Figure 118](#) and described in [Table 92](#).

Return to the [Summary Table](#).

Figure 118. MIN_CH5_MSB Register

7	6	5	4	3	2	1	0
MIN_VALUE_CH5_MSB[7:0]							
R-11111111b							

Table 92. MIN_CH5_MSB Register Field Descriptions

Bit	Field	Type	Reset	Description
7-0	MIN_VALUE_CH5_MSB[7:0]	R	11111111b	Minimum code recorded on the analog input channel from the last time this register was read. Reading the register will reset the value to 0xFF.

8.6.82 MIN_CH6_LSB Register (Address = 0x8C) [reset = 0xFF]

MIN_CH6_LSB is shown in [Figure 119](#) and described in [Table 93](#).

Return to the [Summary Table](#).

Figure 119. MIN_CH6_LSB Register

7	6	5	4	3	2	1	0
MIN_VALUE_CH6_LSB[7:0]							
R-11111111b							

Table 93. MIN_CH6_LSB Register Field Descriptions

Bit	Field	Type	Reset	Description
7-0	MIN_VALUE_CH6_LSB[7:0]	R	11111111b	Minimum code recorded on the analog input channel from the last time this register was read. Reading the register will reset the value to 0xFF.

8.6.83 MIN_CH6_MSB Register (Address = 0x8D) [reset = 0xFF]

MIN_CH6_MSB is shown in [Figure 120](#) and described in [Table 94](#).

Return to the [Summary Table](#).

Figure 120. MIN_CH6_MSB Register

7	6	5	4	3	2	1	0
MIN_VALUE_CH6_MSB[7:0]							
R-11111111b							

Table 94. MIN_CH6_MSB Register Field Descriptions

Bit	Field	Type	Reset	Description
7-0	MIN_VALUE_CH6_MSB[7:0]	R	11111111b	Minimum code recorded on the analog input channel from the last time this register was read. Reading the register will reset the value to 0xFF.

8.6.84 MIN_CH7_LSB Register (Address = 0x8E) [reset = 0xFF]

MIN_CH7_LSB is shown in [Figure 121](#) and described in [Table 95](#).

Return to the [Summary Table](#).

Figure 121. MIN_CH7_LSB Register

7	6	5	4	3	2	1	0
MIN_VALUE_CH7_LSB[7:0]							
R-11111111b							

Table 95. MIN_CH7_LSB Register Field Descriptions

Bit	Field	Type	Reset	Description
7-0	MIN_VALUE_CH7_LSB[7:0]	R	11111111b	Minimum code recorded on the analog input channel from the last time this register was read. Reading the register will reset the value to 0xFF.

8.6.85 MIN_CH7_MSB Register (Address = 0x8F) [reset = 0xFF]

MIN_CH7_MSB is shown in [Figure 122](#) and described in [Table 96](#).

Return to the [Summary Table](#).

Figure 122. MIN_CH7_MSB Register

7	6	5	4	3	2	1	0
MIN_VALUE_CH7_MSB[7:0]							
R-11111111b							

Table 96. MIN_CH7_MSB Register Field Descriptions

Bit	Field	Type	Reset	Description
7-0	MIN_VALUE_CH7_MSB[7:0]	R	11111111b	Minimum code recorded on the analog input channel from the last time this register was read. Reading the register will reset the value to 0xFF.

8.6.86 RECENT_CH0_LSB Register (Address = 0xA0) [reset = 0x0]

 RECENT_CH0_LSB is shown in [Figure 123](#) and described in [Table 97](#).

 Return to the [Summary Table](#).

Figure 123. RECENT_CH0_LSB Register

7	6	5	4	3	2	1	0
LAST_VALUE_CH0_LSB[7:0]							
R-0b							

Table 97. RECENT_CH0_LSB Register Field Descriptions

Bit	Field	Type	Reset	Description
7-0	LAST_VALUE_CH0_LSB[7:0]	R	0b	Lower 8 bits of the last conversion result for this analog input channel.

8.6.87 RECENT_CH0_MSB Register (Address = 0xA1) [reset = 0x0]

 RECENT_CH0_MSB is shown in [Figure 124](#) and described in [Table 98](#).

 Return to the [Summary Table](#).

Figure 124. RECENT_CH0_MSB Register

7	6	5	4	3	2	1	0
LAST_VALUE_CH0_MSB[7:0]							
R-0b							

Table 98. RECENT_CH0_MSB Register Field Descriptions

Bit	Field	Type	Reset	Description
7-0	LAST_VALUE_CH0_MSB[7:0]	R	0b	MSB aligned first 8 bits of the last conversion result for this analog input channel.

8.6.88 RECENT_CH1_LSB Register (Address = 0xA2) [reset = 0x0]

 RECENT_CH1_LSB is shown in [Figure 125](#) and described in [Table 99](#).

 Return to the [Summary Table](#).

Figure 125. RECENT_CH1_LSB Register

7	6	5	4	3	2	1	0
LAST_VALUE_CH1_LSB[7:0]							
R-0b							

Table 99. RECENT_CH1_LSB Register Field Descriptions

Bit	Field	Type	Reset	Description
7-0	LAST_VALUE_CH1_LSB[7:0]	R	0b	Lower 8 bits of the last conversion result for this analog input channel.

8.6.89 RECENT_CH1_MSB Register (Address = 0xA3) [reset = 0x0]

 RECENT_CH1_MSB is shown in [Figure 126](#) and described in [Table 100](#).

 Return to the [Summary Table](#).

Figure 126. RECENT_CH1_MSB Register

7	6	5	4	3	2	1	0
LAST_VALUE_CH1_MSB[7:0]							
R-0b							

Table 100. RECENT_CH1_MSB Register Field Descriptions

Bit	Field	Type	Reset	Description
7-0	LAST_VALUE_CH1_MSB [7:0]	R	0b	MSB aligned first 8 bits of the last conversion result for this analog input channel.

8.6.90 RECENT_CH2_LSB Register (Address = 0xA4) [reset = 0x0]

RECENT_CH2_LSB is shown in [Figure 127](#) and described in [Table 101](#).

Return to the [Summary Table](#).

Figure 127. RECENT_CH2_LSB Register

7	6	5	4	3	2	1	0
LAST_VALUE_CH2_LSB[7:0]							
R-0b							

Table 101. RECENT_CH2_LSB Register Field Descriptions

Bit	Field	Type	Reset	Description
7-0	LAST_VALUE_CH2_LSB [7:0]	R	0b	Lower 8 bits of the last conversion result for this analog input channel.

8.6.91 RECENT_CH2_MSB Register (Address = 0xA5) [reset = 0x0]

RECENT_CH2_MSB is shown in [Figure 128](#) and described in [Table 102](#).

Return to the [Summary Table](#).

Figure 128. RECENT_CH2_MSB Register

7	6	5	4	3	2	1	0
LAST_VALUE_CH2_MSB[7:0]							
R-0b							

Table 102. RECENT_CH2_MSB Register Field Descriptions

Bit	Field	Type	Reset	Description
7-0	LAST_VALUE_CH2_MSB [7:0]	R	0b	MSB aligned first 8 bits of the last conversion result for this analog input channel.

8.6.92 RECENT_CH3_LSB Register (Address = 0xA6) [reset = 0x0]

RECENT_CH3_LSB is shown in [Figure 129](#) and described in [Table 103](#).

Return to the [Summary Table](#).

Figure 129. RECENT_CH3_LSB Register

7	6	5	4	3	2	1	0
LAST_VALUE_CH3_LSB[7:0]							
R-0b							

Table 103. RECENT_CH3_LSB Register Field Descriptions

Bit	Field	Type	Reset	Description
7-0	LAST_VALUE_CH3_LSB[7:0]	R	0b	Lower 8 bits of the last conversion result for this analog input channel.

8.6.93 RECENT_CH3_MSB Register (Address = 0xA7) [reset = 0x0]

 RECENT_CH3_MSB is shown in [Figure 130](#) and described in [Table 104](#).

 Return to the [Summary Table](#).

Figure 130. RECENT_CH3_MSB Register

7	6	5	4	3	2	1	0
LAST_VALUE_CH3_MSB[7:0]							
R-0b							

Table 104. RECENT_CH3_MSB Register Field Descriptions

Bit	Field	Type	Reset	Description
7-0	LAST_VALUE_CH3_MSB[7:0]	R	0b	MSB aligned first 8 bits of the last conversion result for this analog input channel.

8.6.94 RECENT_CH4_LSB Register (Address = 0xA8) [reset = 0x0]

 RECENT_CH4_LSB is shown in [Figure 131](#) and described in [Table 105](#).

 Return to the [Summary Table](#).

Figure 131. RECENT_CH4_LSB Register

7	6	5	4	3	2	1	0
LAST_VALUE_CH4_LSB[7:0]							
R-0b							

Table 105. RECENT_CH4_LSB Register Field Descriptions

Bit	Field	Type	Reset	Description
7-0	LAST_VALUE_CH4_LSB[7:0]	R	0b	Lower 8 bits of the last conversion result for this analog input channel.

8.6.95 RECENT_CH4_MSB Register (Address = 0xA9) [reset = 0x0]

 RECENT_CH4_MSB is shown in [Figure 132](#) and described in [Table 106](#).

 Return to the [Summary Table](#).

Figure 132. RECENT_CH4_MSB Register

7	6	5	4	3	2	1	0
LAST_VALUE_CH4_MSB[7:0]							
R-0b							

Table 106. RECENT_CH4_MSB Register Field Descriptions

Bit	Field	Type	Reset	Description
7-0	LAST_VALUE_CH4_MSB[7:0]	R	0b	MSB aligned first 8 bits of the last conversion result for this analog input channel.

8.6.96 RECENT_CH5_LSB Register (Address = 0xAA) [reset = 0x0]

 RECENT_CH5_LSB is shown in [Figure 133](#) and described in [Table 107](#).

 Return to the [Summary Table](#).

Figure 133. RECENT_CH5_LSB Register

7	6	5	4	3	2	1	0
LAST_VALUE_CH5_LSB[7:0]							
R-0b							

Table 107. RECENT_CH5_LSB Register Field Descriptions

Bit	Field	Type	Reset	Description
7-0	LAST_VALUE_CH5_LSB[7:0]	R	0b	Lower 8 bits of the last conversion result for this analog input channel.

8.6.97 RECENT_CH5_MSB Register (Address = 0xAB) [reset = 0x0]

 RECENT_CH5_MSB is shown in [Figure 134](#) and described in [Table 108](#).

 Return to the [Summary Table](#).

Figure 134. RECENT_CH5_MSB Register

7	6	5	4	3	2	1	0
LAST_VALUE_CH5_MSB[7:0]							
R-0b							

Table 108. RECENT_CH5_MSB Register Field Descriptions

Bit	Field	Type	Reset	Description
7-0	LAST_VALUE_CH5_MSB[7:0]	R	0b	MSB aligned first 8 bits of the last conversion result for this analog input channel.

8.6.98 RECENT_CH6_LSB Register (Address = 0xAC) [reset = 0x0]

 RECENT_CH6_LSB is shown in [Figure 135](#) and described in [Table 109](#).

 Return to the [Summary Table](#).

Figure 135. RECENT_CH6_LSB Register

7	6	5	4	3	2	1	0
LAST_VALUE_CH6_LSB[7:0]							
R-0b							

Table 109. RECENT_CH6_LSB Register Field Descriptions

Bit	Field	Type	Reset	Description
7-0	LAST_VALUE_CH6_LSB[7:0]	R	0b	Lower 8 bits of the last conversion result for this analog input channel.

8.6.99 RECENT_CH6_MSB Register (Address = 0xAD) [reset = 0x0]

 RECENT_CH6_MSB is shown in [Figure 136](#) and described in [Table 110](#).

 Return to the [Summary Table](#).

Figure 136. RECENT_CH6_MSB Register

7	6	5	4	3	2	1	0
LAST_VALUE_CH6_MSB[7:0]							
R-0b							

Table 110. RECENT_CH6_MSB Register Field Descriptions

Bit	Field	Type	Reset	Description
7-0	LAST_VALUE_CH6_MSB [7:0]	R	0b	MSB aligned first 8 bits of the last conversion result for this analog input channel.

8.6.100 RECENT_CH7_LSB Register (Address = 0xAE) [reset = 0x0]

 RECENT_CH7_LSB is shown in [Figure 137](#) and described in [Table 111](#).

 Return to the [Summary Table](#).

Figure 137. RECENT_CH7_LSB Register

7	6	5	4	3	2	1	0
LAST_VALUE_CH7_LSB[7:0]							
R-0b							

Table 111. RECENT_CH7_LSB Register Field Descriptions

Bit	Field	Type	Reset	Description
7-0	LAST_VALUE_CH7_LSB [7:0]	R	0b	Lower 8 bits of the last conversion result for this analog input channel.

8.6.101 RECENT_CH7_MSB Register (Address = 0xAF) [reset = 0x0]

 RECENT_CH7_MSB is shown in [Figure 138](#) and described in [Table 112](#).

 Return to the [Summary Table](#).

Figure 138. RECENT_CH7_MSB Register

7	6	5	4	3	2	1	0
LAST_VALUE_CH7_MSB[7:0]							
R-0b							

Table 112. RECENT_CH7_MSB Register Field Descriptions

Bit	Field	Type	Reset	Description
7-0	LAST_VALUE_CH7_MSB [7:0]	R	0b	MSB aligned first 8 bits of the last conversion result for this analog input channel.

8.6.102 RMS_CFG Register (Address = 0xC0) [reset = 0x0]

 RMS_CFG is shown in [Figure 139](#) and described in [Table 113](#).

 Return to the [Summary Table](#).

Figure 139. RMS_CFG Register

7	6	5	4	3	2	1	0
RMS_CHID[3:0]			RESERVED	RMS_DC_SUB	RMS_SAMPLES[1:0]		
R/W-0b			R-0b	R/W-0b	R/W-0b		

Table 113. RMS_CFG Register Field Descriptions

Bit	Field	Type	Reset	Description
7-4	RMS_CHID[3:0]	R/W	0b	Select analog input channel for RMS computation.
3	RESERVED	R	0b	Reserved. Reads return 0b.
2	RMS_DC_SUB	R/W	0b	Subtract DC component from the RMS result. 0b = Do not subtract DC component. 1b = Subtract DC component.
1-0	RMS_SAMPLES[1:0]	R/W	0b	Number of samples for computing RMS result. Additional 40 samples are required for completing RMS computation. 0b = 1024 1b = 4096 10b = 16384 11b = 65536

8.6.103 RMS_LSB Register (Address = 0xC1) [reset = 0x0]

RMS_LSB is shown in [Figure 140](#) and described in [Table 114](#).

Return to the [Summary Table](#).

Figure 140. RMS_LSB Register

7	6	5	4	3	2	1	0
RMS_RESULT_LSB[7:0]							
R-0b							

Table 114. RMS_LSB Register Field Descriptions

Bit	Field	Type	Reset	Description
7-0	RMS_RESULT_LSB[7:0]	R	0b	Lower 8-bits of RMS computation result.

8.6.104 RMS_MSB Register (Address = 0xC2) [reset = 0x0]

RMS_MSB is shown in [Figure 141](#) and described in [Table 115](#).

Return to the [Summary Table](#).

Figure 141. RMS_MSB Register

7	6	5	4	3	2	1	0
RMS_RESULT_MSB[7:0]							
R-0b							

Table 115. RMS_MSB Register Field Descriptions

Bit	Field	Type	Reset	Description
7-0	RMS_RESULT_MSB[7:0]	R	0b	Upper 8-bits of RMS result.

8.6.105 GPO0_TRIG_EVENT_SEL Register (Address = 0xC3) [reset = 0x2]

GPO0_TRIG_EVENT_SEL is shown in [Figure 142](#) and described in [Table 116](#).

Return to the [Summary Table](#).

Figure 142. GPO0_TRIG_EVENT_SEL Register

7	6	5	4	3	2	1	0
GPO0_TRIG_EVENT_SEL[7:0]							
R/W-10b							

Table 116. GPO0_TRIG_EVENT_SEL Register Field Descriptions

Bit	Field	Type	Reset	Description
7-0	GPO0_TRIG_EVENT_SEL[7:0]	R/W	10b	Select the inputs AIN/GPIO[7:0], analog or digital, which can trigger an event based update on GPO0. 0b = Alert flags for the AIN/GPIO corresponding to this bit do not trigger GPO0 output. 1b = Alert flags for the AIN/GPIO corresponding to this bit do trigger GPO0 output.

8.6.106 GPO1_TRIG_EVENT_SEL Register (Address = 0xC5) [reset = 0x2]

GPO1_TRIG_EVENT_SEL is shown in [Figure 143](#) and described in [Table 117](#).

Return to the [Summary Table](#).

Figure 143. GPO1_TRIG_EVENT_SEL Register

7	6	5	4	3	2	1	0
GPO1_TRIG_EVENT_SEL[7:0]							
R/W-10b							

Table 117. GPO1_TRIG_EVENT_SEL Register Field Descriptions

Bit	Field	Type	Reset	Description
7-0	GPO1_TRIG_EVENT_SEL[7:0]	R/W	10b	Select the inputs AIN/GPIO[7:0], analog or digital, which can trigger an event based update on GPO1. 0b = Alert flags for the AIN/GPIO corresponding to this bit do not trigger GPO1 output. 1b = Alert flags for the AIN/GPIO corresponding to this bit do trigger GPO1 output.

8.6.107 GPO2_TRIG_EVENT_SEL Register (Address = 0xC7) [reset = 0x2]

GPO2_TRIG_EVENT_SEL is shown in [Figure 144](#) and described in [Table 118](#).

Return to the [Summary Table](#).

Figure 144. GPO2_TRIG_EVENT_SEL Register

7	6	5	4	3	2	1	0
GPO2_TRIG_EVENT_SEL[7:0]							
R/W-10b							

Table 118. GPO2_TRIG_EVENT_SEL Register Field Descriptions

Bit	Field	Type	Reset	Description
7-0	GPO2_TRIG_EVENT_SEL[7:0]	R/W	10b	Select the inputs AIN/GPIO[7:0], analog or digital, which can trigger an event based update on GPO2. 0b = Alert flags for the AIN/GPIO corresponding to this bit do not trigger GPO2 output. 1b = Alert flags for the AIN/GPIO corresponding to this bit do trigger GPO2 output.

8.6.108 GPO3_TRIG_EVENT_SEL Register (Address = 0xC9) [reset = 0x2]

GPO3_TRIG_EVENT_SEL is shown in [Figure 145](#) and described in [Table 119](#).

Return to the [Summary Table](#).

Figure 145. GPO3_TRIG_EVENT_SEL Register

7	6	5	4	3	2	1	0
GPO3_TRIG_EVENT_SEL[7:0]							
R/W-10b							

Table 119. GPO3_TRIG_EVENT_SEL Register Field Descriptions

Bit	Field	Type	Reset	Description
7-0	GPO3_TRIG_EVENT_SEL[7:0]	R/W	10b	Select the inputs AIN/GPIO[7:0], analog or digital, which can trigger an event based update on GPO3. 0b = Alert flags for the AIN/GPIO corresponding to this bit do not trigger GPO3 output. 1b = Alert flags for the AIN/GPIO corresponding to this bit do trigger GPO3 output.

8.6.109 GPO4_TRIG_EVENT_SEL Register (Address = 0xCB) [reset = 0x2]

GPO4_TRIG_EVENT_SEL is shown in [Figure 146](#) and described in [Table 120](#).

Return to the [Summary Table](#).

Figure 146. GPO4_TRIG_EVENT_SEL Register

7	6	5	4	3	2	1	0
GPO4_TRIG_EVENT_SEL[7:0]							
R/W-10b							

Table 120. GPO4_TRIG_EVENT_SEL Register Field Descriptions

Bit	Field	Type	Reset	Description
7-0	GPO4_TRIG_EVENT_SEL[7:0]	R/W	10b	Select the inputs AIN/GPIO[7:0], analog or digital, which can trigger an event based update on GPO4. 0b = Alert flags for the AIN/GPIO corresponding to this bit do not trigger GPO4 output. 1b = Alert flags for the AIN/GPIO corresponding to this bit do trigger GPO4 output.

8.6.110 GPO5_TRIG_EVENT_SEL Register (Address = 0xCD) [reset = 0x2]

GPO5_TRIG_EVENT_SEL is shown in [Figure 147](#) and described in [Table 121](#).

Return to the [Summary Table](#).

Figure 147. GPO5_TRIG_EVENT_SEL Register

7	6	5	4	3	2	1	0
GPO0_TRIG_EVENT_SEL[7:0]							
R/W-10b							

Table 121. GPO5_TRIG_EVENT_SEL Register Field Descriptions

Bit	Field	Type	Reset	Description
7-0	GPO0_TRIG_EVENT_SEL[7:0]	R/W	10b	Select the inputs AIN/GPIO[7:0], analog or digital, which can trigger an event based update on GPO5. 0b = Alert flags for the AIN/GPIO corresponding to this bit do not trigger GPO5 output. 1b = Alert flags for the AIN/GPIO corresponding to this bit do trigger GPO5 output.

8.6.111 GPO6_TRIG_EVENT_SEL Register (Address = 0xCF) [reset = 0x2]

 GPO6_TRIG_EVENT_SEL is shown in [Figure 148](#) and described in [Table 122](#).

 Return to the [Summary Table](#).

Figure 148. GPO6_TRIG_EVENT_SEL Register

7	6	5	4	3	2	1	0
GPO6_TRIG_EVENT_SEL[7:0]							
R/W-10b							

Table 122. GPO6_TRIG_EVENT_SEL Register Field Descriptions

Bit	Field	Type	Reset	Description
7-0	GPO6_TRIG_EVENT_SEL[7:0]	R/W	10b	Select the inputs AIN/GPIO[7:0], analog or digital, which can trigger an event based update on GPO6. 0b = Alert flags for the AIN/GPIO corresponding to this bit do not trigger GPO6 output. 1b = Alert flags for the AIN/GPIO corresponding to this bit do trigger GPO6 output.

8.6.112 GPO7_TRIG_EVENT_SEL Register (Address = 0xD1) [reset = 0x2]

 GPO7_TRIG_EVENT_SEL is shown in [Figure 149](#) and described in [Table 123](#).

 Return to the [Summary Table](#).

Figure 149. GPO7_TRIG_EVENT_SEL Register

7	6	5	4	3	2	1	0
GPO7_TRIG_EVENT_SEL[7:0]							
R/W-10b							

Table 123. GPO7_TRIG_EVENT_SEL Register Field Descriptions

Bit	Field	Type	Reset	Description
7-0	GPO7_TRIG_EVENT_SEL[7:0]	R/W	10b	Select the inputs AIN/GPIO[7:0], analog or digital, which can trigger an event based update on GPO7. 0b = Alert flags for the AIN/GPIO corresponding to this bit do not trigger GPO7 output. 1b = Alert flags for the AIN/GPIO corresponding to this bit do trigger GPO7 output.

8.6.113 GPO_VALUE_ZCD_CFG_CH0_CH3 Register (Address = 0xE3) [reset = 0x0]

 GPO_VALUE_ZCD_CFG_CH0_CH3 is shown in [Figure 150](#) and described in [Table 124](#).

 Return to the [Summary Table](#).

Figure 150. GPO_VALUE_ZCD_CFG_CH0_CH3 Register

7	6	5	4	3	2	1	0
GPO_VALUE_ZCD_CFG_CH3[1:0]		GPO_VALUE_ZCD_CFG_CH2[1:0]		GPO_VALUE_ZCD_CFG_CH1[1:0]		GPO_VALUE_ZCD_CFG_CH0[1:0]	
R/W-0b		R/W-0b		R/W-0b		R/W-0b	

Table 124. GPO_VALUE_ZCD_CFG_CH0_CH3 Register Field Descriptions

Bit	Field	Type	Reset	Description
7-6	GPO_VALUE_ZCD_CFG_CH3[1:0]	R/W	0b	Define the GPO value to be launched on ZCD rising and falling edges. 0b = Rising (0) and falling (0) -> logic 0 on both edges 1b = Rising (0) and falling (1) -> \overline{ZCD} 10b = Rising (1) and falling (0) -> ZCD 11b = Rising (1) and falling (1) -> logic 1 on both edges
5-4	GPO_VALUE_ZCD_CFG_CH2[1:0]	R/W	0b	Define the GPO value to be launched on ZCD rising and falling edges. 0b = Rising (0) and falling (0) -> logic 0 on both edges 1b = Rising (0) and falling (1) -> \overline{ZCD} 10b = Rising (1) and falling (0) -> ZCD 11b = Rising (1) and falling (1) -> logic 1 on both edges
3-2	GPO_VALUE_ZCD_CFG_CH1[1:0]	R/W	0b	Define the GPO value to be launched on ZCD rising and falling edges. 0b = Rising (0) and falling (0) -> logic 0 on both edges 1b = Rising (0) and falling (1) -> \overline{ZCD} 10b = Rising (1) and falling (0) -> ZCD 11b = Rising (1) and falling (1) -> logic 1 on both edges
1-0	GPO_VALUE_ZCD_CFG_CH0[1:0]	R/W	0b	Define the GPO value to be launched on ZCD rising and falling edges. 0b = Rising (0) and falling (0) -> logic 0 on both edges 1b = Rising (0) and falling (1) -> \overline{ZCD} 10b = Rising (1) and falling (0) -> ZCD 11b = Rising (1) and falling (1) -> logic 1 on both edges

8.6.114 GPO_VALUE_ZCD_CFG_CH4_CH7 Register (Address = 0xE4) [reset = 0x0]

GPO_VALUE_ZCD_CFG_CH4_CH7 is shown in [Figure 151](#) and described in [Table 125](#).

Return to the [Summary Table](#).

Figure 151. GPO_VALUE_ZCD_CFG_CH4_CH7 Register

7	6	5	4	3	2	1	0
GPO_VALUE_ZCD_CFG_CH7[1:0]	GPO_VALUE_ZCD_CFG_CH6[1:0]	GPO_VALUE_ZCD_CFG_CH5[1:0]	GPO_VALUE_ZCD_CFG_CH4[1:0]	GPO_VALUE_ZCD_CFG_CH3[1:0]	GPO_VALUE_ZCD_CFG_CH2[1:0]	GPO_VALUE_ZCD_CFG_CH1[1:0]	GPO_VALUE_ZCD_CFG_CH0[1:0]
R/W-0b	R/W-0b	R/W-0b	R/W-0b	R/W-0b	R/W-0b	R/W-0b	R/W-0b

Table 125. GPO_VALUE_ZCD_CFG_CH4_CH7 Register Field Descriptions

Bit	Field	Type	Reset	Description
7-6	GPO_VALUE_ZCD_CFG_CH7[1:0]	R/W	0b	Define the GPO value to be launched on ZCD rising and falling edges. 0b = Rising (0) and falling (0) -> logic 0 on both edges 1b = Rising (0) and falling (1) -> \overline{ZCD} 10b = Rising (1) and falling (0) -> ZCD 11b = Rising (1) and falling (1) -> logic 1 on both edges
5-4	GPO_VALUE_ZCD_CFG_CH6[1:0]	R/W	0b	Define the GPO value to be launched on ZCD rising and falling edges. 0b = Rising (0) and falling (0) -> logic 0 on both edges 1b = Rising (0) and falling (1) -> \overline{ZCD} 10b = Rising (1) and falling (0) -> ZCD 11b = Rising (1) and falling (1) -> logic 1 on both edges

Table 125. GPO_VALUE_ZCD_CFG_CH4_CH7 Register Field Descriptions (continued)

Bit	Field	Type	Reset	Description
3-2	GPO_VALUE_ZCD_CFG_CH5[1:0]	R/W	0b	Define the GPO value to be launched on ZCD rising and falling edges. 0b = Rising (0) and falling (0) -> logic 0 on both edges 1b = Rising (0) and falling (1) -> $\overline{\text{ZCD}}$ 10b = Rising (1) and falling (0) -> ZCD 11b = Rising (1) and falling (1) -> logic 1 on both edges
1-0	GPO_VALUE_ZCD_CFG_CH4[1:0]	R/W	0b	Define the GPO value to be launched on ZCD rising and falling edges. 0b = Rising (0) and falling (0) -> logic 0 on both edges 1b = Rising (0) and falling (1) -> $\overline{\text{ZCD}}$ 10b = Rising (1) and falling (0) -> ZCD 11b = Rising (1) and falling (1) -> logic 1 on both edges

8.6.115 GPO_ZCD_UPDATE_EN Register (Address = 0xE7) [reset = 0x0]

 GPO_ZCD_UPDATE_EN is shown in [Figure 152](#) and described in [Table 126](#).

 Return to the [Summary Table](#).

Figure 152. GPO_ZCD_UPDATE_EN Register

7	6	5	4	3	2	1	0
GPO_ZCD_UPDATE_EN[7:0]							
R/W-0b							

Table 126. GPO_ZCD_UPDATE_EN Register Field Descriptions

Bit	Field	Type	Reset	Description
7-0	GPO_ZCD_UPDATE_EN[7:0]	R/W	0b	Update digital outputs GPO[7:0] synchronous to ZCD. 0b = Digital output is not updated synchronous to the ZCD event. 1b = Digital output is updated synchronous to ZCD event. Configure the GPO_VALUE_ON_ZCD_CFG register.

8.6.116 GPO_TRIGGER_CFG Register (Address = 0xE9) [reset = 0x0]

 GPO_TRIGGER_CFG is shown in [Figure 153](#) and described in [Table 127](#).

 Return to the [Summary Table](#).

Figure 153. GPO_TRIGGER_CFG Register

7	6	5	4	3	2	1	0
GPO_TRIGGER_UPDATE_EN[7:0]							
R/W-0b							

Table 127. GPO_TRIGGER_CFG Register Field Descriptions

Bit	Field	Type	Reset	Description
7-0	GPO_TRIGGER_UPDATE_EN[7:0]	R/W	0b	Update digital outputs GPO[7:0] when the corresponding trigger is set. 0b = Digital output is not updated in response to the alert flags. 1b = Digital output is updated when the corresponding alert flags are set. Configure GPOx_TRIG_EVENT_SEL register to select which alert flags can trigger an update on the desired GPO.

8.6.117 GPO_VALUE_TRIG Register (Address = 0xEB) [reset = 0x0]

 GPO_VALUE_TRIG is shown in [Figure 154](#) and described in [Table 128](#).

 Return to the [Summary Table](#).

Figure 154. GPO_VALUE_TRIG Register

7	6	5	4	3	2	1	0
GPO_VALUE_ON_TRIGGER[7:0]							
R/W-0b							

Table 128. GPO_VALUE_TRIG Register Field Descriptions

Bit	Field	Type	Reset	Description
7-0	GPO_VALUE_ON_TRIGGER[7:0]	R/W	0b	Value to be set on digital outputs GPO[7:0] when the corresponding trigger occurs. GPO update on alert flags must be enabled in the corresponding bit in the GPO_TRIGGER_CFG register. 0b = Digital output is set to logic 0. 1b = Digital output is set to logic 1.

9 Application and Implementation

NOTE

Information in the following applications sections is not part of the TI component specification, and TI does not warrant its accuracy or completeness. TI's customers are responsible for determining suitability of components for their purposes. Customers should validate and test their design implementation to confirm system functionality.

9.1 Application Information

The following sections give example circuits and suggestions for using the ADS7128 in various applications.

9.2 Typical Applications

9.2.1 Mixed-Channel Configuration

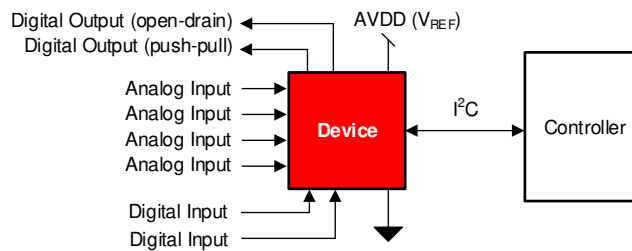

Figure 155. DAQ Circuit: Single-Supply DAQ

9.2.1.1 Design Requirements

The goal of this application is to configure some channels of the ADS7128 as digital inputs, open-drain digital outputs, and push-pull digital outputs.

9.2.1.2 Detailed Design Procedure

The ADS7128 can support GPIO functionality at each input pin. Any analog input pin can be independently configured as a digital input, a digital open-drain output, or a digital push-pull output through the PIN_CFG and GPIO_CFG registers; see [Table 4](#).

9.2.1.2.1 Digital Input

The digital input functionality can be used to monitor a signal within the system. [Figure 156](#) illustrates that the state of the digital input can be read from the GPI_VALUE register.

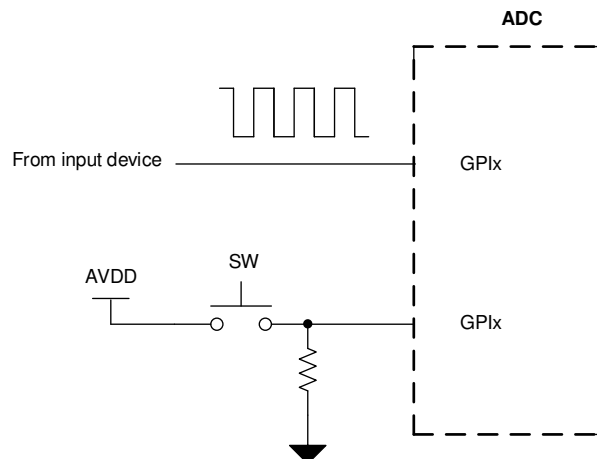

Figure 156. Digital Input

Typical Applications (continued)

9.2.1.2.2 Digital Open-Drain Output

The channels of the ADS7128 can be configured as digital open-drain outputs supporting an output voltage up to 5.5 V. An open-drain output, as shown in Figure 157, consists of an internal FET (Q) connected to ground. The output is idle when not driven by the device, which means Q is off and the pull-up resistor, R_{PULL_UP} , connects the GPOx node to the desired output voltage. The output voltage can range anywhere up to 5.5 V, depending on the external voltage that the GPIOx is pulled up to. When the device is driving the output, Q turns on, thus connecting the pull-up resistor to ground and bringing the node voltage at GPOx low.

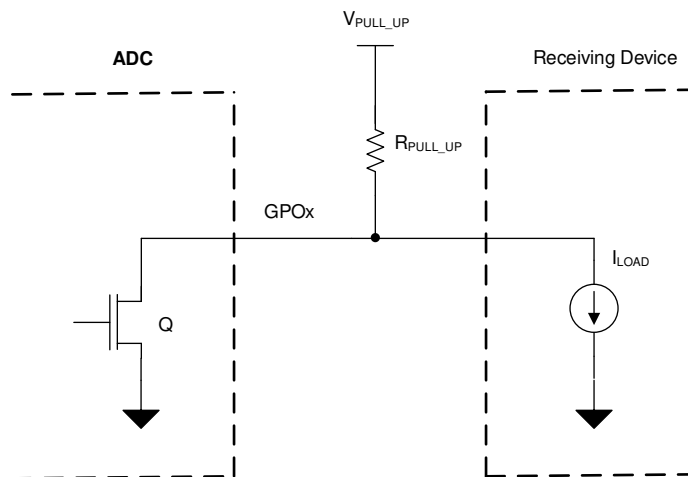

Figure 157. Digital Open-Drain Output

The minimum value of the pullup resistor, as calculated in Equation 6, is given by the ratio of V_{PULL_UP} and the maximum current supported by the device digital output (5 mA).

$$R_{MIN} = (V_{PULL_UP} / 5 \text{ mA}) \tag{6}$$

The maximum value of the pullup resistor, as calculated in Equation 7, depends on the minimum input current requirement, I_{LOAD} , of the receiving device driven by this GPIO.

$$R_{MAX} = (V_{PULL_UP} / I_{LOAD}) \tag{7}$$

Select R_{PULL_UP} such that $R_{MIN} < R_{PULL_UP} < R_{MAX}$.

9.2.1.3 Application Curve

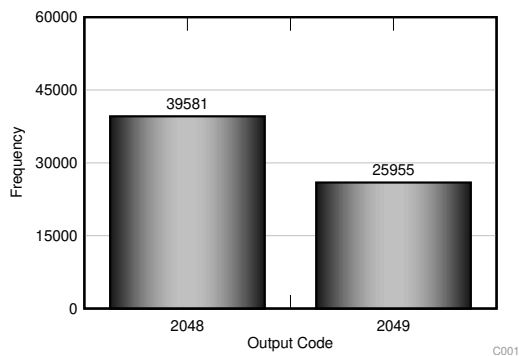

Standard deviation = 0.49 LSB

Figure 158. DC Input Histogram

Typical Applications (continued)

9.2.2 Digital Push-Pull Output

The channels of the ADS7128 can be configured as digital push-pull outputs supporting an output voltage up to AVDD. As shown in Figure 159, a push-pull output consists of two mirrored opposite bipolar transistors, Q1 and Q2. The device can both source and sink current because only one transistor is on at a time (either Q2 is on and pulls the output low, or Q1 is on and sets the output high). A push-pull configuration always drives the line opposed to an open-drain output where the line is left floating.

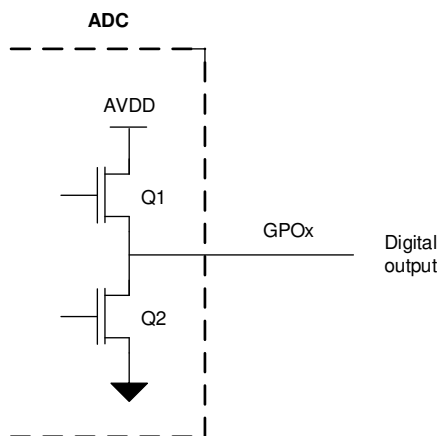

Figure 159. Digital Push-Pull Output

10 Power Supply Recommendations

10.1 AVDD and DVDD Supply Recommendations

The ADS7128 has two separate power supplies: AVDD and DVDD. The device operates on AVDD; DVDD is used for the interface circuits. For supplies greater than 2.35 V, AVDD and DVDD can be shorted externally if single-supply operation is desired. The AVDD supply also defines the full-scale input range of the device. Decouple the AVDD and DVDD pins individually, as shown in [Figure 160](#), with 1- μ F ceramic decoupling capacitors. The minimum capacitor value required for AVDD and DVDD is 200 nF and 20 nF, respectively. If both supplies are powered from the same source, a minimum capacitor value of 220 nF is required for decoupling.

Connect a 1- μ F decoupling capacitor between the DECAP and GND pins for the internal power supply.

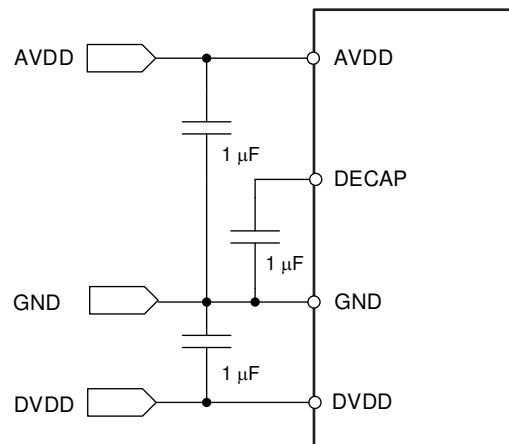

Figure 160. Power-Supply Decoupling

11 Layout

11.1 Layout Guidelines

Figure 161 shows a board layout example for the ADS7128. Avoid crossing digital lines with the analog signal path and keep the analog input signals and the AVDD supply away from noise sources.

Use 1- μ F ceramic bypass capacitors in close proximity to the analog (AVDD) and digital (DVDD) power-supply pins. Avoid placing vias between the AVDD and DVDD pins and the bypass capacitors. Connect the GND pin to the ground plane using short, low-impedance paths. The AVDD supply voltage also functions as the reference voltage for the ADS7128. Place the decoupling capacitor for AVDD close to the device AVDD and GND pins and connect the decoupling capacitor to the device pins with thick copper tracks.

11.2 Layout Example

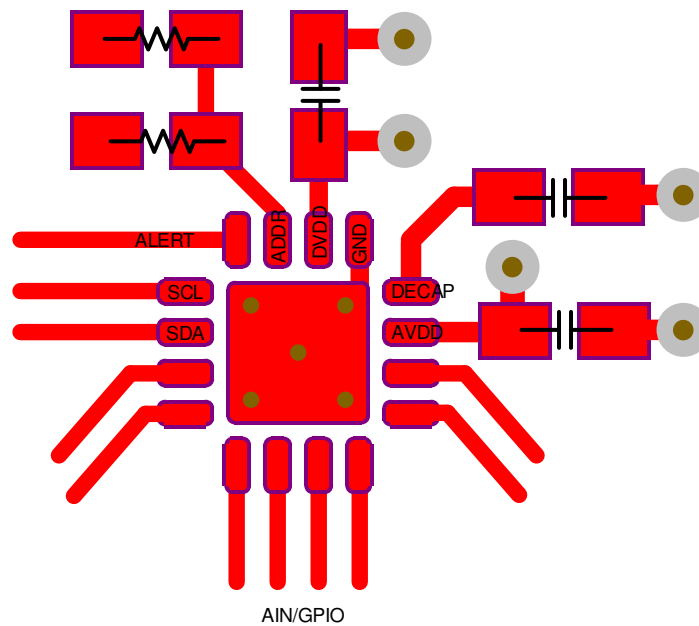

Figure 161. Example Layout

12 Device and Documentation Support

12.1 Receiving Notification of Documentation Updates

To receive notification of documentation updates, navigate to the device product folder on ti.com. In the upper right corner, click on *Alert me* to register and receive a weekly digest of any product information that has changed. For change details, review the revision history included in any revised document.

12.2 Support Resources

TI E2E™ [support forums](#) are an engineer's go-to source for fast, verified answers and design help — straight from the experts. Search existing answers or ask your own question to get the quick design help you need.

Linked content is provided "AS IS" by the respective contributors. They do not constitute TI specifications and do not necessarily reflect TI's views; see TI's [Terms of Use](#).

12.3 Trademarks

E2E is a trademark of Texas Instruments.
All other trademarks are the property of their respective owners.

12.4 Electrostatic Discharge Caution



This integrated circuit can be damaged by ESD. Texas Instruments recommends that all integrated circuits be handled with appropriate precautions. Failure to observe proper handling and installation procedures can cause damage.

ESD damage can range from subtle performance degradation to complete device failure. Precision integrated circuits may be more susceptible to damage because very small parametric changes could cause the device not to meet its published specifications.

12.5 Glossary

[SLYZ022](#) — *TI Glossary*.

This glossary lists and explains terms, acronyms, and definitions.

13 Mechanical, Packaging, and Orderable Information

The following pages include mechanical, packaging, and orderable information. This information is the most current data available for the designated devices. This data is subject to change without notice and revision of this document. For browser-based versions of this data sheet, refer to the left-hand navigation.

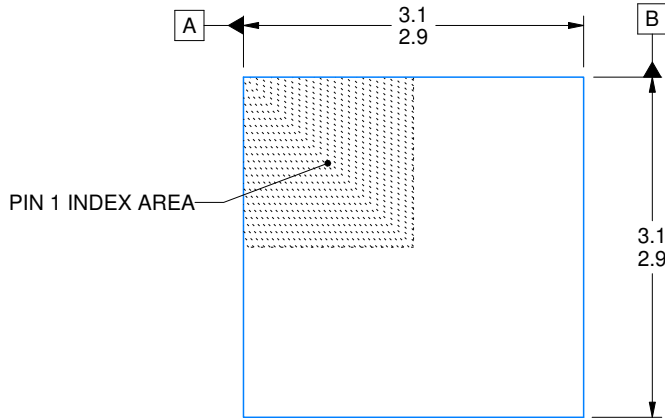

SIDE WALL METAL THICKNESS DIM A	
OPTION 1	OPTION 2
0.1	0.2

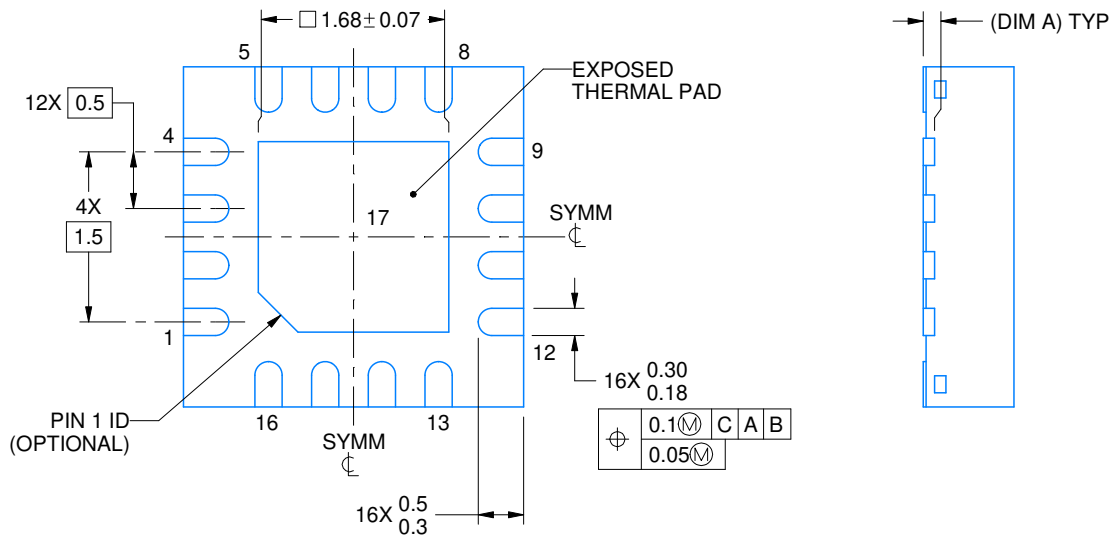
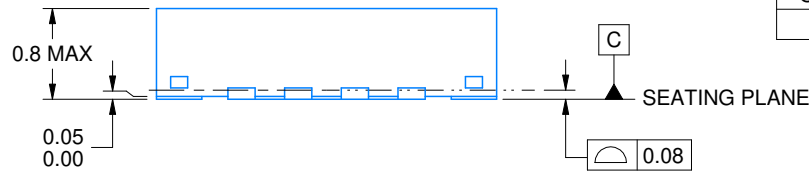

4219117/B 04/2022

NOTES:

1. All linear dimensions are in millimeters. Any dimensions in parenthesis are for reference only. Dimensioning and tolerancing per ASME Y14.5M.
2. This drawing is subject to change without notice.
3. The package thermal pad must be soldered to the printed circuit board for thermal and mechanical performance.

EXAMPLE STENCIL DESIGN

RTE0016C

WQFN - 0.8 mm max height

PLASTIC QUAD FLATPACK - NO LEAD

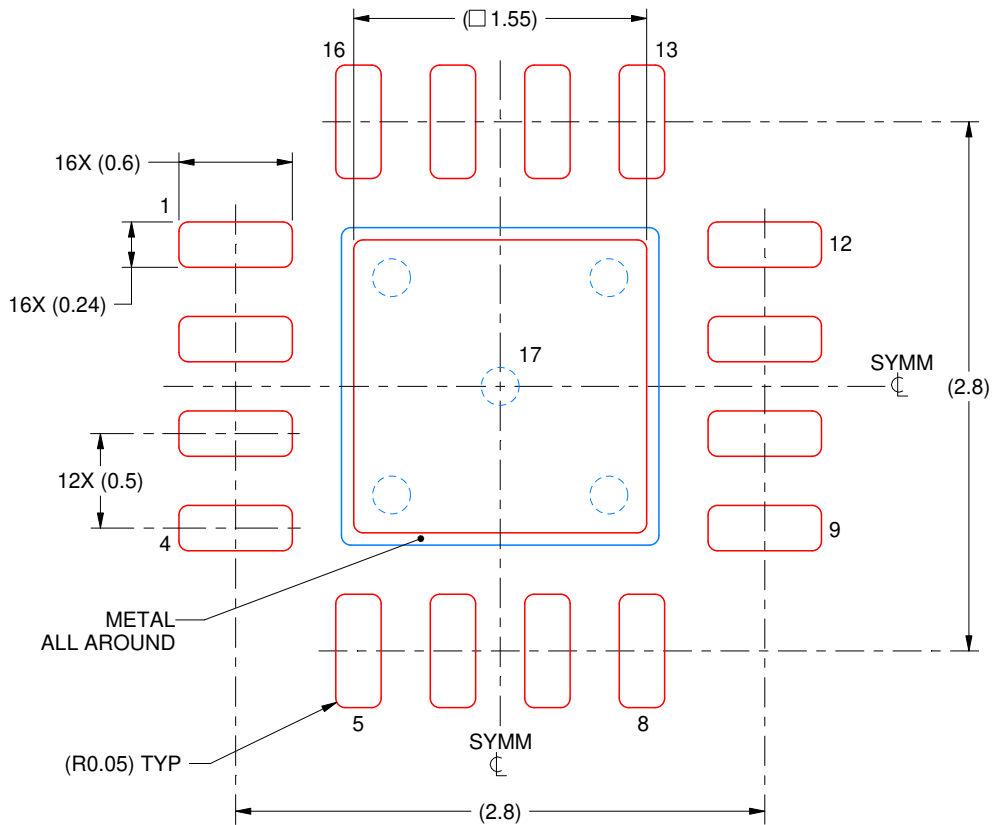

SOLDER PASTE EXAMPLE
BASED ON 0.125 mm THICK STENCIL

EXPOSED PAD 17:
85% PRINTED SOLDER COVERAGE BY AREA UNDER PACKAGE
SCALE:25X

4219117/B 04/2022

NOTES: (continued)

6. Laser cutting apertures with trapezoidal walls and rounded corners may offer better paste release. IPC-7525 may have alternate design recommendations.

PACKAGING INFORMATION

Orderable Device	Status (1)	Package Type	Package Drawing	Pins	Package Qty	Eco Plan (2)	Lead finish/ Ball material (6)	MSL Peak Temp (3)	Op Temp (°C)	Device Marking (4/5)	Samples
ADS7128IRTER	ACTIVE	WQFN	RTE	16	3000	RoHS & Green	NIPDAU	Level-1-260C-UNLIM	-40 to 85	X71X8	Samples
ADS7128IRTET	ACTIVE	WQFN	RTE	16	250	RoHS & Green	NIPDAU	Level-1-260C-UNLIM	-40 to 85	X71X8	Samples

(1) The marketing status values are defined as follows:

ACTIVE: Product device recommended for new designs.

LIFEBUY: TI has announced that the device will be discontinued, and a lifetime-buy period is in effect.

NRND: Not recommended for new designs. Device is in production to support existing customers, but TI does not recommend using this part in a new design.

PREVIEW: Device has been announced but is not in production. Samples may or may not be available.

OBSOLETE: TI has discontinued the production of the device.

(2) **RoHS:** TI defines "RoHS" to mean semiconductor products that are compliant with the current EU RoHS requirements for all 10 RoHS substances, including the requirement that RoHS substance do not exceed 0.1% by weight in homogeneous materials. Where designed to be soldered at high temperatures, "RoHS" products are suitable for use in specified lead-free processes. TI may reference these types of products as "Pb-Free".

RoHS Exempt: TI defines "RoHS Exempt" to mean products that contain lead but are compliant with EU RoHS pursuant to a specific EU RoHS exemption.

Green: TI defines "Green" to mean the content of Chlorine (Cl) and Bromine (Br) based flame retardants meet JS709B low halogen requirements of <=1000ppm threshold. Antimony trioxide based flame retardants must also meet the <=1000ppm threshold requirement.

(3) MSL, Peak Temp. - The Moisture Sensitivity Level rating according to the JEDEC industry standard classifications, and peak solder temperature.

(4) There may be additional marking, which relates to the logo, the lot trace code information, or the environmental category on the device.

(5) Multiple Device Markings will be inside parentheses. Only one Device Marking contained in parentheses and separated by a "~" will appear on a device. If a line is indented then it is a continuation of the previous line and the two combined represent the entire Device Marking for that device.

(6) Lead finish/Ball material - Orderable Devices may have multiple material finish options. Finish options are separated by a vertical ruled line. Lead finish/Ball material values may wrap to two lines if the finish value exceeds the maximum column width.

Important Information and Disclaimer:The information provided on this page represents TI's knowledge and belief as of the date that it is provided. TI bases its knowledge and belief on information provided by third parties, and makes no representation or warranty as to the accuracy of such information. Efforts are underway to better integrate information from third parties. TI has taken and continues to take reasonable steps to provide representative and accurate information but may not have conducted destructive testing or chemical analysis on incoming materials and chemicals. TI and TI suppliers consider certain information to be proprietary, and thus CAS numbers and other limited information may not be available for release.

In no event shall TI's liability arising out of such information exceed the total purchase price of the TI part(s) at issue in this document sold by TI to Customer on an annual basis.

TAPE AND REEL INFORMATION

QUADRANT ASSIGNMENTS FOR PIN 1 ORIENTATION IN TAPE

*All dimensions are nominal

Device	Package Type	Package Drawing	Pins	SPQ	Reel Diameter (mm)	Reel Width W1 (mm)	A0 (mm)	B0 (mm)	K0 (mm)	P1 (mm)	W (mm)	Pin1 Quadrant
ADS7128IRTER	WQFN	RTE	16	3000	330.0	12.4	3.3	3.3	1.1	8.0	12.0	Q2
ADS7128IRTET	WQFN	RTE	16	250	180.0	12.4	3.3	3.3	1.1	8.0	12.0	Q2

TAPE AND REEL BOX DIMENSIONS

*All dimensions are nominal

Device	Package Type	Package Drawing	Pins	SPQ	Length (mm)	Width (mm)	Height (mm)
ADS7128IRTER	WQFN	RTE	16	3000	367.0	367.0	35.0
ADS7128IRTET	WQFN	RTE	16	250	210.0	185.0	35.0

GENERIC PACKAGE VIEW

RTE 16

WQFN - 0.8 mm max height

3 x 3, 0.5 mm pitch

PLASTIC QUAD FLATPACK - NO LEAD

This image is a representation of the package family, actual package may vary.
Refer to the product data sheet for package details.

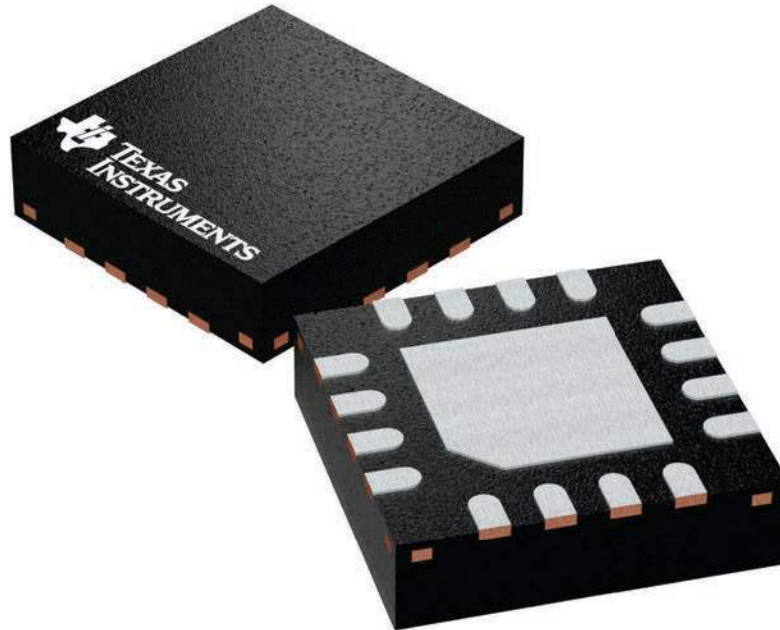

4225944/A

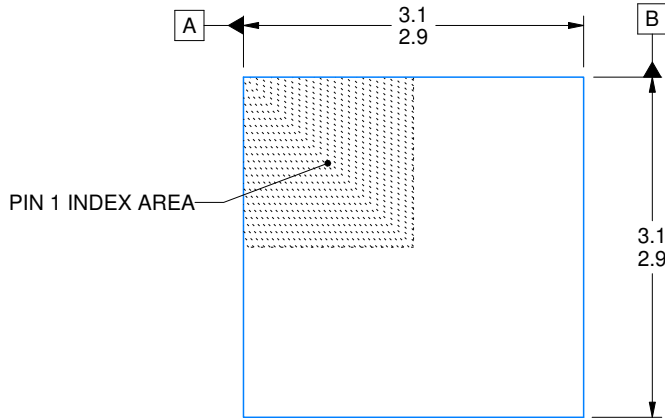

SIDE WALL METAL THICKNESS DIM A	
OPTION 1	OPTION 2
0.1	0.2

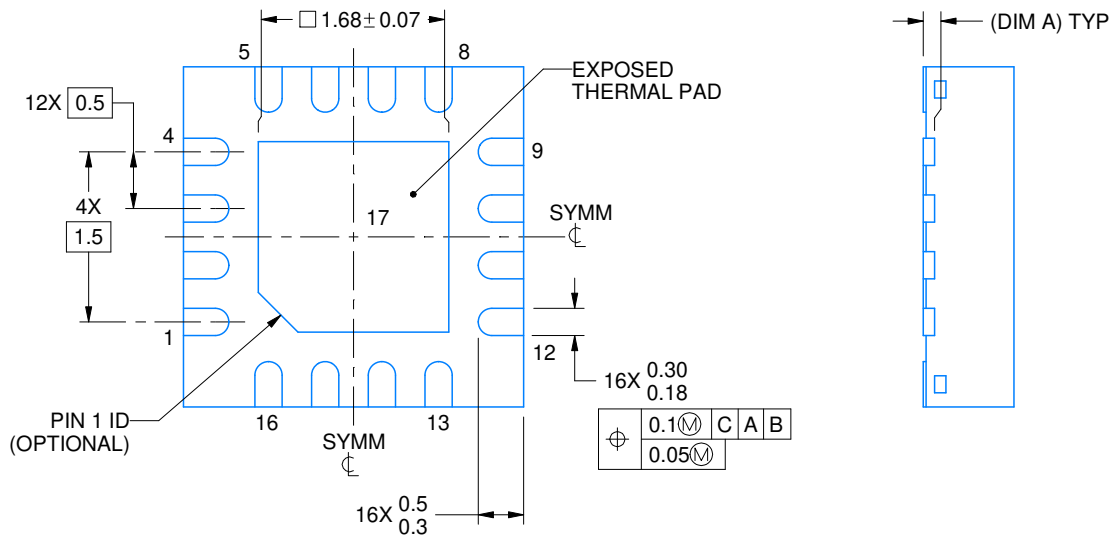
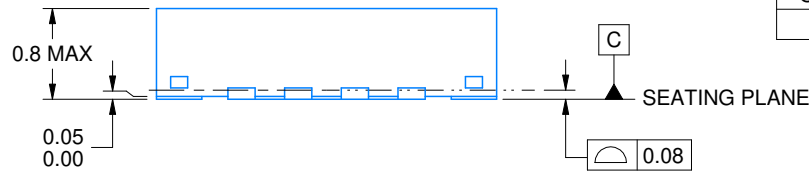

4219117/B 04/2022

NOTES:

1. All linear dimensions are in millimeters. Any dimensions in parenthesis are for reference only. Dimensioning and tolerancing per ASME Y14.5M.
2. This drawing is subject to change without notice.
3. The package thermal pad must be soldered to the printed circuit board for thermal and mechanical performance.

EXAMPLE BOARD LAYOUT

RTE0016C

WQFN - 0.8 mm max height

PLASTIC QUAD FLATPACK - NO LEAD

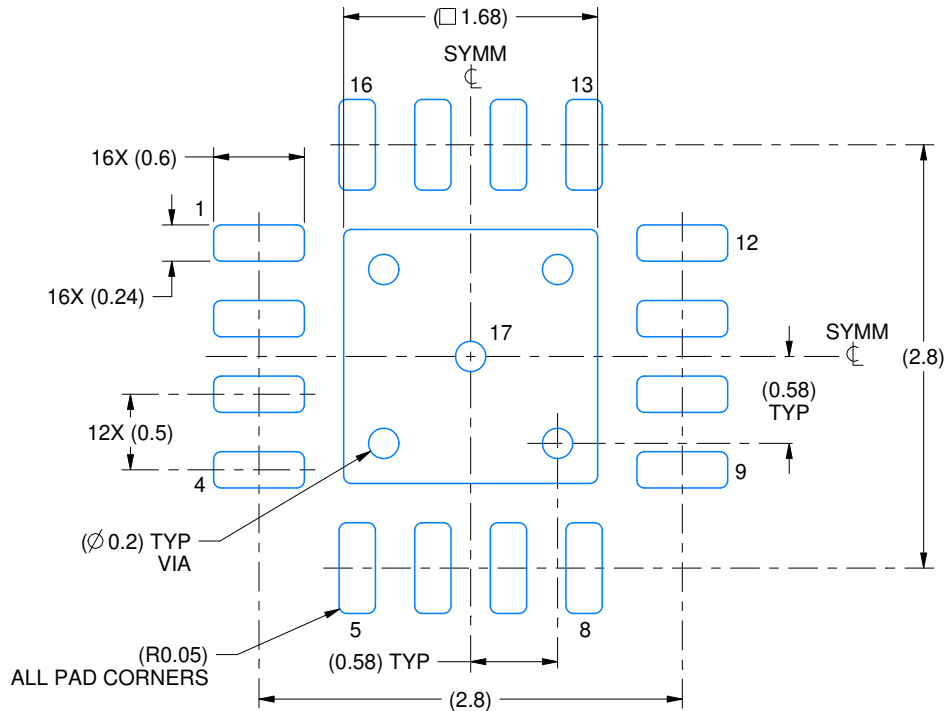

LAND PATTERN EXAMPLE
EXPOSED METAL SHOWN
SCALE:20X

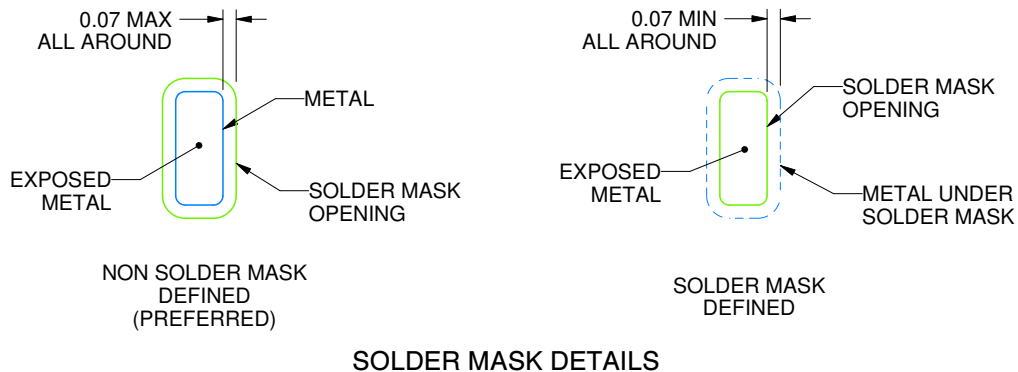

SOLDER MASK DETAILS

4219117/B 04/2022

NOTES: (continued)

- This package is designed to be soldered to a thermal pad on the board. For more information, see Texas Instruments literature number SLUA271 (www.ti.com/lit/slua271).
- Vias are optional depending on application, refer to device data sheet. If any vias are implemented, refer to their locations shown on this view. It is recommended that vias under paste be filled, plugged or tented.

EXAMPLE STENCIL DESIGN

RTE0016C

WQFN - 0.8 mm max height

PLASTIC QUAD FLATPACK - NO LEAD

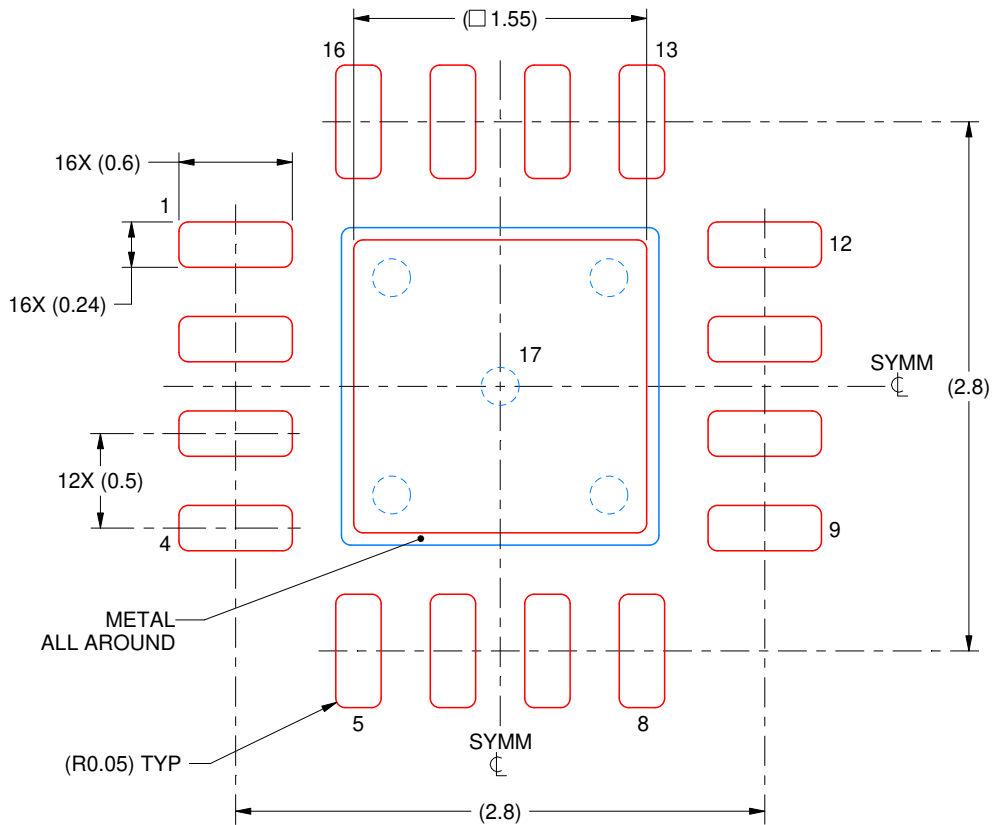

SOLDER PASTE EXAMPLE
BASED ON 0.125 mm THICK STENCIL

EXPOSED PAD 17:
85% PRINTED SOLDER COVERAGE BY AREA UNDER PACKAGE
SCALE:25X

4219117/B 04/2022

NOTES: (continued)

6. Laser cutting apertures with trapezoidal walls and rounded corners may offer better paste release. IPC-7525 may have alternate design recommendations.

IMPORTANT NOTICE AND DISCLAIMER

TI PROVIDES TECHNICAL AND RELIABILITY DATA (INCLUDING DATA SHEETS), DESIGN RESOURCES (INCLUDING REFERENCE DESIGNS), APPLICATION OR OTHER DESIGN ADVICE, WEB TOOLS, SAFETY INFORMATION, AND OTHER RESOURCES "AS IS" AND WITH ALL FAULTS, AND DISCLAIMS ALL WARRANTIES, EXPRESS AND IMPLIED, INCLUDING WITHOUT LIMITATION ANY IMPLIED WARRANTIES OF MERCHANTABILITY, FITNESS FOR A PARTICULAR PURPOSE OR NON-INFRINGEMENT OF THIRD PARTY INTELLECTUAL PROPERTY RIGHTS.

These resources are intended for skilled developers designing with TI products. You are solely responsible for (1) selecting the appropriate TI products for your application, (2) designing, validating and testing your application, and (3) ensuring your application meets applicable standards, and any other safety, security, regulatory or other requirements.

These resources are subject to change without notice. TI grants you permission to use these resources only for development of an application that uses the TI products described in the resource. Other reproduction and display of these resources is prohibited. No license is granted to any other TI intellectual property right or to any third party intellectual property right. TI disclaims responsibility for, and you will fully indemnify TI and its representatives against, any claims, damages, costs, losses, and liabilities arising out of your use of these resources.

TI's products are provided subject to [TI's Terms of Sale](#) or other applicable terms available either on ti.com or provided in conjunction with such TI products. TI's provision of these resources does not expand or otherwise alter TI's applicable warranties or warranty disclaimers for TI products.

TI objects to and rejects any additional or different terms you may have proposed.

Mailing Address: Texas Instruments, Post Office Box 655303, Dallas, Texas 75265
Copyright © 2022, Texas Instruments Incorporated