

REV.	DATE	DESCRIPTION
A	05/03/2010	RELEASE TO MFG.

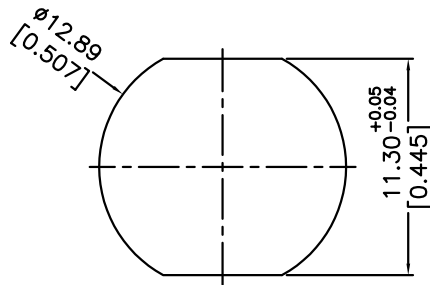

RECOMMENDED MOUNTING HOLE DIMENSIONS

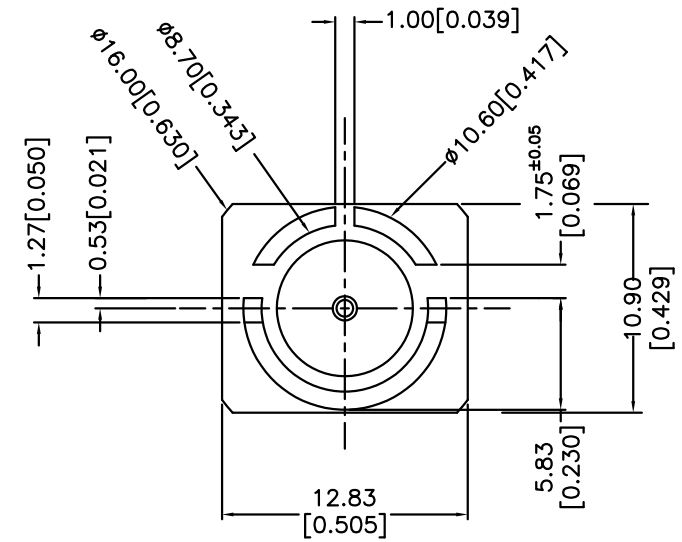
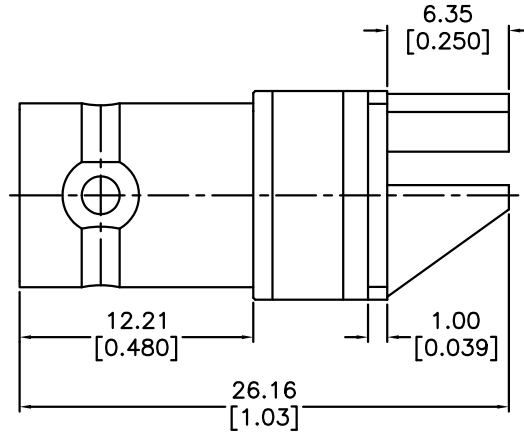
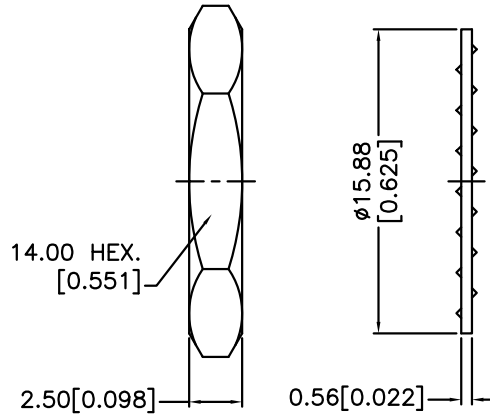
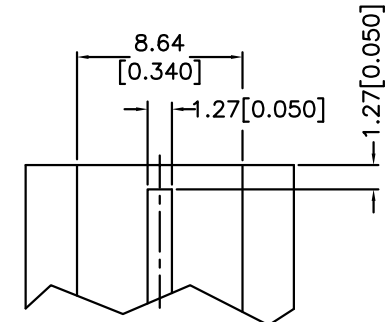
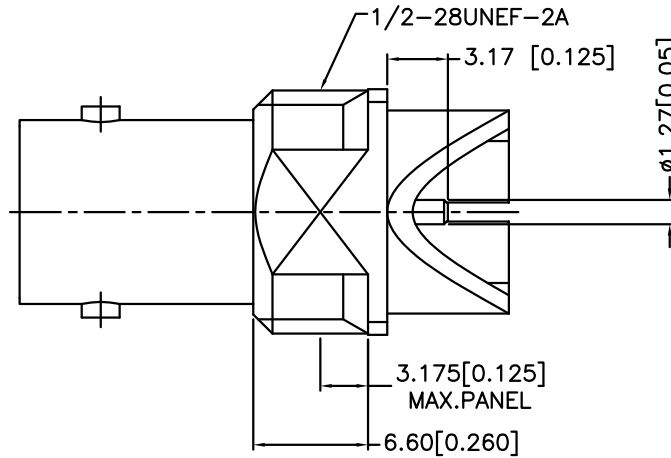

RECOMMENDED PCB LAYOUT

NOTES: FINISH (PLATING THICKNESS IN MICRO-INCHES)

NO	DESCRIPTION	MATERIAL	FINISH	QTY	DO NOT SCALE DRAWING	APPROVALS	DATE	AMPHENOL CONNEX				
6	HEX NUT	BRASS	NICKEL	1	<small>UNLESS OTHERWISE SPECIFIED DIMENSIONS ARE IN MILLIMETERS. DIMENSIONS IN [] ARE IN INCHES AND FOR CUSTOMER REFERENCE ONLY.</small> <small>UNLESS OTHERWISE SPECIFIED TOLERANCES FOR MILLIMETERS ARE:</small> 0.5 - 8mm ± 0.20mm 8 - 30mm ± 0.40mm 30 - 120mm ± 0.50mm <small>UNLESS OTHERWISE SPECIFIED TOLERANCES FOR INCHES ARE:</small> .020 - .315 = ± 0.007" .315 - 1.180 = ± 0.015" 1.180 - 4.724 = ± 0.020"	DRAWN	CLEMENT	05/03/2010	BNC END LAUNCH RECEPTACLE JACK, 75 OHMS EXTENDED THREADS			
5	LOCK WASHER	BRASS	NICKEL	1		CHECKED						
4	HOUSING	BRASS	GOLD	1		ISSUED						
3	CONTACT PIN	PHOSPHOR BRONZE	GOLD	1		SHEET	1 OF 1		PART NO. 112740-20			
2	INSULATOR	TEFLON	NATURAL	1					DWG. NO. 112740-20.DWG			
1	BODY	BRASS	GOLD	1					REV. A	SIZE A	SCALE NA	