

March 1997

CMOS Static Clock Controller/Generator

Features

- Generates the System Clock For CMOS or NMOS Microprocessors and Peripherals
- Complete Control Over System Operation for Very Low System Power
 - Stop-Oscillator
 - Low Frequency
 - Stop-Clock
 - Full Speed Operation
- DC to 25MHz Operation (DC to 8MHz System Clock)
- Generates 50% and 33% Duty Cycle Clocks (Synchronized)
- Uses a Parallel Mode Crystal Circuit or External Frequency Source
- TTL Compatible Inputs/Outputs
- 24 Lead Slimline Dual-In-Line or 28 Pad Square LCC Package Options
- Single 5V Power Supply
- Operating Temperature Range
 - C82C85 0°C to +70°C
 - I82C85 -40°C to +85°C
 - M82C85 -55°C to +125°C

Description

The Harris 82C85 Static CMOS Clock Controller/Generator provides complete control of static CMOS system operating modes and supports full speed, slow, stop-clock and stop-oscillator operation. While directly compatible with the Harris 80C86 and 80C88 16-bit Static CMOS Microprocessor Family, the 82C85 can also be used for general system clock control.

For static system designs, separate signals are provided on the 82C85 for stop (S0, S1, S2/STOP) and start (START) control of the crystal oscillator and system clocks. A single control line (SLO/FST) determines 82C85 fast (crystal/EFI frequency divided by 3) or slow (crystal/EFI frequency divided by 768) mode operation. Automatic maximum mode 80C86 and 80C88 software HALT instruction decode logic in the 82C85 enables software-based clock control. Restart logic insures valid clock start-up and complete synchronization of system clocks.

The 82C85 is manufactured using the Harris advanced Scaled SAJI IV CMOS process. In addition to clock control circuitry, the 82C85 also contains a crystal controlled oscillator (up to 25MHz), clock generation logic, complete "Ready" synchronization and reset logic. This permits the designer to tailor the system power-performance product to provide optimum performance at low power levels.

Ordering Information

PART NUMBER	PACKAGE	TEMP. RANGE	PKG. NO.
CS82C85	28 Ld PLCC	0°C to +70°C	N28.45
IS82C85		-40°C to +85°C	N28.45
CD82C85	24 Ld CERDIP	0°C to +70°C	F24.3
ID82C85		-40°C to +85°C	F24.3
MD82C85/B		-55°C to +125°C	F24.3
MR82C85/B	28 Pad CLCC	-55°C to +125°C	J28.A

Pinouts

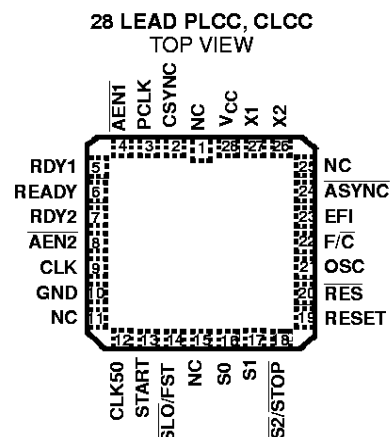
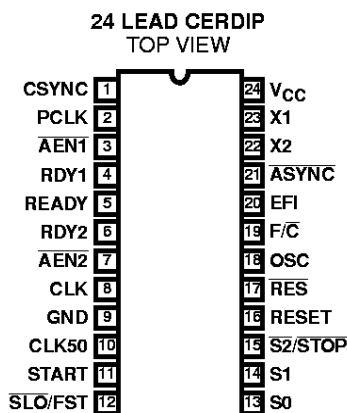

82C85

Pin Descriptions

SYMBOL	DIP PIN NUMBER	TYPE	DESCRIPTION
X1 X2	23 22	I O	CRYSTAL CONNECTIONS: X1 and X2 are the crystal oscillator connections. The crystal frequency must be 3 times the maximum desired processor clock frequency. X1 is the oscillator circuit input and X2 is the output of the oscillator circuit. If the crystal inputs are not used, X1 must be tied to V_{CC} or GND, and X2 should be left open.
EFI	20	I	EXTERNAL FREQUENCY IN: When F/\bar{C} is HIGH, CLK is generated from the EFI input signal. This input signal should be a square wave with a frequency of three times the maximum desired CLK output frequency. If the crystal inputs are not used, X1 must be tied to V_{CC} or GND, and X2 should be left open.
F/\bar{C}	19	I	FREQUENCY/CRYSTAL SELECT: F/\bar{C} selects either the crystal oscillator or the EFI input as the main frequency source. When F/\bar{C} is LOW, the 82C85 clocks are derived from the crystal oscillator circuit. When F/\bar{C} is HIGH, CLK is generated from the EFI input. F/\bar{C} cannot be dynamically switched during normal operation.
START	11	I	A low-to-high transition on START will restart the CLK, CLK50 and PCLK outputs after the appropriate restart sequence is completed. When in the crystal mode (F/\bar{C} LOW) with the oscillator stopped. The oscillator will be restarted when a Start command is received. The CLK, CLK50 and PCLK outputs will start after the oscillator input signal (X1) reaches the Schmitt trigger input threshold and 8K internal counter reaches terminal count. If F/\bar{C} is HIGH (EFI mode), CLK, CLK50 and PCLK will restart within 3 EFI cycles after START is recognized. The 82C85 will restart in the same mode (\bar{SLO}/FST) in which it stopped. A high level on START disables the STOP mode.
SO S1 $\bar{S2}/STOP$	13 14 15	I I I	$\bar{S2}/STOP$, S1, SO are used to stop the 82C85 clock outputs (CLK, CLK50, PCLK) and are sampled by the rising edge of CLK. CLK50 and PCLK are stopped by $\bar{S2}/STOP$, S1, SO being in the LHH state on the low-to-high transition of CLK. This LHH state must follow a passive HHH state occurring on the previous low-to-high CLK transition. CLK and CLK50 stop in the high state when F/\bar{C} is low and may stop in either the high or low state when F/\bar{C} is high. PCLK stops in its current state (high or low). When in the crystal mode (F/\bar{C} low) and a STOP command is issued, the 82C85 oscillator will stop along with the CLK, CLK50 and PCLK outputs. When in the EFI mode, only the CLK, CLK50 and PCLK outputs will be halted. The oscillator circuit if operational, will continue to run. The oscillator and/or clock is restarted by the START input signal going true (HIGH) or the reset input (\bar{RES}) going low.
\bar{SLO}/FST	12	I	\bar{SLO}/FST is a level-triggered input. When HIGH, the CLK and CLK50 outputs run at the maximum frequency (crystal or EFI frequency divided by 3). When LOW, CLK and CLK50 frequencies are equal to the crystal or EFI frequency divided by 768. \bar{SLO}/FST changes are internally synchronized so proper CLK and CLK50 phase relationships are maintained and minimum pulse width specifications are met. START and STOP control of the oscillator or EFI is available in either the SLOW or FAST frequency modes. The \bar{SLO}/FST input must be held LOW for at least 195 OSC/EFI clock cycles before it will be recognized. This eliminates unwanted frequency changes which could be caused by glitches or noise transients. The \bar{SLO}/FST input must be held HIGH for at least 6 OSC/EFI clock pulses to guarantee a transition to FAST mode operation.
CLK	8	O	PROCESSOR CLOCK: CLK is the clock output used by the 80C86 or 80C88 processor and other peripheral devices. When \bar{SLO}/FST is high, CLK has an output frequency which is equal to the crystal or EFI input frequency divided by three. When \bar{SLO}/FST is low, CLK has an output frequency which is equal to the crystal or EFI input frequency divided by 768. CLK has a 33% duty cycle.
CLK50	10	O	50% DUTY CYCLE CLOCK: CLK50 is an auxiliary clock with a 50% duty cycle and is synchronized to the falling edge of CLK. When \bar{SLO}/FST is high, CLK50 has an output frequency which is equal to the crystal or EFI input frequency divided by 3. When \bar{SLO}/FST is low, CLK50 has an output frequency equal to the crystal or EFI input frequency divided by 768.
PCLK	2	O	PERIPHERAL CLOCK: PCLK is a peripheral clock signal whose output frequency is equal to the crystal or EFI input frequency divided by 6 and has a 50% duty cycle. PCLK frequency is unaffected by the state of the \bar{SLO}/FST input.
OSC	18	O	OSCILLATOR OUTPUT: OSC is the output of the internal oscillator circuitry. Its frequency is equal to that of the crystal oscillator circuit. OSC is unaffected by the state of the \bar{SLO}/FST input. When the 82C85 is in the crystal mode (F/\bar{C} low) and a STOP command is issued, the OSC output will stop in the HIGH state. When the 82C85 is in the EFI mode (F/\bar{C} HIGH, the oscillator (if operational) will continue to run when a STOP command is issued and OSC remains active.

Pin Descriptions (Continued)

SYMBOL	DIP PIN NUMBER	TYPE	DESCRIPTION
RES	17	I	RESET IN: RES is an active LOW signal which is used to generate RESET. The 82C85 provides a Schmitt trigger input so that an RC connection can be used to establish the power-up reset of proper duration. \overline{RES} starts crystal oscillator operation.
RESET	16	O	RESET: RESET is an active HIGH signal which is used to reset the 80C86 family processors. Its timing characteristics are determined by RES. RESET is guaranteed to be HIGH for a minimum of 16 CLK pulses after the rising edge of RES.
CSYNC	1	I	CLOCK SYNCHRONIZATION: CSYNC is an active HIGH signal which allows multiple 82C85 and 82C84A to be synchronized to provide multiple in-phase clock signals. When CSYNC is HIGH, the internal counters are reset and force CLK, CLK50 and PCLK into a HIGH state. When CSYNC is LOW, the internal counters are allowed to count and the CLK, CLK50 and PCLK outputs are active. CSYNC must be externally synchronized to EFI.
AEN1 AEN2	3 7	I	ADDRESS ENABLE: AEN is an active LOW signal. AEN serves to qualify its respective Bus Ready Signal (RDY1 or RDY2). AEN1 validates RDY1 while AEN2 validates RDY2. Two AEN signal inputs are useful in system configurations which permit the processor to access two Multi-Master System Buses.
RDY1 RDY2	4 6	I	BUS READY: (Transfer Complete). RDY is an active HIGH signal which is an indication from a device located on the system data bus that data has been received, or is available. RDY1 is qualified by AEN1 while RDY2 is qualified by AEN2.
ASYNC	21	I	READY SYNCHRONIZATION SELECT: ASYNC is an input which defines the synchronization mode of the READY logic. When ASYNC is LOW, two stages of READY synchronization are provided. When \overline{ASYNC} is left open or HIGH a single stage of READY synchronization is provided.
READY	5	O	READY: READY is an active HIGH signal which is the synchronized RDY signal input.
GND	9	I	Ground
V _{CC}	24	I	V _{CC} : is the +5V power supply pin. A 0.1mF capacitor between V _{CC} and GND is recommended.

Functional Block Diagram

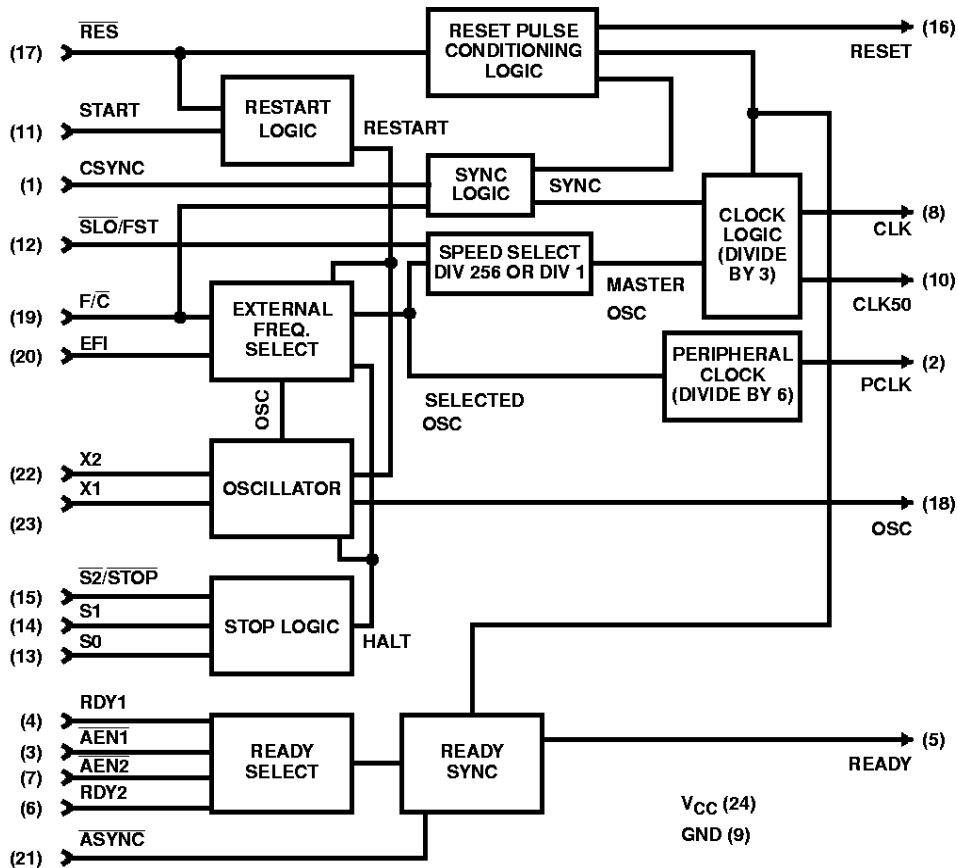

Functional Description

The 82C85 Static Clock Controller/Generator provides simple and complete control static CMOS system operating modes. The 82C85 supports full speed, slow, stop-clock and stop-oscillator operation. While it is directly compatible with the Harris 80C86 and 80C88 CMOS 16-bit static microprocessors, the 82C85 can also be used for general purpose system clock control.

The 82C85 pinout is a superset of the 82C84A Clock Generator/Driver. 82C85 pins 1-9, 16-24 are compatible with 82C84A pins 1-9, 10-18 respectively. An 82C84A can be placed in the upper 18 pins of an 82C85 socket and it will operate correctly (without the ability to control the clock and oscillator operation.) This allows dual design for simple system upgrades. The 82C85 will also emulate an 82C84A when pins 11-15 on the 82C85 are tied to V_{CC} .

For static systems designs, separate signals are provided on the 82C85 for stop and start control of the crystal oscillator and clock outputs. A single control line determines 82C85 fast (crystal/EFI frequency divided by 3) or slow (crystal/EFI frequency divided by 768) mode operation. The 82C85 also contains a crystal controlled oscillator, clock generation logic, complete "Ready" synchronization and reset logic.

Automatic 80C86/88 software HALT instruction decode logic is present to ease the design of software-based clock control systems and provide complete software control of STOP mode operation. Restart logic insures valid clock start-up and complete synchronization of CLK, CLK50 and PCLK.

Static Operating Modes

In static CMOS system design, there are four basic operating modes. The 82C85 Static Clock Controller supports each of them. These modes are: FAST, SLOW, STOP-CLOCK and STOP-OSCILLATOR. Each has distinct power and performance characteristics which can be matched to the needs of a particular system at a specific time (See Table 1).

Keep in mind that a single system may require all of these operating modes at one time or another during normal operation. A design need not be limited to a single operating mode or a specific combination of modes. The appropriate operating mode can be matched to the power-performance level needed at a specific time or in a particular circumstance.

Reset Logic

The 82C85 reset logic provides a Schmitt trigger input (\overline{RES}) and a synchronizing flip-flop to generate the reset timing. The reset signal is synchronized to the falling edge of CLK. A simple RC network can be used to provide power-on reset by utilizing this function of the 82C85.

When in the crystal oscillator ($F/\overline{C} = \text{LOW}$) or the EFI ($F/\overline{C} = \text{HIGH}$) mode, a LOW state on the RES input will set the RESET output to the HIGH state. It will also restart the oscillator circuit if it is in the idle state. The RESET output is guaranteed to stay in the HIGH state for a minimum of 16 CLK cycles after a low-to-high transition of the RES input.

An oscillator restart count sequence will not be disturbed by RESET if this count is already in progress. After the restart counter expires, the RESET output will stay HIGH at least for 16 periods of CLK before going LOW. RESET can be kept high beyond this time by a continuing low input on the RES input.

If F/\overline{C} is low (crystal oscillator mode), a low state on \overline{RES} starts the crystal oscillator circuit. The stopped outputs remain inactive, until the oscillator signal amplitude reaches the X1 Schmitt trigger input threshold voltage and 8192 cycles of the crystal oscillator output are counted by an internal counter. After this count is complete, the stopped outputs (CLK, CLK50, PCLK, and OSC) start cleanly with the proper phase relationships.

This 8192 count requirement insures that the CLK, CLK50 and PCLK outputs will meet minimum clock requirements and will not be affected by unstable oscillator characteristics which may exist during the oscillator start-up sequence. This sequence is also followed when a START command is issued while the 82C85 oscillator is stopped.

Oscillator/Clock Start Control

Once the oscillator is stopped (or committed to stop) or at power-on, the restart sequence is initiated by a HIGH state on START or LOW state on \overline{RES} . If F/\overline{C} is HIGH, then restart occurs immediately after the START or RES input is synchronized internally. This insures that stopped outputs (CLK, PCLK, OSC and CLK50) start cleanly with the proper phase relationship.

If F/\overline{C} is low (crystal oscillator mode), a HIGH state on the START input or a low state on \overline{RES} causes the crystal oscillator to be restarted. The stopped outputs remain stopped,

TABLE 1. STATIC SYSTEM OPERATING MODE CHARACTERISTICS

OPERATING MODE	DESCRIPTION	POWER LEVEL	PERFORMANCE
Stop-Oscillator	All system clocks and main clock oscillator are stopped	Maximum Savings	Slowest response due to oscillator restart time
Stop-Clock	System CPU and peripherals clocks stop but main clock oscillator continues to run at rated frequency	Reduced System Power	Fast restart-no oscillator restart time
Slow	System CPU clocks are slowed while peripheral clock and main clock oscillator run at rated frequency	Power Dissipation Slightly Higher Than Stop-Clock	Continuous operation at low frequency
Fast	All clocks and oscillators run at rated frequency	Highest Power	Fastest response

82C85

until the oscillator signal amplitude reaches the X1 Schmitt trigger input threshold voltage and 8192 cycles of the crystal oscillator output are counted by an internal counter. After this count is complete, the stopped outputs (CLK, CLK50, PCLK, and OSC) start cleanly with the proper phase relationships.

Typically, any input signal which meets the START input timing requirements can be used to start the 82C85. In many cases, this would be the INT output from an 82C59A CMOS Priority Interrupt Controller (See Figure 1). This output, which is active high, can be connected to both the 82C85 START pin and to the appropriate interrupt request input on the microprocessor.

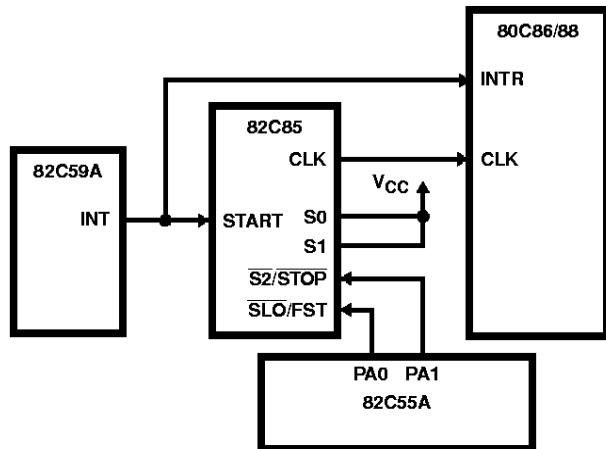

FIGURE 1. CMOS PERIPHERAL CONTROL OF 82C85 STOP, START AND SLOW/FAST OPERATIONS

When the INT output becomes active, the oscillator/clock circuit on the 82C85 will restart. Upon completion of the appropriate restart sequence, the CLK signal to the CPU will become active. The CPU can then respond to the still pending interrupt request.

If the 82C59A/82C85 restart combination is used in conjunction with an 82C55A STOP control, the 82C55A must be initialized prior to the 82C59A after reset. The 82C59A interrupt output is driven high at reset, causing the 82C85 to remain in the START mode regardless of the state of the S2/STOP input. This will avoid stopping the 82C85 due to negative transitions on the S2/STOP input which may occur during a mode change on the 82C55A or during the operation of any peripheral I/O device prior to initialization.

Another method of insuring proper operation of the START function upon reset or system initialization is to bias the S2/STOP input low with an external pull-down resistor. The S2/STOP input will remain low until driven high by the 82C55A port pin or by external logic. This insures that the 82C85 STOP command (HHH prior to LHH requirement on the status inputs) will not be satisfied. To minimize power dissipation in this case (using a pulldown resistor), the S2/STOP input should be normally LOW and pulsed HIGH to develop the necessary HHH-to-LHH STOP sequence. In this manner, the output driving the S2/STOP input will be normally LOW and will not be driving to the opposite state of the pull-down resistor.

Fast Mode

The most common operating mode for a system is the FAST mode. In this mode, the 82C85 operates at the maximum frequency determined by the main oscillator or EFI frequency.

TABLE 2. TYPICAL SYSTEM POWER SUPPLY CURRENT FOR STATIC CMOS OPERATING MODES

	FAST	SLOW	STOP-CLOCK	STOP-OSC
CPU Frequency	5MHz	20 KHz	DC	DC
XTAL Frequency	15MHz	15MHz	15MHz	DC
ICC				
82C85	24.7mA	16.9mA	14.1mA	24.4mA
80C88	23.8mA	173.0mA	106.6mA	106.6mA
82C82	1.7mA	6.5mA	1.0mA	1.0mA
82C86	1.4mA	14.0mA	1.0mA	1.0mA
82C88	3.5mA	14.3mA	3.8mA	3.8mA
82C52	151.2mA	72.0mA	1.0mA	1.0mA
82C54	943.0mA	915.0mA	3.5mA	1.0mA
82C55A	3.2mA	1.2mA	1.0mA	1.0mA
82C59A	580.0mA	520.0mA	1.0mA	1.0mA
74HCXX + other	2.9mA	10.0mA	90.0mA	90.0mA
HM-6516	820.0mA	32.0mA	1.9mA	1.9mA
HM-6616	6.3mA	52.5mA	12.0mA	12.0mA
Total	66.8mA	18.9mA	14.3mA	244.7mA

All measurements taken at room temperature, $V_{CC} = +5.0V$. Power supply current levels will be dependent upon system configuration and frequency of operation.

FAST mode operation is enabled by each of two conditions:

- The $\overline{\text{SLO}}/\text{FST}$ input is HIGH and a START or reset command is issued
- The $\overline{\text{SLO}}/\text{FST}$ input is held HIGH for at least 6 oscillator or EFI cycles.

Alternate Operating Modes

Using alternate modes of operation (slow, stop-clock, stop-oscillator) will reduce the average system operating power dissipation in a static CMOS system (See Table 2). This does not mean that system speed or throughput must be reduced. When used appropriately, the slow, stopclock, stop-oscillator modes can make your design more power efficient while maintaining maximum system performance.

Stop-Oscillator Mode

When the 82C85 is stopped while in the crystal mode ($\overline{\text{F/C}}$ LOW), the oscillator, in addition to all system clock signals (CLK, CLK50 and PCLK), are stopped. CLK and CLK50 stop in the high state. PCLK stops in it's current state (high or low).

With the oscillator stopped, 82C85 power drops to it's lowest level. All clocks and oscillators are stopped. All devices in the system which are driven by the 82C85 go into the lowest power standby mode. The 82C85 also goes into standby and requires a power supply current of less than 100 μA .

Stop-Clock Mode

When the 82C85 is in the EFI mode ($\overline{\text{F/C}}$ HIGH) and a $\overline{\text{STOP}}$ command is issued, all system clock signals (CLK, CLK50, and PCLK) are stopped. CLK and CLK50 stop in the high state when $\overline{\text{F/C}}$ is low and may stop in either the high or low state when $\overline{\text{F/C}}$ is high. PCLK stops in its current state (high or low).

The 82C85 can also provide it's own EFI source simply by connecting the OSC output to the EFI input and pulling the $\overline{\text{F/C}}$ input HIGH. This puts the 82C85 into the External Frequency Mode using it's own oscillator as an external source signal (See Figure 2). In this configuration, when the 82C85 is stopped in the EFI mode, the oscillator continues to run. Only the clocks to the CPU and peripherals (CLK, CLK50 and PCLK) are stopped.

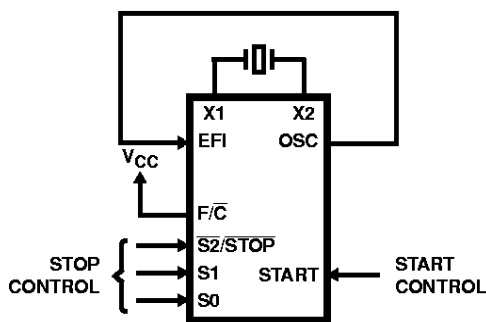

FIGURE 2. STOP-CLOCK MODE USING 82C85 IN EFI MODE WITH OSCILLATOR AS FREQUENCY SOURCE

Oscillator/Clock Stop Operation

Three control lines determine when the 82C85 clock outputs or oscillator will stop. These are S0, S1 and $\overline{\text{S2/STOP}}$. These three lines are designed to connect directly to the MAXimum mode 80C86 and 80C88 status lines or to be driven by external I/O signals (such as an 82C55A output port).

In the MAXimum mode configuration, the 82C85 will automatically recognize a software HALT command from the 80C86 or 80C88 and stop the system clocks or oscillator. This allows complete software control of the STOP function.

If the 80C86 or 80C88 is used in the MINimum mode, the 82C85 can be controlled using the $\overline{\text{S2/STOP}}$ input (with S0 and S1 held high). This can be done using an external I/O control line, such as from an 82C55A or by decoding the state of the 80C86 MINimum mode status signals.

82C85 status inputs $\overline{\text{S2/STOP}}$, S1, S0 are sampled on the rising edge of CLK. The oscillator ($\overline{\text{F/C}}$ LOW only) and clock outputs are stopped by $\overline{\text{S2/STOP}}$, S1, S0 being in the LHH state on a low-to-high transition of CLK. This LHH state must follow a passive HHH state occurring on the previous low-to-high CLK transition. CLK and CLK50 will stop in the logic HIGH state after two additional complete cycles of CLK. PCLK stops in it's current state (HIGH or LOW). This is true for both SLOW and FAST mode operation.

80C86/88 Maximum Mode Clock Control

The 82C85 STOP function has been optimized for 80C86/88 MAXimum mode operation. In this mode, the three 82C85 status inputs ($\overline{\text{S2/STOP}}$, S1, S0) are connected directly to the MAXimum mode status lines (S2, S1, S0) of the Harris 80C86 or 80C88 static CMOS microprocessors (See Figure 3).

When in the MAXimum mode, the 80C86/88 status lines identify which type of bus cycle the CPU is starting to execute. 82C85 $\overline{\text{S2/STOP}}$, S1 and S0 control input logic will recognize a valid MAXimum mode software HALT executed by the 80C86 or 80C88. Once this state has been recognized, the 82C85 stops the clock ($\overline{\text{F/C}}$ HIGH) and oscillator ($\overline{\text{F/C}}$ LOW) operation.

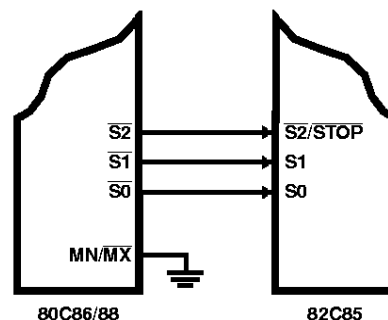

FIGURE 3. 82C85 STOP CONTROL USING 80C86/88 MAXIMUM MODE STATUS LINES

The 82C85 $\overline{S2}/\overline{STOP}$, S1 and S0 control lines were designed to detect a passive 111 state followed by a HALT 011 logic state before recognizing the HALT instruction and stopping the system clocks. In the MAXimum mode, the 80C86/88 status lines go into a passive (no bus cycle) logic 111 state prior to executing a HALT instruction. The qualification of a passive no bus cycle logic 111 state insures that random transitions of the status lines into a logic 011 state will not stop the system clock. This is necessary since the status lines of the 80C86/88 transition through an unknown state during T3 of the bus cycle.

Once the HALT instruction is decoded by the 82C85, either the oscillator is stopped (STOP-OSCILLATOR mode F/\overline{C} tied low) or the external frequency source is gated off internally (STOP-CLOCK mode F/\overline{C} HIGH). When the HALT instruction is decoded with F/\overline{C} low, the CLK and CLK50 will be stopped in a logic high state after 2 additional cycles of the clock. PCLK stops in it's current state (high or low). This is true for both SLOW and FAST mode operation. The HALT instruction is detected in the same manner whether the 82C85 is in the SLOW or FAST mode.

Independent Stop Control for Minimum Mode Operation

When the 80C86 and 80C88 microprocessors are configured in MINimum Mode (MN/ \overline{MX} pin tied high), their status lines S0, S1, and S2 assume alternate functions. The logic states and sequences (passive before a HALT) necessary for automatic HALT detect in the 82C85 do not occur as in the MAXimum mode. The 82C85 controller cannot use the microprocessor status lines to detect a software Halt instruction when operating in MINimum mode.

However, the negative edge-activated $\overline{S2}/\overline{STOP}$ pin provides a simple means for clock control in MINimum mode 80C86 and 80C88 systems. $\overline{S2}/\overline{STOP}$ can be used as an independent \overline{STOP} control when S1 and S0 are held in the logical HIGH state. Keeping the S0 and S1 inputs at a logic 1 level and transitioning $\overline{S2}/\overline{STOP}$ from high to low will meet the passive 111 state prior to a 011 state requirement of the 82C85. This feature allows 82C85 operation with the 80C86 and 80C88 in the MINimum mode, provides compatibility with other static CMOS microprocessors and allows maximum flexibility in a system.

With $\overline{S2}/\overline{STOP}$ being used as a stand-alone STOP command line, system clocks can be controlled via an 82C55A programmable peripheral interface or other similar interface circuits. This is accomplished by driving the $\overline{S2}/\overline{STOP}$ input with a PORT pin on the 82C55A (See Figure 1). The 82C55A port pin should be configured as an output and must present a logic HIGH to the $\overline{S2}/\overline{STOP}$ input for at least one CLK cycle, followed by a LOW state. This will meet the 82C85 status input requirement of 111 followed by a 011.

When a logic 0 is written to a 82C55A port pin, the $\overline{S2}/\overline{STOP}$ pin is pulled low, stopping the system clocks (CLK, CLK50, PCLK). In essence, the 82C85 is software controlled via the 82C55A. As with the $\overline{SLO}/\overline{FST}$ interface, PORT C is a logical choice for this job since the individual bit set and reset commands available for this port make control of the $\overline{S2}/\overline{STOP}$ input simple.

A START command issued to the 82C85 will override a \overline{STOP} command and the 82C85 will begin normal operation. The low state of the negative-edge triggered $\overline{S2}/\overline{STOP}$ input will not prohibit the clocks from restarting. After a START or \overline{RES} command, the 82C85 must see a passive (111) state followed by a HALT (011) state to stop the system clocks. To accomplish this, the 82C55A port output must be brought high and then returned low again for the 82C85 to recognize the next \overline{STOP} command.

External Decode Adds Halt Control

SS0, IO/\overline{M} and DT/\overline{R} can identify a MINimum mode 80C88 HALT execution. During T2 of the system timing (while ALE is high), SS0, IO/\overline{M} , and DT/\overline{R} go into a 111 state when the 80C88 is executing a software HALT. These signals cannot be tied directly to the $\overline{S2}/\overline{STOP}$, S1 and S0 inputs since they are not guaranteed to go into a passive state prior to their 111 state. These signals can be decoded during the time ALE is high to indicate a software HALT execution.

Slow Mode

When continuous operation is critical but power consumption remains a concern, the 82C85 SLOW mode operation provides a lower frequency at the CLK and CLK50 outputs (crystal/EFI frequency divided by 768). The frequency of PCLK is unaffected. The SLOW mode allows the CPU and the system to operate at a reduced rate which, in turn, reduces system power.

For example, the operating power for the 80C86 or 80C88 CPU is 10mA/MHz of clock frequency. When the SLOW mode is used in a typical 5MHz system, CLK and CLK50 run at approximately 20kHz. At this reduced frequency, the average operating current of the CPU drops to 200 μ A. Adding the 80C86/88 500 μ A standby current brings the total current to 700 μ A.

While the CPU and peripherals run slower and the 82C85 CLK and CLK50 outputs switch at a reduced frequency, the main 82C85 oscillator is still running at the maximum frequency (determined by the crystal or EFI input frequency.) Since CMOS power is directly related to operating frequency, 82C85 power supply current will typically be reduced by 15-20%.

Clock Slow/Fast Operation

The $\overline{SLO}/\overline{FST}$ input determines whether the CLK and CLK50 outputs run at full speed (crystal or EFI frequency divided by 3) or at slow speed (crystal or EFI frequency divided by 768) (See Figure 4). When in the SLOW mode, 82C85 stop-clock and stop-oscillator functions operate in the same manner as in the FAST mode.

Internal logic requires that the $\overline{SLO}/\overline{FST}$ pin be held low for at least 195 oscillator or EFI clock pulses before the SLOW mode command is recognized. This requirement eliminates unwanted FAST-to-SLOW mode frequency changes which could be caused by glitches or noise spikes.

To guarantee FAST mode recognition, the $\overline{SLO}/\overline{FST}$ pin must be held high for at least 6 OSC or EFI pulses. The 82C85 will begin FAST mode operation on the next PCLK

edge after FAST command recognition. Proper CLK and CLK 50 phase relationships are maintained and minimum pulse width specifications are met.

FAST-to-SLOW or SLOW-to-FAST mode changes will occur on the next rising or falling edge of PCLK. It is important to remember that the transition time for operating frequency changes, which are dependent upon PCLK, will vary with the 82C85 oscillator or EFI frequency.

Slow Mode Control

The 82C55A programmable peripheral interface can be used to provide control of the $\overline{\text{SLO}}/\text{FST}$ pin by connecting a port pin of the 82C55A directly to the $\overline{\text{SLO}}/\text{FST}$ pin (See Figure 1). With the port pin configured as an output, software control of the $\overline{\text{SLO}}/\text{FST}$ pin is provided by simply writing a logical one (FAST mode) or logical zero (SLOW Mode) to the corresponding port. PORT C is well-suited for this function due to its bit set and reset capabilities. Since PCLK continues to run at a frequency equal to the oscillator or EFI frequency divided by 6, it can be used by other devices in the system which need a fixed high frequency clock. For example, PCLK could be used to clock an 82C54 programmable interval timer to produce a real-time clock for the system or as a baud rate generator to maintain serial data communications during SLOW mode operation.

Oscillator

The oscillator circuit of the 82C85 is designed primarily for use with an external parallel resonant, fundamental mode crystal from which the basic operating frequency is derived. The crystal frequency should be selected at three times the required CPU clock. X1 and X2 are the two crystal input connections. The output of the oscillator is buffered and available at the OSC output (pin 18) for generation of other system timing signals.

For the most stable operation of the oscillator (OSC) output circuit, two capacitors (C1 = C2) are recommended. Capacitors C1 and C2 are chosen such that their combined capacitance matches the load capacitance as specified by the crystal manufacturer. This insures operation within the frequency tolerance specified by the crystal manufacturer.

The crystal/capacitor configuration and the formula used to determine the capacitor values are shown in Figure 4. Crystal Specifications are shown in Table 3.

$$C_T = \frac{C_1 \cdot C_2}{C_1 + C_2} \text{ (Including Stray Capacitance)} \quad (\text{EQ. 1})$$

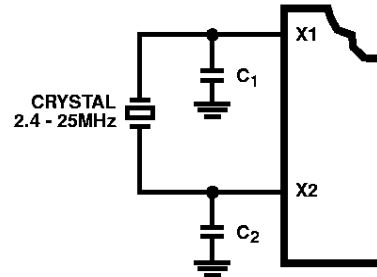

FIGURE 4. 82C85 CRYSTAL CONNECTION

TABLE 3. CRYSTAL SPECIFICATIONS

PARAMETER	TYPICAL CRYSTAL SPECIFICATION
Frequency	2.4 to 25MHz
Type of Operation	Parallel Resonant, Fund. Mode
Load Capacitance	20 or 32pF
RSERIES (Max)	35X (f = 25MHz, C _L = 32pF) 66X (f = 25MHz, C _L = 20pF)

Frequency Source Selection

The $\overline{\text{F/C}}$ input is a strapping pin that selects either the crystal oscillator or the EFI input as the source frequency for clock generation. If the EFI input is selected as the source, the oscillator section (OSC output) can be used independently for another clock source. If a crystal is not used, then crystal input X1 (pin 23) must be tied to V_{CC} or GND and X2 (pin 22) should be left open. If the EFI mode is not used, then EFI (pin 20) should be tied to V_{CC} or GND.

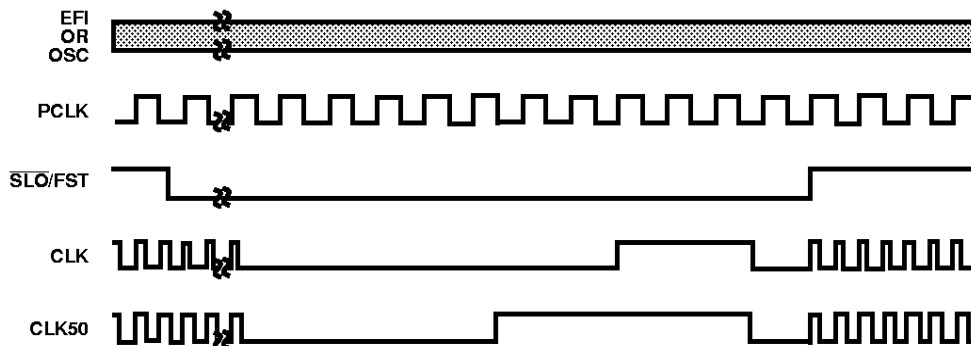

FIGURE 5. $\overline{\text{SLO}}/\text{FST}$ TIMING OVERVIEW

Clock Generator

The clock generator consists of two synchronous divide-by-three counters with special clear inputs that inhibit the counting. One counter generates a 33% duty cycle waveform (CLK) and the other generates a 50% duty cycle waveform (CLK50). These two counters are negative-edge synchronized, with the low-going transitions of both waveforms occurring on the same oscillator transition. The CLK and CLK50 output frequencies are one-third of the base input frequency when $\overline{SLO/FST}$ is high and are equal to the base input frequency divided by 768 when $\overline{SLO/FST}$ is low.

The CLK output is a 33% duty cycle clock signal designed to drive the 80C86 and 80C88 microprocessors directly. CLK50 has a 50% duty cycle output synchronous with CLK, designed to drive co-processors and peripherals requiring a 50% duty cycle clock. When $\overline{SLO/FST}$ is high, CLK and CLK50 have output frequencies which are 1/3 that of $\overline{EFI/OSC}$. When $\overline{SLO/FST}$ is low, CLK and CLK50 have output frequencies which are \overline{OSC} (EFI) divided by 768.

PCLK is a peripheral clock signal with an output frequency equal to the oscillator or EFI frequency divided by 6. PCLK has a 50% duty cycle. PCLK is unaffected by $\overline{SLO/FST}$. When the 82C85 is placed in the STOP mode, PCLK will remain in its current state (logic high or logic low) until a RESET or START command restarts the 82C85 clock circuitry. PCLK is negative-edge synchronized with CLK and CLK50.

Clock Synchronization

The clock synchronization (CSYNC) input allows the output clocks to be synchronized with an external event (such as another 82C85 or 82C84A clock signal). CSYNC going active causes all clocks (CLK, CLK50 and PCLK) to stop in the HIGH state.

It is necessary to synchronize the CSYNC input to the EFI clock external to the 82C85. This is accomplished with two flip-flops when synchronizing two 82C85s and with three flip-flops when synchronizing an 82C85 to an 82C84A (See Figure 6). Multiple external flip-flops are necessary to minimize the occurrence of metastable (or indeterminate) states.

Ready Synchronization

Two READY inputs (RDY1, RDY2) are provided to accommodate two system busses. Each READY input is qualified by $\overline{AEN1}$ and $\overline{AEN2}$, respectively). The \overline{AEN} signals validate their respective RDY signals.

Synchronization is required for all asynchronous active-going edges of either RDY input to guarantee that the RDY set up and hold times are met. Inactive-going edges of RDY in normally ready systems do not require synchronization but must satisfy RDY setup and hold as a matter of proper system design.

The \overline{ASYNC} input defines two modes of READY synchronization operation. When \overline{ASYNC} is LOW, two stages of synchronization are provided for active READY input signals. Positive-going asynchronous READY inputs will first be synchronized to flip-flop one at the rising edge of CLK (requiring a setup time TR1VCH) and then synchronized to flip-flop two at the next falling edge of CLK, after which time the READY output will go HIGH.

Negative-going asynchronous READY inputs will be synchronized directly to flip-flop two at the falling edge of CLK, after which time the READY output will go inactive. This mode of operation is intended for use by asynchronous (normally not ready) devices in the system which cannot be guaranteed by design to meet the required RDY setup timing (TR1VCL) on each bus cycle.

When \overline{ASYNC} is high or left open, the first READY flip-flop is bypassed in the READY synchronization logic. READY inputs are synchronized by flip-flop two on the falling edge of CLK before they are presented to the processor. This mode is available for synchronous devices that can be guaranteed to meet the required RDY setup time. \overline{ASYNC} can be changed on every bus cycle to select the appropriate mode of synchronization for each device in the system.

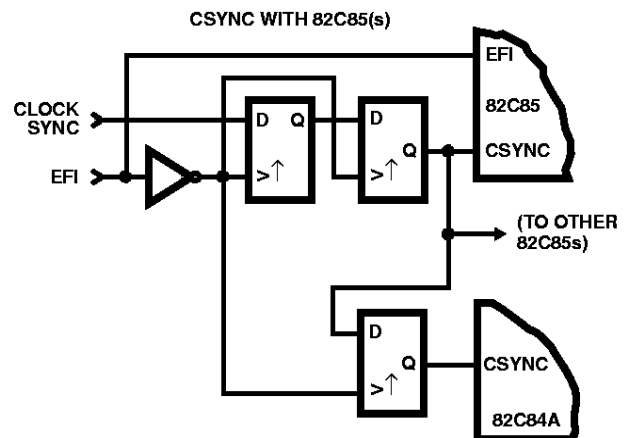

FIGURE 6. 82C85 AND 82C84A CSYNC SYNCHRONIZATION METHODS

82C85

Absolute Maximum Ratings

Supply Voltage +8.0V
 Input, Output or I/O Voltage GND -0.5V to $V_{CC} + 0.5V$
 ESD Classification Class 1

Operating Conditions

Operating Voltage Range +4.5V to +5.5V
 Operating Temperature Range
 C82C85 0°C to +70°C
 I82C85 -40°C to +85°C
 M82C85 -55°C to +125°C

Thermal Information

Thermal Resistance (Typical)	θ_{JA} (°C/W)	θ_{JC} (°C/W)
CERDIP Package	70	16
CCC Package	75	18
PLCC Package	65	N/A

Storage Temperature Range -65°C to +150°C
 Maximum Junction Temperature Ceramic Package +175°C
 Maximum Junction Temperature Plastic Package +150°C
 (Soldering 10s)
 Maximum Lead Temperature (Soldering 10s) +300°C
 (PLCC - Lead Tips Only)

Die Characteristics

Gate Count 500 Gates

CAUTION: Stresses above those listed in "Absolute Maximum Ratings" may cause permanent damage to the device. This is a stress only rating and operation of the device at these or any other conditions above those indicated in the operational sections of this specification is not implied.

DC Electrical Specifications $V_{CC} = 5.0V$ 10%; $T_A = 0^\circ C$ to +70°C (C82C85);

$T_A = -40^\circ C$ to +85°C (I82C85);

$T_A = -55^\circ C$ to +125°C (M82C85)

SYMBOL	PARAMETER	MIN	MAX	UNITS	TEST CONDITIONS
V_{IH}	Logical One Input Voltage	2.0	-	V	C82C85, I82C85 M82C85
		2.2		V	
V_{IHR}	Reset Input High Voltage	2.8	-	V	
V_{IL}	Logical Zero Input Voltage	-	0.8	V	Note 1
$V_{T+} - V_T$	Reset Input Hysteresis	0.25	-	V	
V_{OH}	Logical One Output Voltage	$V_{CC} - 0.4$	-	V	$I_{OH} = -5.0$ mA (CLK, CLK50) $I_{OH} = -1.0$ mA (X2) $I_{OH} = -2.5$ mA (all other outputs)
V_{OL}	Logical Zero Output Voltage	-	0.4	V	$I_{OL} = +2.5$ mA (X2) $I_{OL} = +5.0$ mA (all other outputs)
I_I	Input Leakage Current	-1.0	1.0	μA	$V_{IN} = V_{CC}$ or GND, except DIP Pins 11 - 15, 21, 23
I_{BHH}	Bus-hold High Leakage Current	-10	-200	μA	$V_{IN} = 3.0V$; Pins 11 - 15, 21
I_{CCSB}	Standby Power Supply Current	-	100	μA	82C85 in HALT state with oscillator stopped
I_{CCOP}	Operating Power Supply Current	-	50	mA	Crystal Frequency = 15MHz, outputs open, inputs = GND or V_{CC}
		-	70	mA	Crystal Frequency = 25MHz, outputs open, inputs = GND or V_{CC}
I_{CCSLOW}	Slow Mode Operating Current	-	40	mA Crystal Freq = 15MHz	Outputs Open; SLO/FST = GND, START = V_{CC} . Other inputs - $V_{IN} = V_{CC}$ or GND
		-	60	mA Crystal Freq = 25MHz	

NOTE:

- For CSYNC, $V_{IL} = GND$

Capacitance $T_A = 25^\circ C$

SYMBOL	PARAMETER	TYPICAL	UNITS	TEST CONDITIONS
C_{IN}	Input Capacitance	15	pF	FREQ = 1MHz, all measurements are referenced to device GND
C_{OUT}	Output Capacitance	20	pF	

82C85

AC Electrical Specifications

$V_{CC} = 5V \pm 10\%$; $T_A = 0^\circ C$ to $+70^\circ C$ (C82C85);
 $T_A = -40^\circ C$ to $+85^\circ C$ (I82C85);
 $T_A = -55^\circ C$ to $+125^\circ C$ (M82C85)

SYMBOL	PARAMETER	LIMITS		UNITS	CONDITIONS	
		MIN	MAX			
TIMING REQUIREMENTS						
(1)	TEHEL	External Frequency HIGH Time	15	-	ns	90%-90% V_{IN} , Note 1, $f = 25\text{MHz}$
(2)	TELEH	External Frequency LOW Time	15	-	ns	10%-10% V_{IN} , Note 1, $f = 25\text{MHz}$
(3)	TELEL	EFI or Crystal Period	40	-	ns	Note 1
(4)	TEFIDC	External Frequency Input Duty Cycle	45	55	%	$f = 25\text{MHz}$, Note 1
(5)	Fx	Crystal Frequency	2.4	25	MHz	Note 1
(6)	TR1VCL	RDY1, RDY2 Active Setup to CLK	35	-	ns	$\overline{\text{ASYNC}} = \text{HIGH}$
(7)	TR1VCH	RDY1, RDY2 Active Setup to CLK	35	-	ns	$\overline{\text{ASYNC}} = \text{LOW}$
(8)	TR1VCL	RDY1, RDY2 Inactive Setup to CLK	35	-	ns	
(9)	TCLR1X	RDY1, RDY2 Hold to CLK	0	-	ns	
(10)	TAYVCL	$\overline{\text{ASYNC}}$ Setup to CLK	50	-	ns	
(11)	TCLAYX	$\overline{\text{ASYNC}}$ Hold to CLK	0	-	ns	
(12)	TA1VR1V	$\overline{\text{AEN1}}$, $\overline{\text{AEN2}}$ Setup to RDY1, RDY2	15	-	ns	
(13)	TCLA1X	$\overline{\text{AEN1}}$, $\overline{\text{AEN2}}$ Hold to CLK	0	-	ns	
(14)	TYHEH	CSYNC Setup to EFI	10	-	ns	
(15)	TEHYL	CSYNC Hold to EFI	10	-	ns	
(16)	TYHYL	CSYNC Pulse Width	2TELEL	-	ns	
(17)	TI1HCL	$\overline{\text{RES}}$ Setup to CLK	65	-	ns	Note 2
(18)	TSVCH	S0, S1, $\overline{\text{S2/STOP}}$ Setup to CLK	35	-	ns	
(19)	TCHSV	S0, S1, $\overline{\text{S2/STOP}}$ Hold to CLK	35	-	ns	
(20)	TRSVCH	$\overline{\text{RES}}$, START Setup to CLK	65	-	ns	Note 2
(21)	TSHSL	$\overline{\text{RES}}$ (Low) or START (High) Pulse Width	TCLCLs3	-	ns	
(22)	TSFPC	$\overline{\text{SLO/FST}}$ Setup to PCLK	TEHEL + 100	-	ns	Note 2
(23)	TSTART	$\overline{\text{RES}}$ or START Valid to CLK Low	2TELEL + 2	-	ns	
(24)	TSTOP	$\overline{\text{STOP}}$ Command Valid to CLK High	2TCHCH + TRSVCH	3TCHCH + 34	ns	TCHCH = TCLCL
TIMING RESPONSES						
(25)	TCLCL	CLK/CLK50 Cycle Period	125	-	ns	Note 1
(26)	TCHCL	CLK HIGH Time	(1/3 TCLCL)+2	-	ns	

82C85

AC Electrical Specifications

$V_{CC} = 5V \pm 10\%$; $T_A = 0^\circ C$ to $+70^\circ C$ (C82C85);

$T_A = -40^\circ C$ to $+85^\circ C$ (I82C85);

$T_A = -55^\circ C$ to $+125^\circ C$ (M82C85) (Continued)

SYMBOL	PARAMETER	LIMITS		UNITS	CONDITIONS
		MIN	MAX		
(27) TCLCH	CLK LOW Time	(2/3 TCLCL)-15	-	ns	
(28) T5CHCL	CLK50 HIGH Time	(1/2 TCLCL)-7.5	-	ns	
(29) T5CLCH	CLK50 LOW Time	(1/2 TCLCL)-7.5	-	ns	
(30) TCH1CH2	CLK/CLK50 Rise Time	-	8	ns	1.0V to 3.5V
(31) TCL2CL1	CLK/CLK50 Fall Time	-	8	ns	1.0V to 3.5V
(32) TPHPL	PCLK HIGH Time	TCLCL-20	-	ns	
(33) TPLPH	PCLK LOW Time	TCLCL-20	-	ns	
(34) TRYLCL	Ready Inactive to CLK	-8	-	ns	Note 4
(35) TRYHCH	Ready Active to CLK	2/3(TCLCL)-15	-	ns	Note 3
(36) TCLIL	CLK to Reset Delay	-	40	ns	
(37) TCLPH	CLK to PCLK HIGH Delay	-	22	ns	
(38) TCLPL	CLK to PCLK LOW Delay	-	22	ns	
(39) TOST	Start/Reset Valid to Clock LOW	-	2	ms	Typ. - Note 8
(40) TOLOH	Output Rise Time (except CLK)	-	15	ns	From 0.8V to 2.0V
(41) TOHOL	Output Fall Time (except CLK)	-	12	ns	From 2.0V to 0.8V
(42) TRST	RESET output HIGH Time	16 x TCLCL	-	ns	
(43) TCLC50L	CLK LOW to CLK50 LOW Skew	-	5	ns	

NOTES:

1. Slow and Fast Modes.
2. Setup and hold necessary only to guarantee recognition at next clock.
3. Applies only to T3, TW states.
4. Applies only to T2 states.
5. All timing delays are measured at 1.5V unless otherwise noted.
6. Input signals must switch between V_{IL} max - 0.4 and V_{IH} min + 0.4 volts
7. Timing measurements made with EFI duty cycle = 50%.
8. Oscillator start up time depends on several factors including crystal frequency, crystal manufacturer, capacitive load, temperature, power supply voltage, etc. This parameter is given for information only.
9. Output signals switch between V_{OH} and V_{OL} unless otherwise specified.

Timing Waveforms (Continued)

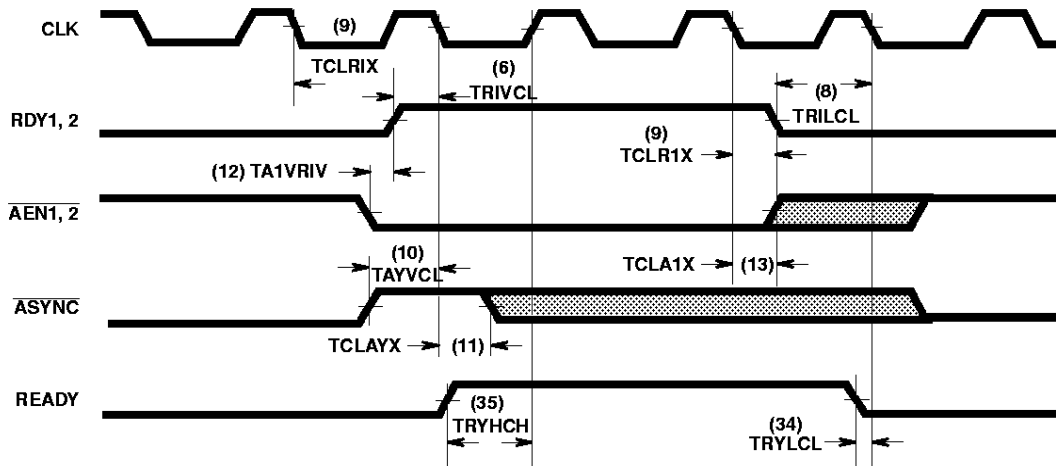

FIGURE 9. WAVEFORMS FOR READY SIGNALS (FOR SYNCHRONOUS DEVICES)

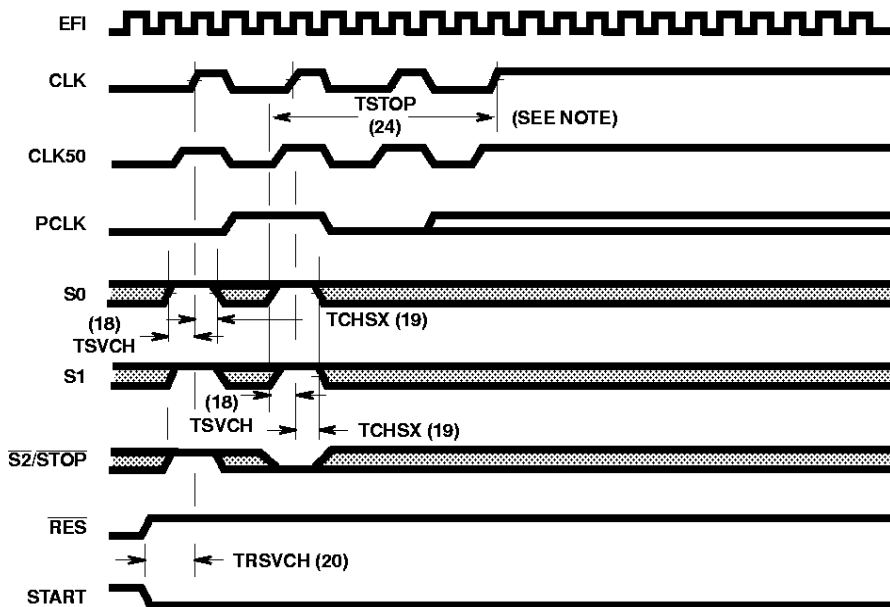

FIGURE 10. CLOCK STOP (F/\bar{C} HIGH OR F/\bar{C} LOW)

NOTE: When F/\bar{C} is low, CLK and CLK50 stop high. When F/\bar{C} is high, CLK and CLK50 may stop either high or low.

Timing Waveforms (Continued)

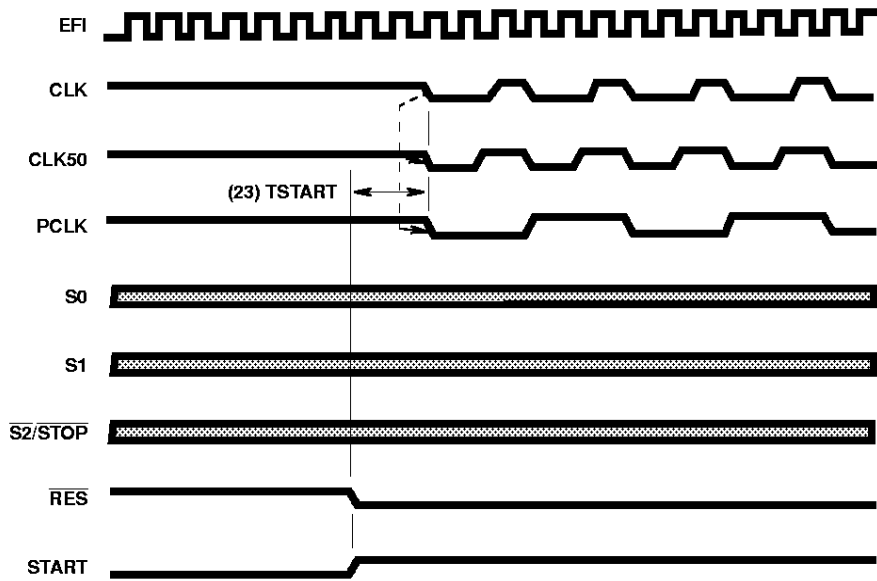

FIGURE 11. CLOCKS START (F/\bar{C} HIGH)

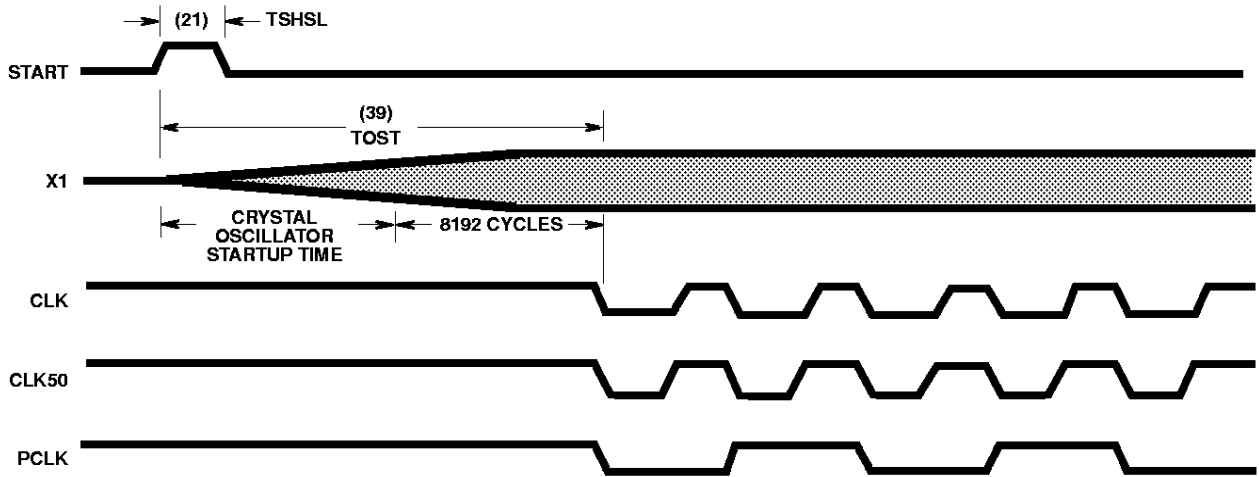

FIGURE 12. CLOCK START (F/\bar{C} LOW)

NOTE: Start up count begins when the crystal oscillator reaches a suitable threshold level.

Timing Waveforms (Continued)

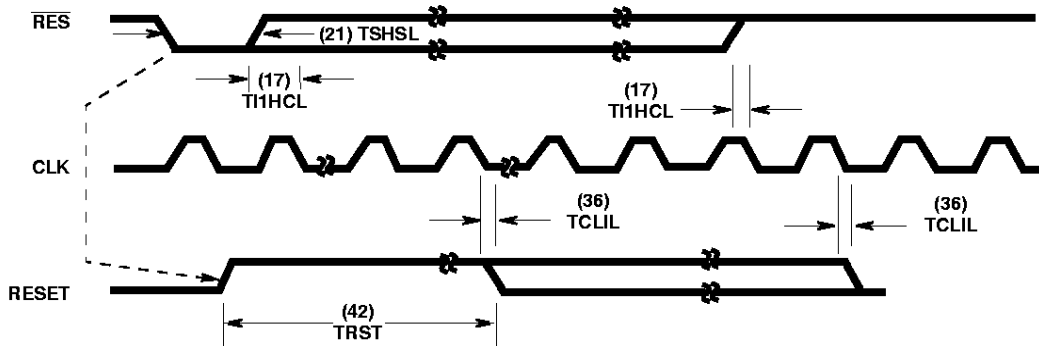

FIGURE 13. RESET TIMING (CLK RUNNING WITH F/C LOW-OSC MODE)
(CLK RUNNING-OR STOPPED WITH F/C HIGH EFI MODE)

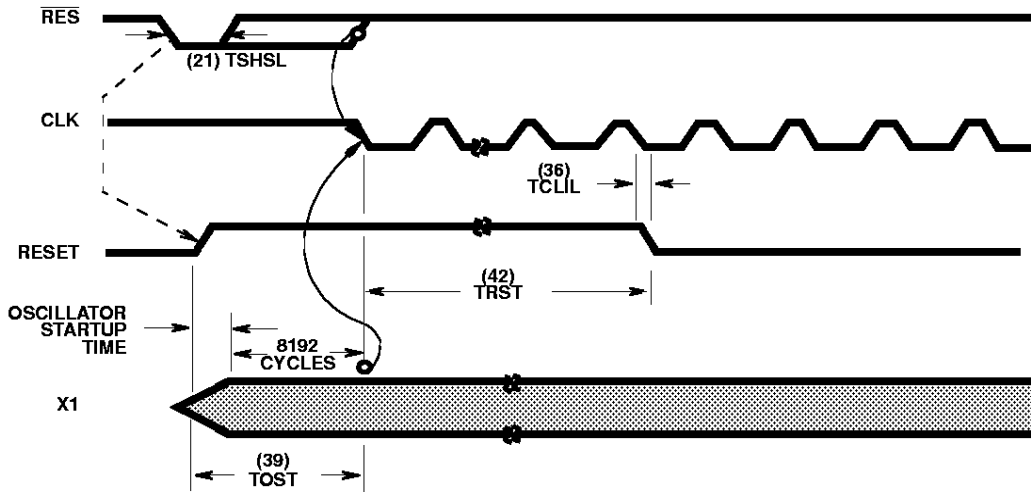

FIGURE 14. RESET TIMING (OSCILLATOR STOPPED, F/C LOW)

NOTE: CLK, CLK50, PCLK Remain in the High State until \overline{RES} goes high and 8192 valid oscillator cycles have been registered by the 82C85 internal counter (TOST time period). After \overline{RES} goes high and CLK, CLK50, PCLK become active, the RESET output will remain high for minimum of 16 CLK cycles (TRST).

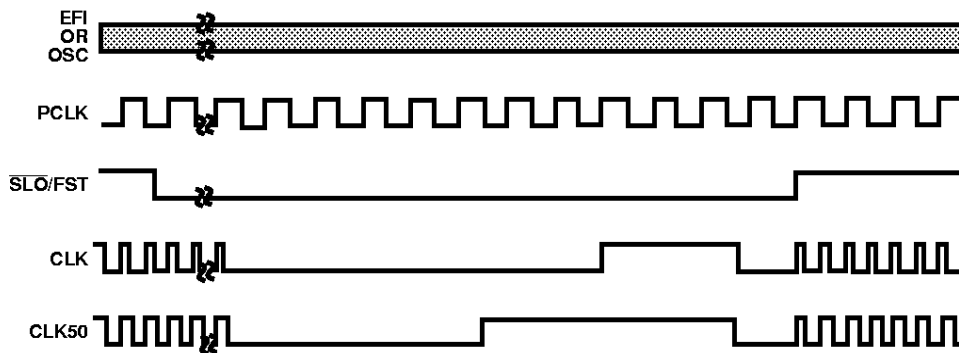

FIGURE 15. SLO/FST TIMING OVERVIEW

NOTE: See Fast to Slow Clock Mode Transition for Detailed Timing; See Slow to Fast Clock Mode Transition for Detailed Timing

Timing Waveforms (Continued)

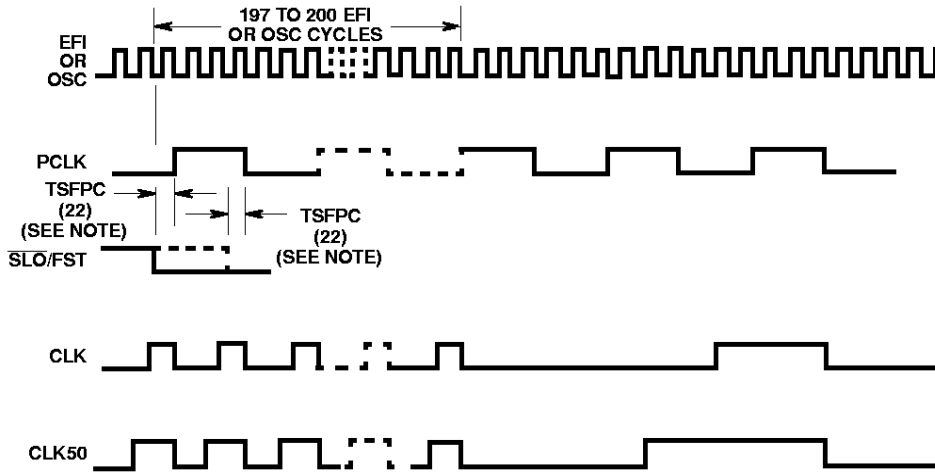

FIGURE 16. FAST TO SLOW CLOCK MODE TRANSITION

NOTE: IF TSFPC is not met on one edge of PLCK. SLO/FST will be recognized on the next edge of PLCK.

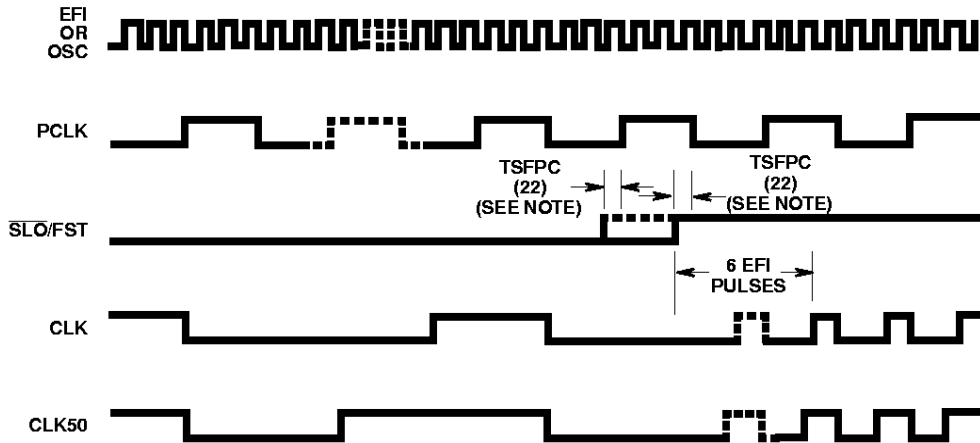
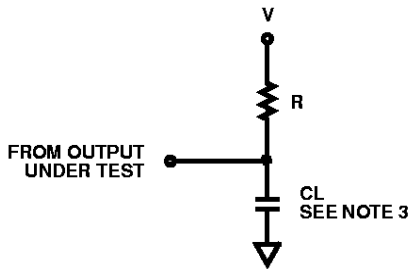

FIGURE 17. SLOW TO FAST CLOCK MODE TRANSITION

NOTE: IF TSFPC is not met on one edge of PLCK. SLO/FST will be recognized on the next edge of PLCK.

Test Load Circuits

PASSIVE LOAD



DYNAMIC LOAD

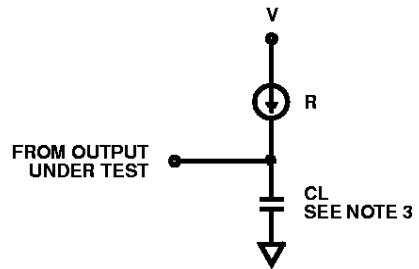

R = 360 at V = 2.25 for CLK and CLK50 outputs
 R = 470 at V = 2.87 for all other outputs (Except X2)

$I_{OL} = 5\text{mA}$, $I_{OH} = -5\text{mA}$ for CLK and CLK50 outputs
 $I_{OL} = 5\text{mA}$, $I_{OH} = -2.5\text{mA}$ for all other outputs (Except X2)
 $I_{OL} = 2.5\text{mA}$, $I_{OH} = -1.0\text{mA}$ for X2 output (DC Performance characteristic only)
 $V_{TRIP} = 1.4\text{V}$

NOTES:

1. $C_L = 100\text{pF}$ for CLK and CLK50 output
2. $C_L = 50\text{pF}$ minimum for all other outputs
3. $C_L =$ Includes probe and jig capacitance

TCHCL, TCLCH LOAD CIRCUIT (USING X1, X2)

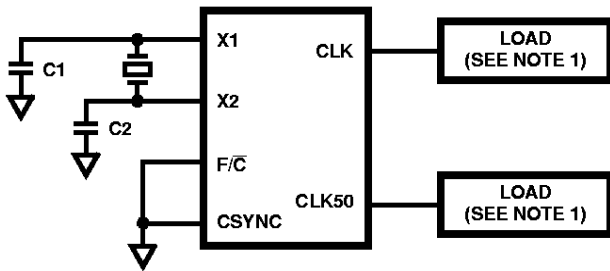

TCHCL, TCLCH LOAD CIRCUIT (USING EFI)

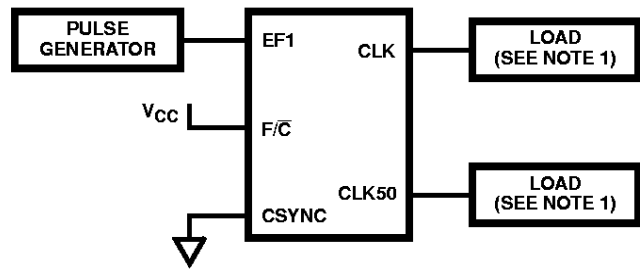

TRYLCL, TRYHCH LOAD CIRCUIT (USING X1, X2)

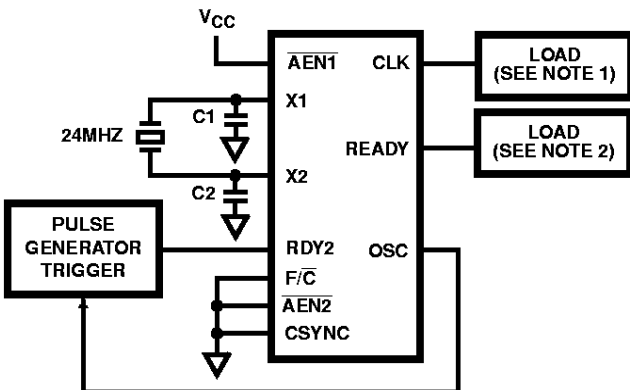

TRYLCL, TRYHCH LOAD CIRCUIT (USING EFI)

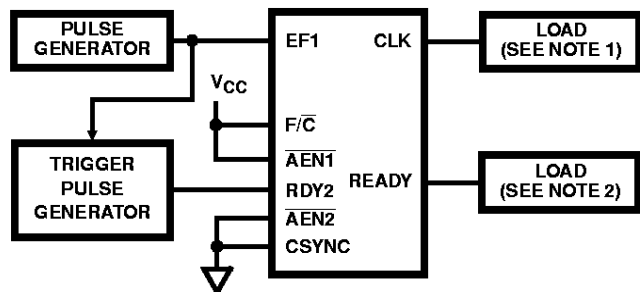

A.C. Testing Input, Output Waveform

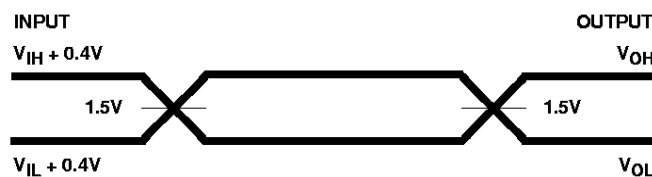

82C85

Die Characteristics

DIE DIMENSIONS:
107.9 x 122.0 x 19 ± 1mil

METALLIZATION:
Type: Si - AL
Thickness: 11kÅ ± 1kÅ

GLASSIVATION:
Type: SiO₂
Thickness: 8kÅ ± 1kÅ

WORST CASE CURRENT DENSITY:
2.26x 10⁵ A/cm²
This device meets glassivation integrity test requirements per MIL-STD-883 Method 2021

Metallization Mask Layout

