

PART NUMBER	SSL-LX5063SRD	REV	D
REV	E.C.N. NUMBER AND REVISION COMMENTS	DATE	
A	UPDATED SPECS	07.17.95	
B	E.C.N.#10BRDR. & REDRAWN IN 3D	05.08.01	
C	E.C.N.#11148	10.31.06	
D	ECN-Lumex202300080	08.03.23	

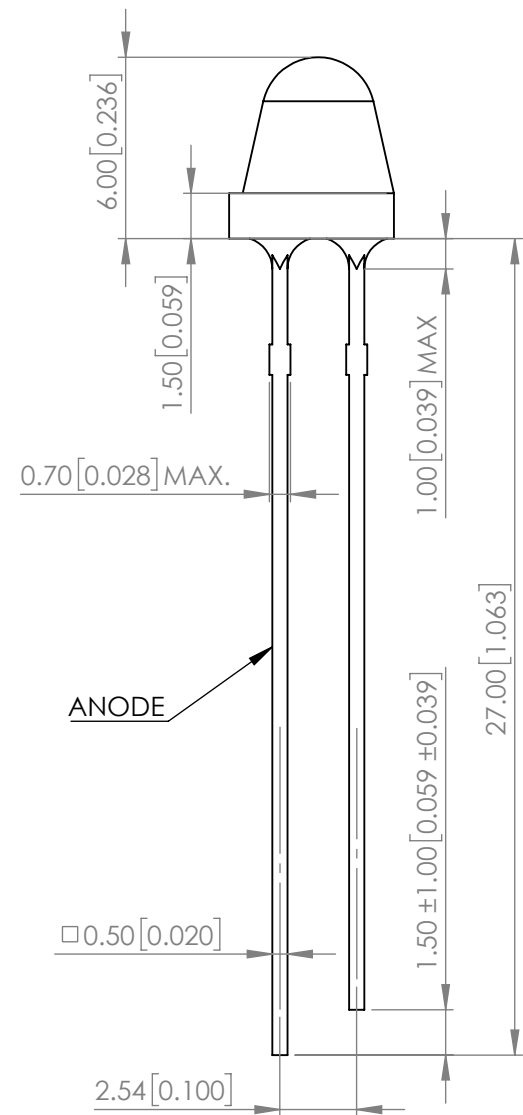

POLARITY

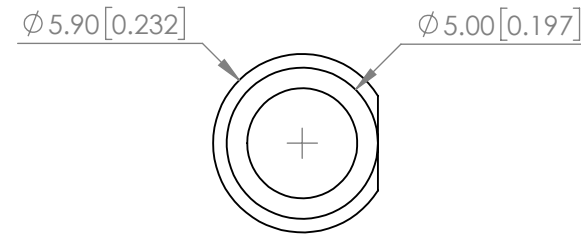
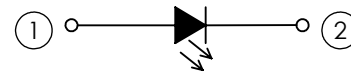

ELECTRO-OPTICAL CHARACTERISTIC TA=25°C

PARAMETER	MIN	TYP	MAX	UNITS	TEST COND
PEAK WAVELENGTH*	-	645	-	nm	If=20mA
FORWARD VOLTAGE	-	1.9	2.5	Vf	If=20mA
REVERSE CURRENT	-	-	10	uA	VR=5V
LUMINOUS INTENSITY	-	180	-	mcd	If=20mA
VIEWING ANGLE	-	60	-	2x theta1/2	If=20mA
EMITTED COLOR	RED				
EPOXY LENS FINISH	RED DIFFUSED				

ABSOLUTE MAXIMUM RATINGS TA=25°C

PARAMETER	MAX	UNITS
PEAK FORWARD CURRENT*	150	mA
FORWARD CURRENT	30	mA
REVERSE VOLTAGE	5	V
POWER DISSIPATION	75	mW
STORAGE TEMPERATURE	-40 TO +85	°C
OPERATING TEMPERATURE	-40 TO +85	°C
SOLDERING TEMPERATURE**	3 SEC. MAX. @260	°C

*1/10 DUTY CYCLE, 0.1ms PULSE WIDTH
 **2.0mm FROM BODY

STATIC DEVICE FOLLOW PROPER
 E.S.D. HANDLING PROCEDURES
 WHEN WORKING WITH THIS PART

*UNLESS OTHERWISE SPECIFIED TOLERANCES PER DECIMAL PRECISION ARE: X=±1 (±0.039), X.X=±0.5 (±0.020), X.XX=±0.25 (±0.010), X.XXX=±0.127 (±0.005). LEAD SIZE=±0.05 (±0.002), LEAD LENGTH=±0.75 (±0.030). MIN= ^{+DECIMAL PRECISION}/_{-0.00} MAX.= ^{+0.00}/_{-DECIMAL PRECISION}