

THIS DRAWING IS UNPUBLISHED. RELEASED FOR PUBLICATION
 © COPYRIGHT - By - ALL RIGHTS RESERVED.

LOC	DIST	REVISIONS					
HC	00	P	LTR	DESCRIPTION	DATE	DWN	APVD
		C		REV PER ECO-15-000041	2/9/2015	RZ	MC

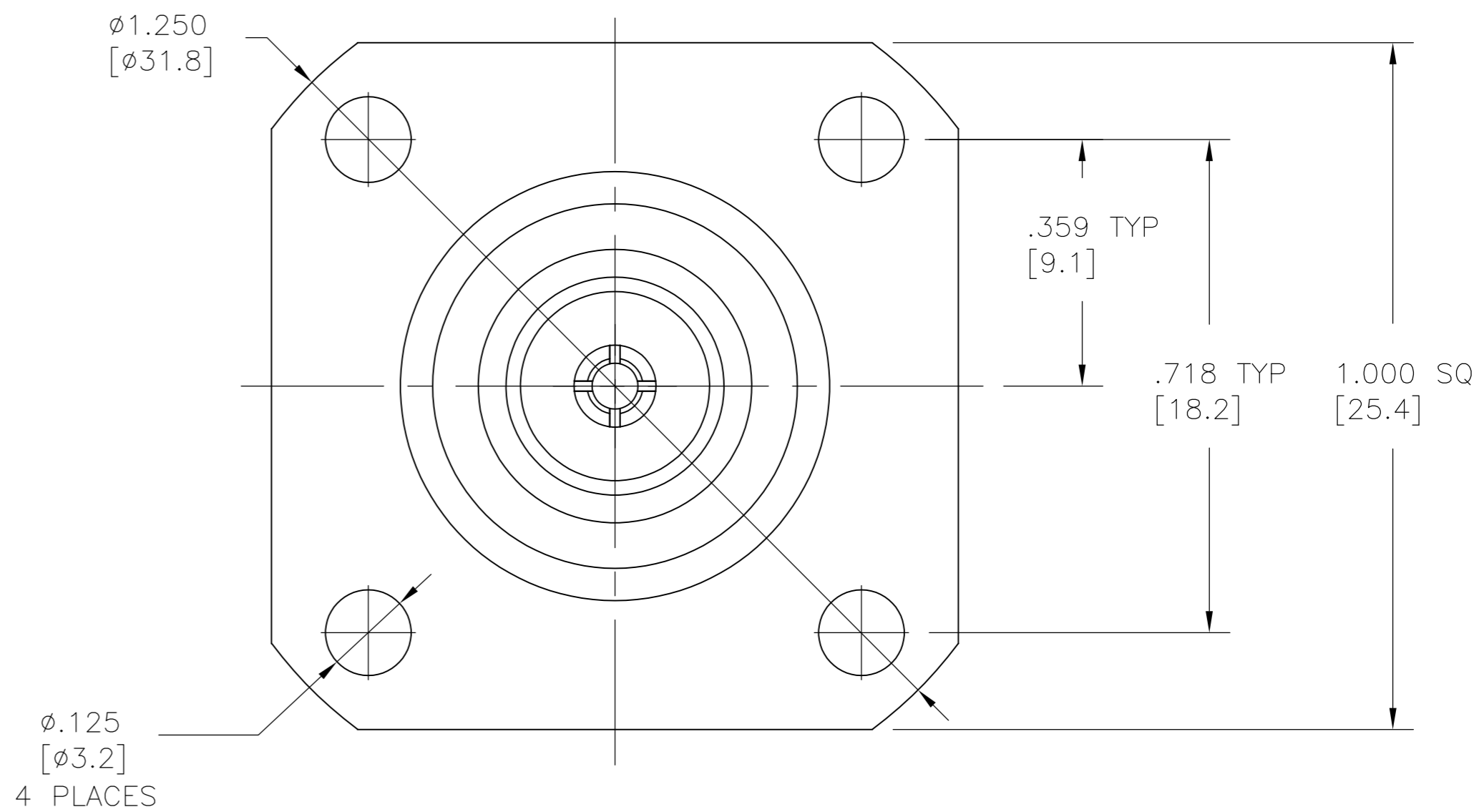
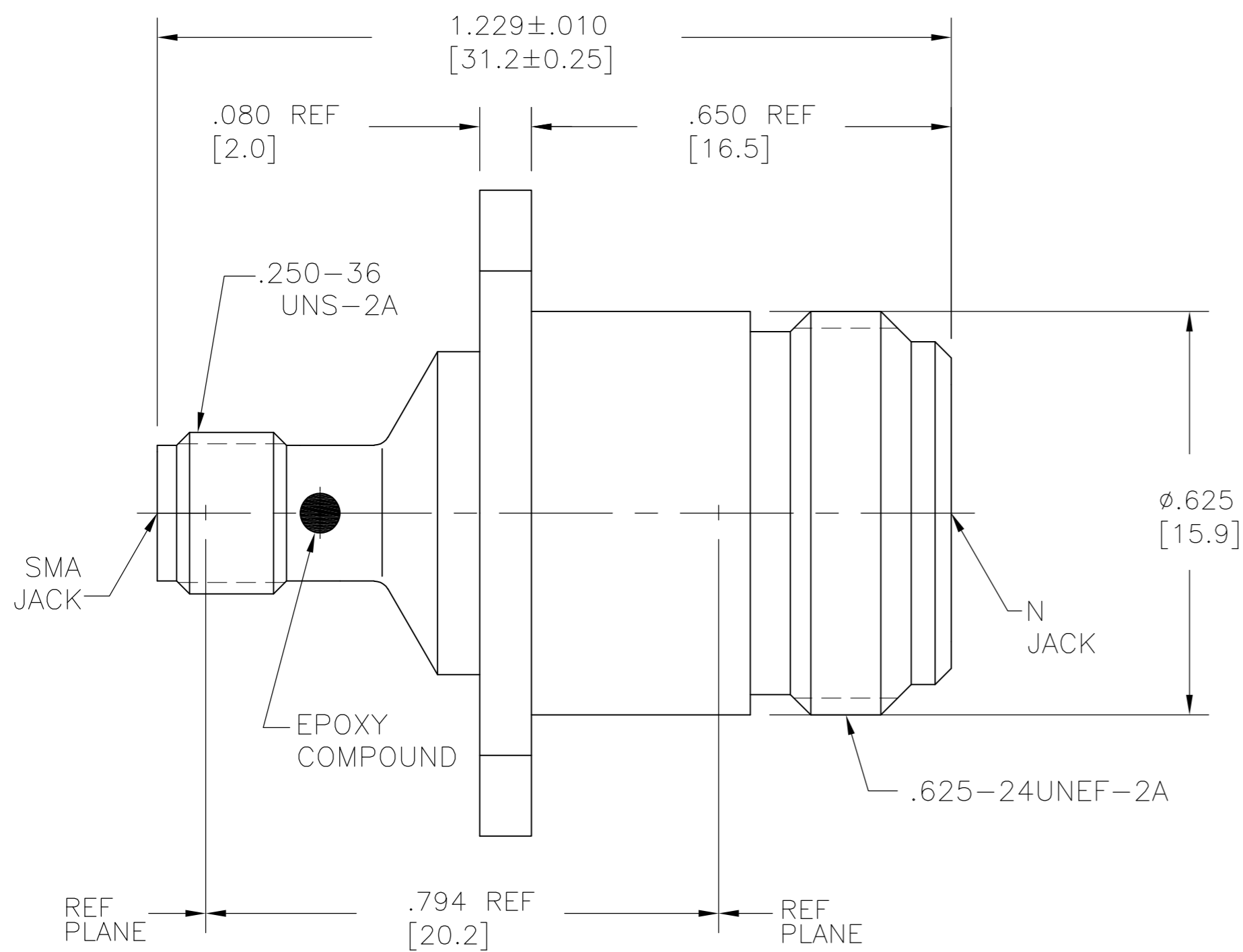

ELECTRICAL	MECHANICAL	ENVIRONMENTAL
Nominal Impedance (Ohms) <u>50</u>	Interface Dimensions MIL-STD-348A, Fig. 310.2 (SMA) AND 304.2 (N)	Temperature Rating <u>-65°C TO +125°C</u>
Frequency Range (GHz) <u>DC to 18</u>	Recommended Mating Torque <u>N/A</u>	Vibration MIL-STD-202, Method 204, Condition B
Volt Rating (VRMS MAX) @ Sea Level <u>335</u>	Mating Characteristics: SMA-Insertion (MAX Lbs) <u>3.0</u>	Shock MIL-STD-202, Method 213, Condition I
VSWR <u>DC-12.4GHz: 1.06+.005f(GHz) MAX</u> <u>12.4-18.0GHz: .83+.023f(GHz) MAX</u>	N-Insertion (MAX Lbs) <u>2.0</u>	Thermal Shock MIL-STD-202, Method 107, Condition C, Except high temp shall be +115°C
Insertion Loss (dB MAX) <u>.18 @ 9GHz</u>	SMA-Withdrawal (MIN Oz) <u>1.0</u>	Moisture Resistance MIL-STD-202, Method 106
RF Leakage (dB MIN) <u>-65 @ 2-3 GHz</u>	N-Withdrawal (MIN Oz) <u>2.0</u>	Corrosion - MIL-STD-202, Method 101, Condition B, 5% salt spray
Corona, 70,000 Ft (VRMS MIN) <u>250</u>	Force to Engage and Disengage SMA (In-Lbs MAX) <u>2.0</u>	
Dielectric Withstanding Voltage (VRMS MIN) @ Sea Level <u>1000</u>	N (In-Lbs MAX) <u>6.0</u>	
Contact Resistance (Milliohms MAX) Center Contact <u>4.1</u>	Center Contact Captivation Axial (Lbs) <u>6.0</u>	
Outer Contact <u>2.2</u>	Radial (In-Oz) <u>4.0</u>	
Cable to Housing <u>N/A</u>	Cable Retention Axial Force (Lbs) <u>N/A</u>	
RF High Potential @ Sea Level (VRMS MIN @ 5 MHz) <u>1000</u>	Torque (In-Oz) <u>N/A</u>	
I.R.(Megohms MIN) <u>5,000</u>	Weight (Grams) <u>TBD</u>	

FINISH	MATERIAL	COMPONENT
PASSIVATED	STAINLESS STEEL PER ASTM-A484 AND ASTM-A582. TYPE 303	HOUSING
N/A	PTFE PER ASTM-D-1457	DIELECTRIC
GOLD PLATE PER MIL-G-45204 OVER NICKEL PLATE PER QQ-N-290	BERYLLIUM COPPER PER ASTM B 196. ALLOY C17300. CONDITION H	CENTER CONTACT

THIS DRAWING IS A CONTROLLED DOCUMENT.		DWN CD 2-10-83	 TE Connectivity
DIMENSIONS: INCHES		CHK WK 2-23-83	
TOLERANCES UNLESS OTHERWISE SPECIFIED:		APVD DRG 3-3-83	
0 PLC ± - 1 PLC ± - 2 PLC ± - 3 PLC ± .005 4 PLC ± - ANGLES ± 1°		PRODUCT SPEC -	
MATERIAL -	FINISH -	APPLICATION SPEC -	NAME SMA JACK TO N JACK ADAPTOR (3680-2242-00)
		WEIGHT -	SIZE A2 CAGE CODE 00779 DRAWING NO C=1058653-1
		CUSTOMER DRAWING	RESTRICTED TO -
		SCALE 5:1	SHEET 1 of 1 REV C