

THIS DRAWING IS UNPUBLISHED. RELEASED FOR PUBLICATION
 © COPYRIGHT BY TYCO ELECTRONICS CORPORATION. ALL RIGHTS RESERVED.

LOC		DIST		REVISIONS					
AJ		00		P	LTR	DESCRIPTION	DATE	DWN	APVD
				C		REV PER ECO 08-026436	2DEC2008	DW	JL

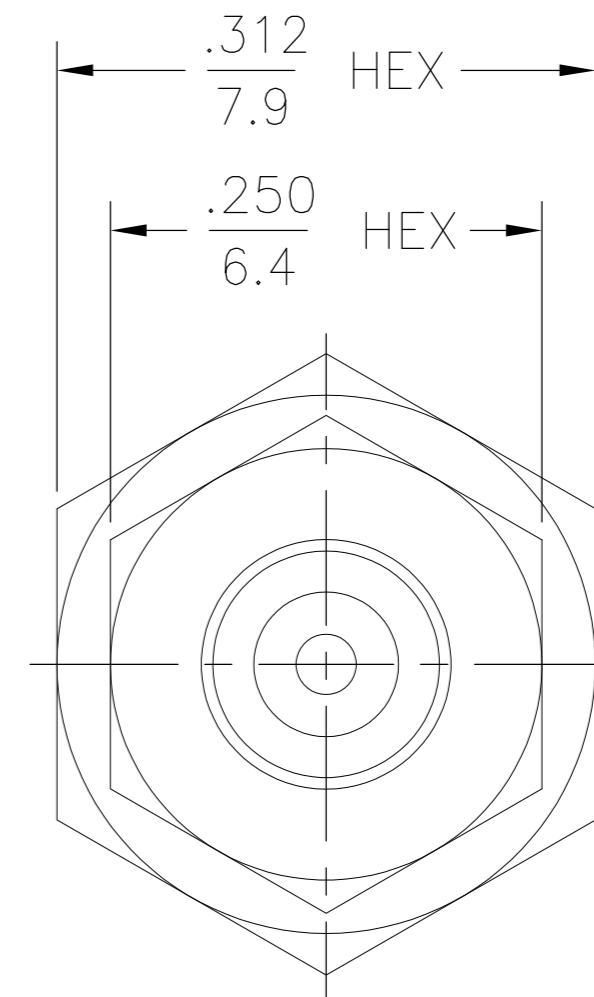
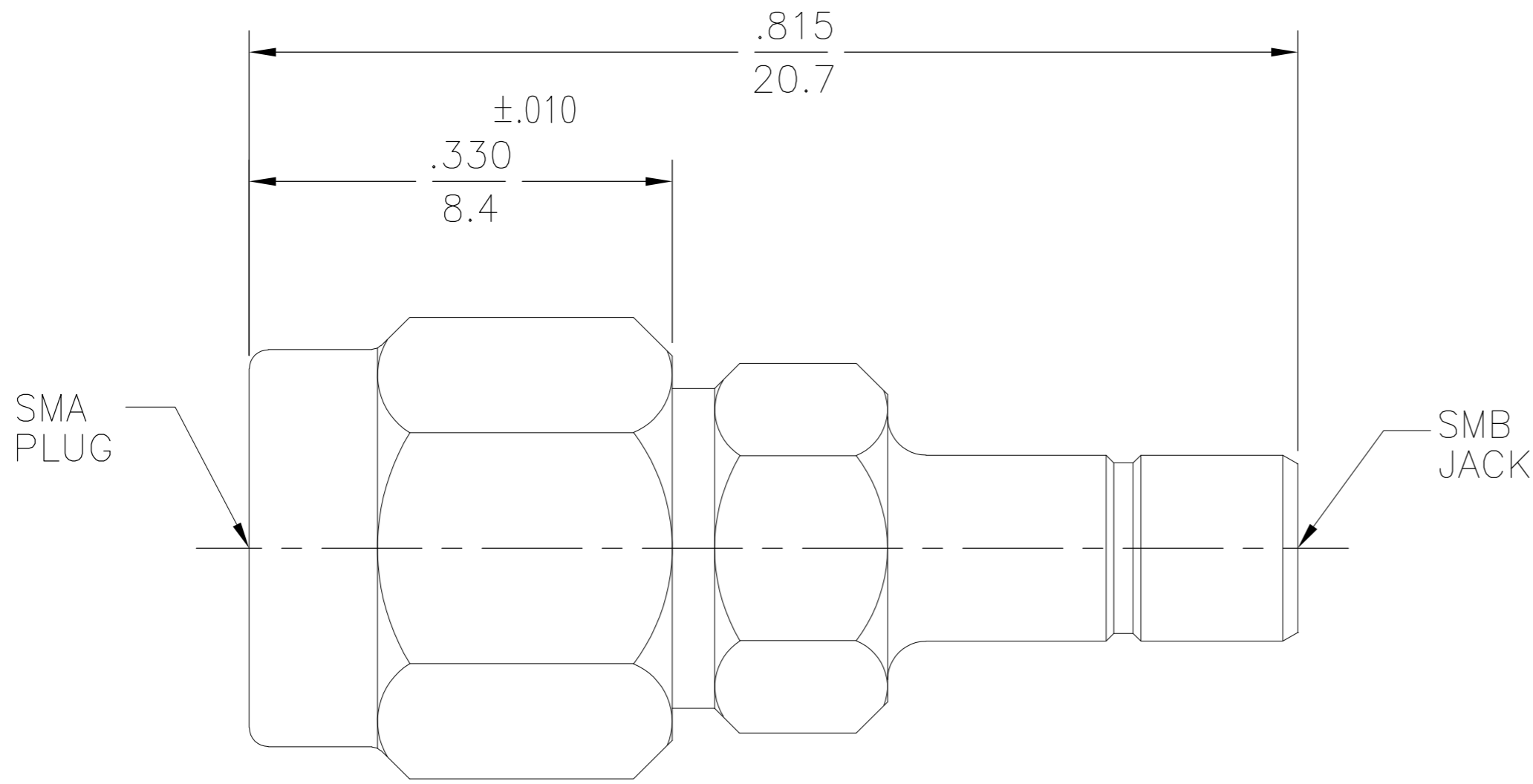

ELECTRICAL	MECHANICAL	ENVIRONMENTAL
Nominal Impedance (Ohms) <u>50</u>	Interface Dimensions	TEMPERATURE RATING <u>-65°C TO +125°C</u>
Frequency Range (GHz) DC to <u>4.0</u>	<u>SMB MIL-STD-348A 311-1</u>	Vibration MIL-STD-202, Method
Volt Rating (VRMS MAX)	<u>OSM MIL-STD-348A 310-1</u>	204, Condition B
@ Sea Level <u>.335</u>	Recommended Mating Torque	Shock MIL-STD-202, Method 213,
VSWR <u>1.25+.04f(GHz)</u>	<u>7-10 In-Lbs</u>	Condition B
Insertion Loss (dB MAX) <u>.03 @ 1.5GHz</u>	Mating Characteristics:	Thermal Shock MIL-STD-202,
RF Leakage (dB MIN) <u>-55 @ 2 to 3 GHz</u>	<u>SMB</u> <u>OSM</u>	Method 107, Condition B,
Corona, 70,000 Ft (VRMS MIN) <u>250</u>	Insertion <u>2.5</u> <u>3.0</u>	EXCEPT HIGH TEMP +85°C
Dielectric Withstanding Voltage	Withdrawal <u>1.0</u> <u>2.0</u>	Moisture Resistance MIL-STD-202,
(VRMS MIN) @ Sea Level <u>1,000</u>	Force to Engage/Disengage (Lbs)	Method 106 Shall Be Omitted
Contact Resistance (Milliohms MAX)	<u>SMB</u> <u>14.0</u>	Corrosion - MIL-STD-202, Method
Center Contact <u>6.0</u>	<u>OSM</u> <u>2.0</u>	101, Condition B, 5% salt spray
Outer Contact <u>1.0</u>	Contact Retention	
RF High Potential @ Sea Level	Axial (Lbs) <u>6.0</u>	
(VRMS MIN @ 5 MHz) <u>700</u>	Radial (In-Oz) <u>4.0</u>	
I.R.(Megohms MIN) <u>1,000</u>	Weight (Grams) <u>TBD</u>	

.XXX = in
 XX.X = mm (REF)

1060500-1
 PART NUMBER

COMPONENT	MATERIAL	FINISH
HOUSING COUPLING NUT	STAINLESS STEEL PER ASTM-A484 AND ASTM-A582, TYPE 303	PASSIVATE PER QQ-P-35
DIELECTRIC	PTFE FLUOROCARBON PER ASTM-D-1457	N/A
CENTER CONTACT	BRASS PER ASTM-B-16	GOLD PLATE PER MIL-G-45204
RETAINING RING	BERYLLIUM COPPER PER ASTM-B-194, ALLOY C17200, CONDITION H	N/A
GASKET	SILICONE RUBBER PER ZZ-R-765	N/A

THIS DRAWING IS A CONTROLLED DOCUMENT.		DWN RBG 8/3/77	Tyco Electronics Corporation Harrisburg, PA 17105-3608	
DIMENSIONS: INCHES		CHK KWW 8/3/77	NAME SMA PLUG TO SMB JACK ADAPTER	
TOLERANCES UNLESS OTHERWISE SPECIFIED:		APVD RMF 8/3/77	SIZE CAGE CODE DRAWING NO RESTRICTED TO	
0 PLC ± -	1 PLC ± -	PRODUCT SPEC	A2 00779 C=1060500-1	
2 PLC ± -	3 PLC ± .005	APPLICATION SPEC	SCALE 8:1 SHEET 1 of 1 REV C	
4 PLC ± -	ANGLES ± 1°	WEIGHT -		
MATERIAL -	FINISH -	CUSTOMER DRAWING		