

HC-STA-B48-HHFS-BLANK-EM-AL - Housing



1326510

<https://www.phoenixcontact.com/us/products/1326510>

Please be informed that the data shown in this PDF document is generated from our online catalog. Please find the complete data in the user documentation. Our general terms of use for downloads are valid.



Sleeve housing B48, for single locking latch, material: Die-cast aluminum, salt water resistant, variable, height: 107.5 mm, cable gland: none, Standard

Your advantages

- Good shielding in the event of electromagnetic interference

Commercial data

Item number	1326510
Packing unit	1 pc
Minimum order quantity	1 pc
Sales key	BF56
Product key	BF7APB
GTIN	4063151617424
Weight per piece (including packing)	609.8 g
Weight per piece (excluding packing)	609.8 g
Customs tariff number	85389099
Country of origin	CN

HC-STA-B48-HHFS-BLANK-EM-AL - Housing



1326510

<https://www.phoenixcontact.com/us/products/1326510>

Technical data

Product properties

Type	B48
Product type	Housing with locking latch
Application	Standard
Housing type	Sleeve housing
Cable outlet	variable
Pg screw connection	none

Dimensions

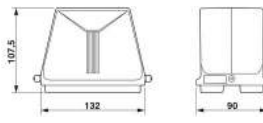
Dimensional drawing	
Width	90 mm
Height	107.5 mm
Length	132 mm

Material specifications

Housing surface material	uncoated
Impact strength	IK08
Housing material	Die-cast aluminum, salt water resistant

Mechanical properties

Mechanical data

Locking type	Pin
--------------	-----

Environmental and real-life conditions

Ambient conditions

Degree of protection	IP66
	IP67
Degree of protection (NEMA)	4 (UL 50e)
	4X (UL 50e)
	12 (UL 50e)
Impact strength	IK08

HC-STA-B48-HHFS-BLANK-EM-AL - Housing

1326510

<https://www.phoenixcontact.com/us/products/1326510>



Drawings

Dimensional drawing

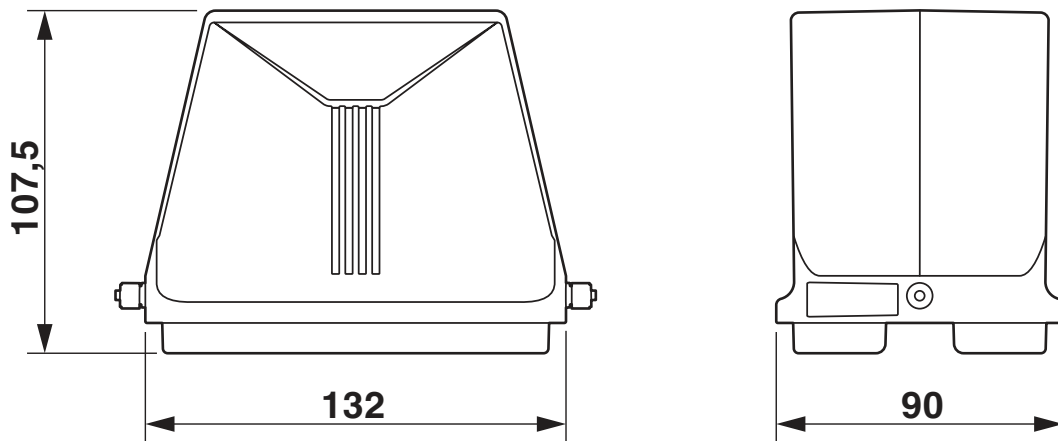

Dimensional drawing

HC-STA-B48-HHFS-BLANK-EM-AL - Housing



1326510

<https://www.phoenixcontact.com/us/products/1326510>

Approvals

To download certificates, visit the product detail page: <https://www.phoenixcontact.com/us/products/1326510>



cUL Recognized
Approval ID: E255026



UL Recognized
Approval ID: E255026

cULus Recognized

HC-STA-B48-HHFS-BLANK-EM-AL - Housing



1326510

<https://www.phoenixcontact.com/us/products/1326510>

Classifications

ECLASS

ECLASS-11.0	27440202
ECLASS-12.0	27440202
ECLASS-13.0	27440202

ETIM

ETIM 8.0	EC000437
----------	----------

UNSPSC

UNSPSC 21.0	31261500
-------------	----------

HC-STA-B48-HHFS-BLANK-EM-AL - Housing



1326510

<https://www.phoenixcontact.com/us/products/1326510>

Environmental product compliance

China RoHS	Environmentally friendly use period: unlimited = EFUP-e
	No hazardous substances above threshold values

HC-STA-B48-HHFS-BLANK-EM-AL - Housing



1326510

<https://www.phoenixcontact.com/us/products/1326510>

Accessories

US-EMLP (20X9) CUS - Plastic label

0830085

<https://www.phoenixcontact.com/us/products/0830085>

Plastic label, can be ordered: by card, white, labeled according to customer specifications, mounting type: adhesive, lettering field size: 20 x 9 mm, Number of individual labels: 75



US-EMLP-HA (20X9) - Plastic label

0830989

<https://www.phoenixcontact.com/us/products/0830989>

Plastic label, Card, white, unlabeled, can be labeled with: BLUEMARK ID COLOR, BLUEMARK ID, THERMOMARK PRIME, THERMOMARK CARD 2.0, THERMOMARK CARD, mounting type: adhesive, lettering field size: 20 x 9 mm, Number of individual labels: 70



Phoenix Contact 2023 © - all rights reserved

<https://www.phoenixcontact.com>

Phoenix Contact USA

586 Fulling Mill Road

Middletown, PA 17057, United States

(+717) 944-1300

info@phoenixcon.com