

PART NUMBER	LEAD FREE VERSION
7361E0225S16	7361E0225S16LF

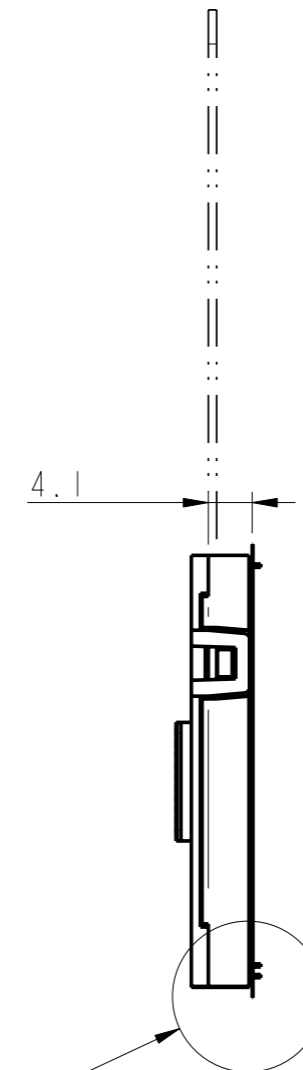
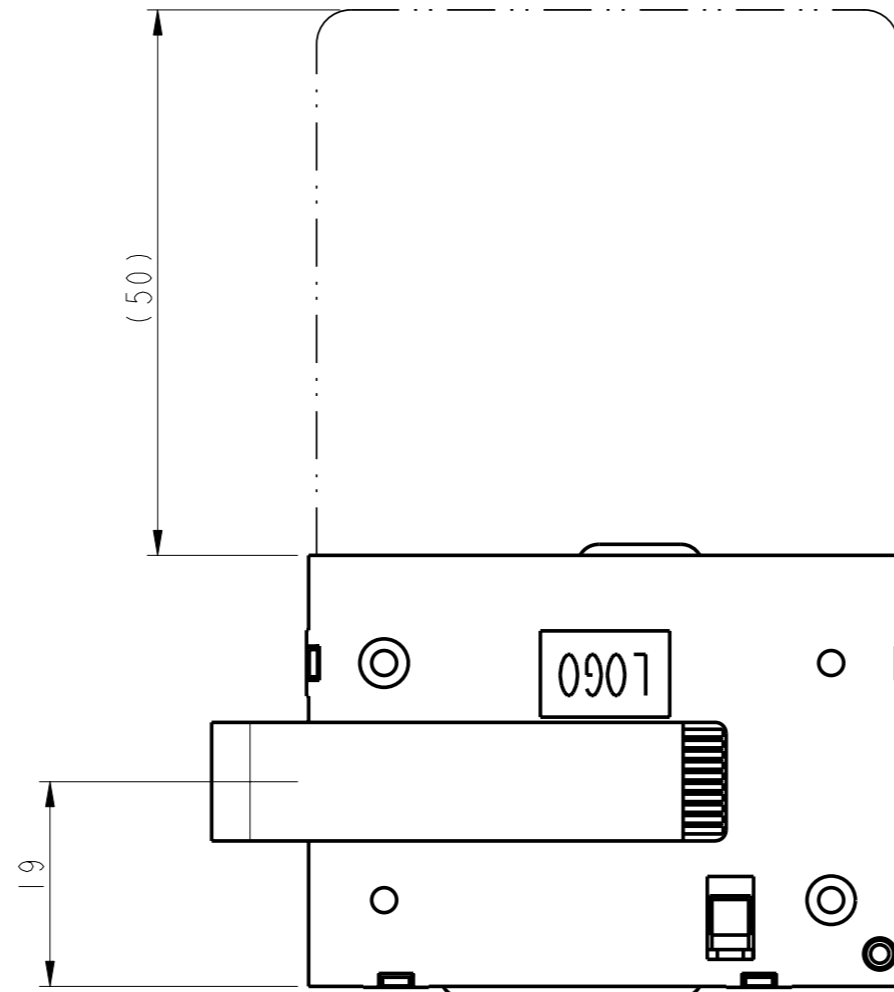
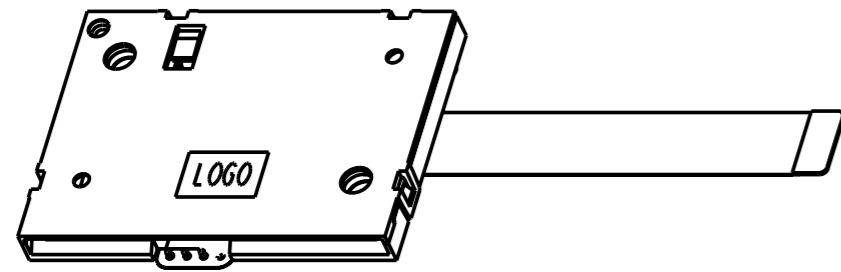

**GENERAL :**  
 High cycle life duration smart card connector with landing type contacts mechanism. The landing type connector also provides the feature of recessed contacts when card is not inserted which protects them against vandalism.  
 Smart card for reference purposes only.

**ELECTRICAL PROPERTIES:**  
 Insulation resistance : > 1000MΩ  
 Dielectric withstanding voltage : >750 Vrms  
 Current carrying capacity : Min 10μA, Max 1A  
 Contact resistance : < 100mΩ

**MECHANICAL PROPERTIES :**  
 Operating force : Insertion : F < 10N  
 Withdrawal : 1 < F < 10N  
 Contact Normal force : 0.2 < F < 0.3 for 0.6mm of deflection  
 Durability : 200 000 mating cycles

**MATERIAL :**  
 Head reader : High temp. Thermoplastic, Colour Black, Rated UL94V0  
 Cover : High temp. Thermoplastic, Colour Grey, Rated UL94V0  
 Contacts : Copper alloy,  
 Plating : 2.5μm Nickel min. all over  
 2μm Gold min. on contact area  
 3μm SnPb(60/40) min. on solder tails(for leaded version)  
 3μm matte tin min. on solder tails(for lead free version)

**ENVIRONMENT :**  
 Operating temperature : -40°C / +90°C  
 Climatic conditions : UTE 93-421

**PACKAGING :**  
 Plastic cavity tray

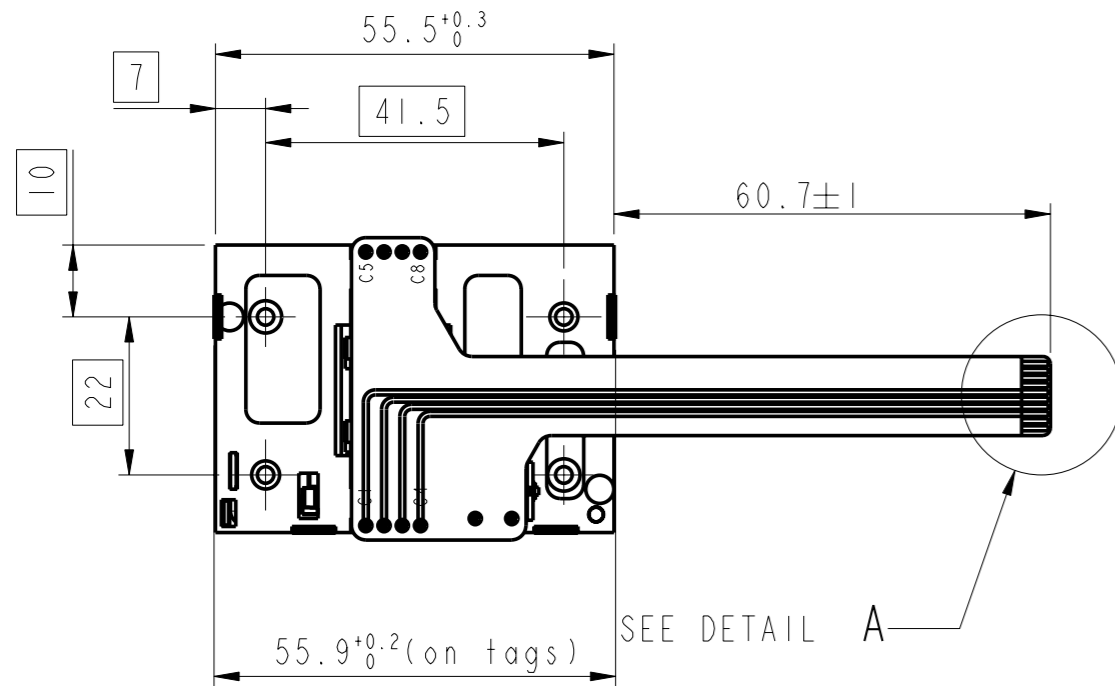

SEE DETAIL B

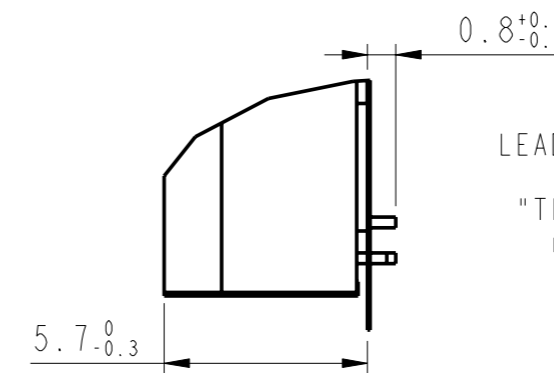

LEAD FREE VERSION:

"This product meets European Union Directives and other country regulations as described in GS-22-008"

DETAIL B  
 SCALE 5:1

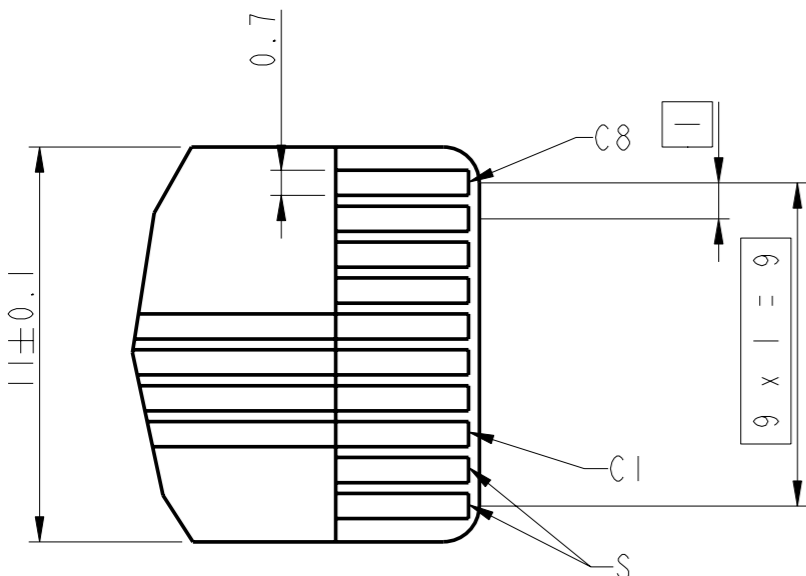

DETAIL A  
 SCALE 5:1

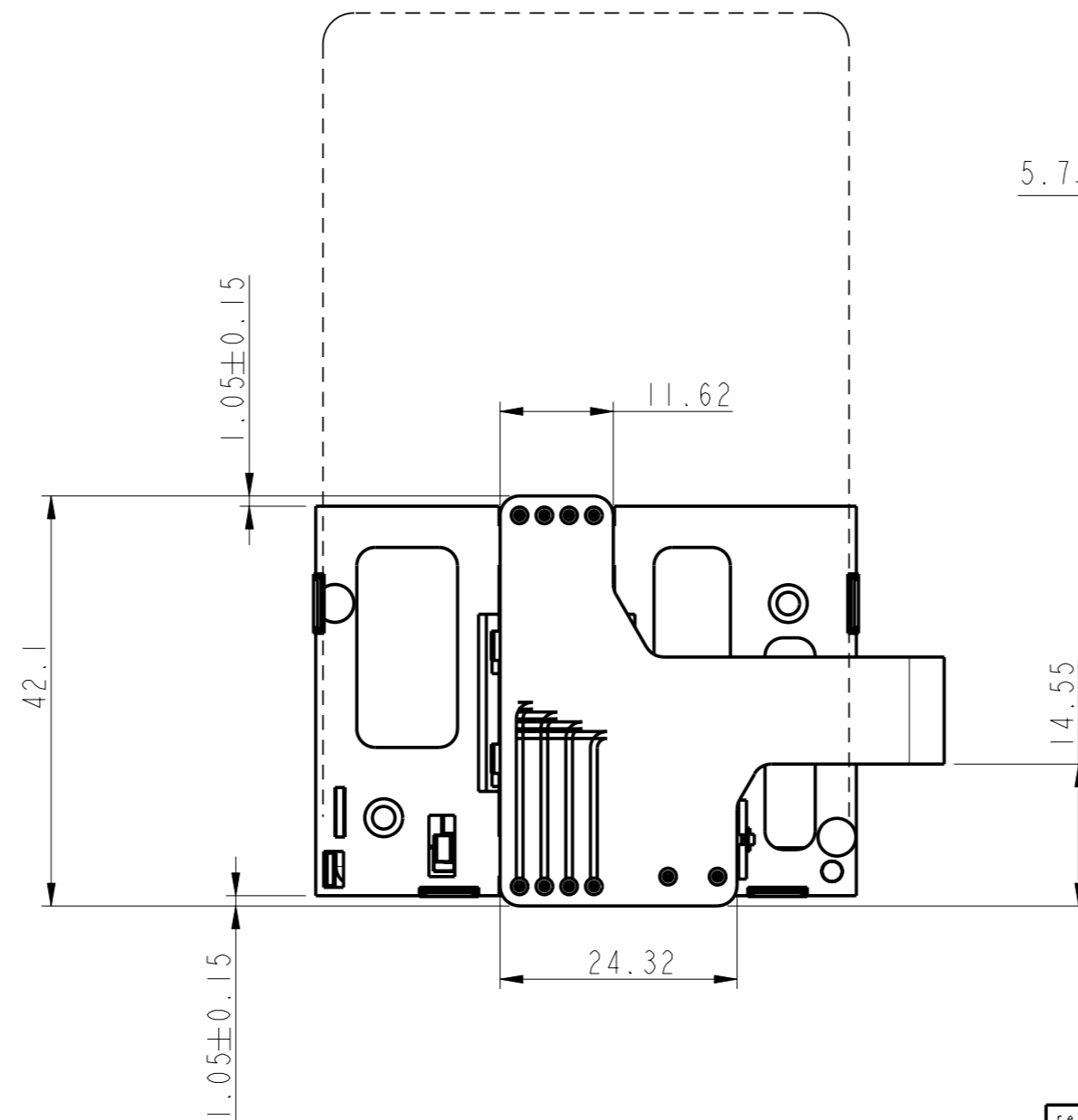

General Tolerances			
0 to 10mm:	±0.1mm		
10 to 30mm:	±0.15mm		
30 to 60mm:	±0.2mm		
60 and more:	±0.3mm		

rev	ecn no	dr	date
I	Creation	JTA	02/12/10
A	LS3031	JTA	03/03/26
B	LS3077	MPE	03/09/17
C	LS3088	MPE	03/10/16
D	104-0051	DTK	04/07/17
E	105-0181	NT	05/10/04
F	106-0078	DTK	06/06/19

www.fciconnect.com		surface --	tolerance std	projection	mm	
		ISO 1302	ISO 406 ISO 1101	ANGULAR	Scale	
		TOLERANCES UNLESS OTHERWISE SPECIFIED			3:2	
Dr	TARON	02/12/10	0.x	±	size	A2
Eng	TARON	02/12/10	0.xx	±	ECN	106-0078
Chr	DILIP THOMAS	06/06/19	0.xxx	±	Product family	MOBILE I/O
Appr	K.V.SIVADAS	06/06/19	Product family		MOBILE I/O	Spec ref
FCI		E02-SIDE-FLEX		10020343		Rev.
		SMART CARD READER VXX 27790		CUSTOMER		F
catalog no		See Table		sheet 1 of 1		