



PRODUCT SPECIFICATION



LANGUAGE

JAPANESE
ENGLISH

【 4. 性能 PERFORMANCE 】

4-1.電氣的性能 Electrical performance

項 目 Item		条 件 Test Condition	規 格 Requirement
4-1-1	接 触 抵 抗 Contact Resistance	コネクタを嵌合させ、開放電圧 20mV以下、短絡電流 10mA にて測定する。(導体抵抗は除く) (JIS C5402 5.4) Mate connectors and measured by dry circuit, 20mV MAX., 10mA. (Subtract the conductor resistance of the wire.) (JIS C5402 5.4)	20 milliohms MAX.
4-1-2	絶 縁 抵 抗 Insulation Resistance	コネクタを嵌合させ、隣接するターミナル間及びターミナル、アース間に、DC 500Vを印加し測定する。 (JIS C5402 5.2/MIL-STD-202 試験法 302) Mate connectors and apply 500V DC between adjacent terminal and ground. (JIS C5402 5.2/MIL-STD-202 Method 302)	1000 Megohms MIN.
4-1-3	耐 電 圧 Dielectric Strength	コネクタを嵌合させ、隣接するターミナル間及びターミナル、アース間に、AC(rms) 800V (実効値) を1分間 印加する。感度電流 2mA (JIS C5402 5.1/MIL-STD-202 試験法 301) Mate connectors and apply 800V AC(rms) for 1 minute between adjacent terminal or ground. Trip current 2mA. (JIS C5402 5.1/MIL-STD-202 Method 301)	異常なきこと No Breakdown
4-1-4	圧着部接触抵抗 Contact Resistance on Crimped Portion	ターミナルに適合電線を圧着し、開放電圧20mV以下、短絡電流 10mA以下 にて測定する。 Crimp the applicable wire to the terminal, measured by dry circuit, 20mV MAX., 10mA MAX. .	5 milliohms MAX.

B	REVISE ON PC ONLY		TITLE: 2.0 mm PITCH WIRE TO BOARD CONNECTOR SINGLE DIP TYPE 製品仕様書	
	SEE SHEET 1 OF 13			THIS DOCUMENT CONTAINS INFORMATION THAT IS PROPRIETARY TO MOLEX INC. AND SHOULD NOT BE USED WITHOUT WRITTEN PERMISSION
	REV.	DESCRIPTION		
DOCUMENT NUMBER PS-503658-001			FILE NAME PS503658001.doc	
			SHEET 2 OF 13	
EN-37(019)				



PRODUCT SPECIFICATION



LANGUAGE

JAPANESE
ENGLISH

4 - 2. 機械的性能 Mechanical Performance

項目 Item		条件 Test Condition		規格 Requirement
4-2-1	挿入力及び抜去力 Insertion and Withdrawal Force	毎分25±3mmの速さで挿入、抜去を行う。 Insert and withdraw connectors at the speed rate of 25±3mm/minute.		第 6 項参照 Refer to paragraph 6
4-2-2	圧着部引張強度 Crimping Pull Out Force	圧着されたターミナルを治具に 固定し、電線を軸方向に 毎分25±3mmの速さで引張る。 (JIS C5402 6.8) Fix the crimped terminal, apply axial pull out force on the wire at the speed rate of 25±3mm/minute. (JIS C5402 6.8)	AWG#22	39.2N{ 4.0kgf }MIN.
			AWG#24	29.4N{ 3.0kgf }MIN.
			AWG#26	19.6N{ 2.0kgf }MIN.
4-2-3	ターミナル 挿入力 Terminal Insertion Force	圧着されたターミナルをハウジングに挿入する。 Insert the crimped terminal into the housing.		9.8N { 1.0kgf } MAX.
4-2-4	ターミナル 保持力 Terminal Retention Force	ハウジングに装着されたターミナルを 毎分 25±3mm の速さで引張る。 Apply axial pull out force at the speed rate of 25±3mm/min on the crimp terminal assembled in the housing.		9.8N { 1.0kgf } MIN.
4-2-5	ピン保持力 Pin Retention Force	毎分 25±3mm の速さでピンを軸方向に押す。 Apply axial push force at the speed rate of 25±3mm/minute on the pin assembled in the housing.		9.8N { 1.0 kgf } MIN.
4-2-6	強制抜去力 Compulsion Withdrawal Force	コネクタを嵌合させ、ロックを解除せずに 毎分25±3mmの速さで軸方向に引張る。 (試験サンプルは、端子装着状態とする。) Mated connectors, and apply axial pull out force at the speed rate of 25±3mm/minute when it not discharge lock. (Test sample have pin/terminal.)		3極以下 14.7N { 1.5 kgf } MIN. 4極以上 29.4N { 3.0 kgf } MIN.

B	REVISE ON PC ONLY		TITLE: 2.0 mm PITCH WIRE TO BOARD CONNECTOR SINGLE DIP TYPE 製品仕様書	
	SEE SHEET 1 OF 13			THIS DOCUMENT CONTAINS INFORMATION THAT IS PROPRIETARY TO MOLEX INC. AND SHOULD NOT BE USED WITHOUT WRITTEN PERMISSION
	REV.	DESCRIPTION		
DOCUMENT NUMBER PS-503658-001			FILE NAME PS503658001.doc SHEET 3 OF 13	
EN-37(019)				



PRODUCT SPECIFICATION



LANGUAGE

JAPANESE
ENGLISH

4-3. その他 Environmental Performance and Others

項目 Item		条件 Test Condition	規格 Requirement	
4-3-1	繰り返し挿抜 Repeated Insertion / Withdrawal	1分間 10回 以下の速さで、挿入、抜去を 30回 繰返す。 When mated up to 30 cycles repeatedly by the rate of 10 cycles per minute.	接触抵抗 Contact Resistance	40 milliohms MAX.
4-3-2	温度上昇 Temperature Rise	コネクタを嵌合させ、各極が直列になる様に 接続した状態で、最大許容電流を通電し、温 度が飽和した時の温度上昇分を熱電対で測定 する。 With connector mated, measure the temperature rise by applying maximum tolerance current.	温度上昇 Temperature Rise	30 °C MAX.
4-3-3	耐振動性 Vibration	DC 1mA 通電状態にて、嵌合軸を含む互いに 垂直な3方向に 掃引割合10~55~10 Hz/分、 全振幅 1.5mm の振動を各2時間 加える。 (MIL-STD-202 試験法 201) Mate connectors and subject to the following vibration conditions, for a period of 2 hours in each of 3 mutually perpendicular axes, passing DC 1mA during the test. Amplitude : 1.5mm P-P Frequency : 10~55~10 Hz in 1.0 minute. Duration : 2 hours in each X.Y.Z.axes. (MIL-STD-202 Method 201)	外観 Appearance	異状なきこと No Damage
			接触抵抗 Contact Resistance	40 milliohms MAX.
			瞬断 Discontinuity	1.0 microsecond MAX.
4-3-4	耐衝撃性 Mechanical Shock	DC 1mA 通電状態にて、嵌合軸を含む互いに 垂直な 6方向 に 490m/s ² { 50G }、作用時間 11msecの衝撃を 各3回 加える。 (JIS C60068-2-27/MIL-STD-202 試験法213) Mate connectors and subject to the following shock conditions. 3 shocks shall be applied along 3 mutually perpendicular axes, passing DC 1 mA current during the test. (Total of 18 shocks) Test pulse : Half Sine Peak value : 490 m/s ² (50 G) Duration : 11 msec (JIS C60068-2-27/ MIL-STD-202 Method 213)	外観 Appearance	異状なきこと No Damage
			接触抵抗 Contact Resistance	40 milliohms MAX.
			瞬断 Discontinuity	1.0 microsecond MAX.

REVISE ON PC ONLY		TITLE: 2.0 mm PITCH WIRE TO BOARD CONNECTOR SINGLE DIP TYPE 製品仕様書	
B	SEE SHEET 1 OF 13	THIS DOCUMENT CONTAINS INFORMATION THAT IS PROPRIETARY TO MOLEX INC. AND SHOULD NOT BE USED WITHOUT WRITTEN PERMISSION	
REV.	DESCRIPTION		
DOCUMENT NUMBER PS-503658-001		FILE NAME PS503658001.doc	SHEET 4 OF 13
EN-37(019)			



PRODUCT SPECIFICATION



LANGUAGE

JAPANESE
ENGLISH

項 目 Item		条 件 Test Condition	規 格 Requirement	
4-3-5	耐熱性 Heat Resistance	コネクタを嵌合させ、85±2°C の雰囲気中に96時間放置後取り出し、1~2時間室温に放置する。 (JIS C60068-2-2/MIL-STD-202 試験法 108) Mate connectors and expose to 85±2°C for 96 hours. Upon completion of the exposure period, the test specimens shall be conditioned at ambient room conditions for 1 to 2 hour , after which the specified measurements shall be performed. (JIS C60068-2-2/MIL-STD-202 Method 108)	外 観 Appearance	異常なきこと No Damage
			接 触 抵 抗 Contact Resistance	40 milliohms MAX
4-3-6	耐寒性 Cold Resistance	コネクタを嵌合させ、-40±3°C の雰囲気中に96時間 放置後取り出し、1~2時間 室温に放置する。(JIS C60068-2-1) Mate connectors and expose to -40±3°C for 96 hours. Upon completion of the exposure period, the test specimens shall be conditioned at ambient room conditions for 1 to 2 hour, after which the specified measurements shall be performed. (JIS C60068-2-1)	外 観 Appearance	異常なきこと No Damage
			接 触 抵 抗 Contact Resistance	40 milliohms MAX.
4-3-7	耐湿性 Humidity	コネクタを嵌合させ、40±2°C、相対湿度90~95% の雰囲気中に 96時間 放置後取り出し、1~2時間 室温に放置する。 (JIS C60068-2-3/MIL-STD-202 試験法 103) Mate connectors and expose to 40±2°C, relative humidity 90 to 95% for 96 hours. Upon completion of the exposure period, the test specimens shall be conditioned at ambient room conditions for 1 to 2 hours, after which the specified measurements shall be performed. (JIS C60068-2-3/MIL-STD-202 Method 103)	外 観 Appearance	異常なきこと No Damage
			接 触 抵 抗 Contact Resistance	40 milliohms MAX.
			絶 縁 抵 抗 Insulation Resistance	100 Megohm MIN.
			耐 電 圧 Dielectric Strength	4-1-3項満足のこと Must meet 4-1-3

REVISE ON PC ONLY		TITLE: 2.0 mm PITCH WIRE TO BOARD CONNECTOR SINGLE DIP TYPE 製品仕様書	THIS DOCUMENT CONTAINS INFORMATION THAT IS PROPRIETARY TO MOLEX INC. AND SHOULD NOT BE USED WITHOUT WRITTEN PERMISSION
B	SEE SHEET 1 OF 13		
REV.	DESCRIPTION		
DOCUMENT NUMBER PS-503658-001		FILE NAME PS503658001.doc	SHEET 5 OF 13
EN-37(019)			



PRODUCT SPECIFICATION



LANGUAGE

JAPANESE
ENGLISH

項 目 Item		条 件 Test Condition	規 格 Requirement	
4-3-8	温度サイクル Temperature Cycling	<p>コネクタを嵌合させ、$-55\pm 3^{\circ}\text{C}$ に 30分、$+85\pm 2^{\circ}\text{C}$ に 30分 これを1サイクルとし、5サイクル 繰返す。 但し、温度移行時間は 5分以内 とする。 試験後1~2時間 室温に放置する。 (JIS C0025)</p> <p>Mate connectors and subject to the following conditions for 5 cycles. Upon completion of the exposure period, the test specimens shall be conditioned at ambient room conditions for 1 to 2hours, after which the specified measurements shall be performed. 5 cycles of : a) $-55\pm 3^{\circ}\text{C}$ 30 minutes b) $+85\pm 2^{\circ}\text{C}$ 30 minutes (JIS C0025)</p>	外 観 Appearance	異常なきこと No Damage
			接 触 抵 抗 Contact Resistance	40 milliohms MAX.
4-3-9	塩 水 噴 霧 Salt Spray	<p>コネクタを嵌合させ、$35\pm 2^{\circ}\text{C}$ にて $5\pm 1\%$ 重量比の塩水を 48 ± 4時間噴霧し、試験後 常温で水洗いした後、室温で乾燥させる。 (JIS C60068-2-11/MIL-STD-202 試験法101)</p> <p>Mate connectors and expose to the following salt mist conditions. Upon completion of the exposure period, salt deposits shall be removed by a gentle wash or dip in running water, after which the specified measurements shall be performed. NaCl solution Concentration : $5\pm 1\%$ Spray time : 48 ± 4 hours Ambient temperature : $35\pm 2^{\circ}\text{C}$ (JIS 60068-2-11/MIL-STD-202 Method 101)</p>	外 観 Appearance	異常なきこと No Damage
			接 触 抵 抗 Contact Resistance	40 milliohms MAX.
4-3-10	耐亜硫酸ガス SO ₂ Gas	<p>コネクタを嵌合させ、$40\pm 2^{\circ}\text{C}$にて 50 ± 5ppmの亜硫酸ガス中に24時間放置する。 Mated connectors and expose to the conditions of 50 ± 5ppm SO₂ gas ambient temperature $40\pm 2^{\circ}\text{C}$ for 24 hours.</p>	外 観 Appearance	異常なきこと No Damage
			接 触 抵 抗 Contact Resistance	40 milliohms MAX.

B	REVISE ON PC ONLY		TITLE: 2.0 mm PITCH WIRE TO BOARD CONNECTOR SINGLE DIP TYPE 製品仕様書 THIS DOCUMENT CONTAINS INFORMATION THAT IS PROPRIETARY TO MOLEX INC. AND SHOULD NOT BE USED WITHOUT WRITTEN PERMISSION
	SEE SHEET 1 OF 13		
	REV.	DESCRIPTION	
DOCUMENT NUMBER PS-503658-001		FILE NAME PS503658001.doc	SHEET 6 OF 13
EN-37(019)			



PRODUCT SPECIFICATION



LANGUAGE

JAPANESE
ENGLISH

項 目 Item		条 件 Test Condition	規 格 Requirement	
4-3-11	耐アンモニア性 Ammonia gas	コネクタを嵌合させ、濃度28%のアンモニア水を入れた容器中に40分間放置する。 (1Lに対して25mLの割合) Mated connectors and expose to the conditions of NH3 gas evaporating from 28% Ammonia solution for 40 minutes.	外 観 Appearance	異常なきこと No Damage
			接 触 抵 抗 Contact Resistance	40 milliohms MAX.
4-3-12	半田付け性 Solderability	ピンをフラックスに浸し、本体の取付け基準面より1.2mm迄、245±3°Cの半田に3±0.5秒浸す。 Soldering Time : 3±0.5 sec. Solder Temperature : 245±5°C	濡れ性 Solder Wetting	浸漬面積の90%以上 90% of immersed area must show no voids, pin holes.
4-3-13	半田耐熱性 Resistance to Soldering Heat	ディップの場合 <u>Soldering bath method</u> ピンの本体取付け基準面より1.2mm迄、260±5°Cの半田に5±0.5秒浸す。 Soldering Time : 5±0.5 sec. Solder Temperature : 260±5°C	外 観 Appearance	端子ガタ、割れ等 異常なきこと No Damage
		(手半田時) <u>Soldering iron method</u> 370~400°Cの半田コテにて最大5秒加熱する。但し、端ピンに異常な加圧のないこと。 <u>Soldering iron method</u> Soldering Time : 5 sec. MAX. Solder Temperature : 370~400°C However, without too much pressure to the terminal pin.		

() : 参考規格 Reference Standard
{ } : 参考単位 Reference Unit

【 5. 外観形状、寸法及び材質 PRODUCT SHAPE, DIMENSIONS AND MATERIALS 】

1. 製品寸法 Dimensions of product
図面参照 Refer to the drawing.

REVISE ON PC ONLY	B	SEE SHEET 1 OF 13	TITLE: 2.0 mm PITCH WIRE TO BOARD CONNECTOR SINGLE DIP TYPE 製品仕様書
		REV.	DESCRIPTION
DOCUMENT NUMBER PS-503658-001		FILE NAME PS503658001.doc	SHEET 7 OF 13



PRODUCT SPECIFICATION



LANGUAGE

JAPANESE
ENGLISH

【 6. 挿入力及び抜去力 INSERTION / WITHDRAWAL FORCE 】

極 数 No. of CKT	単位 UNIT	挿入力 (最大値) Insertion (MAX.)			抜去力 (最小値) Withdrawal (MIN.)		
		初回 1st	6 回目 6th	30 回目 30th	初回 1st	6 回目 6th	30 回目 30th
4	N { kgf }	12.9 { 1.32 }	13.9 { 1.42 }	20.9 { 2.13 }	0.7 { 0.07 }	0.7 { 0.07 }	0.7 { 0.07 }
5	N { kgf }	16.1 { 1.64 }	17.1 { 1.74 }	24.1 { 2.46 }	0.9 { 0.09 }	0.9 { 0.09 }	0.9 { 0.09 }
6	N { kgf }	19.3 { 1.97 }	20.3 { 2.07 }	27.3 { 2.79 }	1.1 { 0.11 }	1.1 { 0.11 }	1.1 { 0.11 }
8	N { kgf }	25.7 { 2.62 }	26.7 { 2.72 }	33.7 { 3.44 }	1.5 { 0.15 }	1.5 { 0.15 }	1.5 { 0.15 }
10	N { kgf }	32.1 { 3.28 }	33.1 { 3.38 }	40.1 { 4.10 }	1.9 { 0.19 }	1.9 { 0.19 }	1.9 { 0.19 }
12	N { kgf }	38.5 { 3.93 }	39.5 { 4.03 }	46.5 { 4.74 }	2.3 { 0.23 }	2.3 { 0.23 }	2.3 { 0.23 }
14	N { kgf }	44.9 { 4.58 }	45.9 { 4.68 }	52.9 { 5.40 }	2.7 { 0.27 }	2.7 { 0.27 }	2.7 { 0.27 }
15	N { kgf }	48.1 { 4.91 }	49.1 { 5.01 }	56.1 { 5.72 }	2.9 { 0.29 }	2.9 { 0.29 }	2.9 { 0.29 }

※ロックを解除して測定 Released lock, and measure.

{ } : 参考単位

Reference Unit

REVISE ON PC ONLY		TITLE: 2.0 mm PITCH WIRE TO BOARD CONNECTOR SINGLE DIP TYPE 製品仕様書	THIS DOCUMENT CONTAINS INFORMATION THAT IS PROPRIETARY TO MOLEX INC. AND SHOULD NOT BE USED WITHOUT WRITTEN PERMISSION
B	SEE SHEET 1 OF 13		
REV.	DESCRIPTION		
DOCUMENT NUMBER PS-503658-001		FILE NAME PS503658001.doc	SHEET 8 OF 13
EN-37(019)			



PRODUCT SPECIFICATION



LANGUAGE

JAPANESE
ENGLISH

【 7. 取り扱い上の注意事項 INSTRUCTION UPON USAGE 】

1. 本製品のプラスチック部に黒点、気泡等が確認される場合や色合いが異なる場合（経年変化によるハウジングの変色を含む）が御座いますが、製品性能に影響は御座いません。

There is no influence in the product performance though the black spot or bubble etc. might be confirmed to the plastic part of this product and the shade might be different (discoloration by secular distortion etc.).

2. 本製品は錫メッキを使用している為、外観に摺動痕がつく場合が御座いますが、製品性能に影響は御座いません。

The wound of friction might adhere to externals because the tin plating is used for the tail and nail.
But there is no influence in the product performance.

3. 本製品のハウジング及びメッキ表面に多少の傷が確認される場合がありますが、製品性能に問題御座いません。

A few scratch may be confirmed to the surface of the housing and the plating of this product, however,
There is no problem in the product performance.

4. 本製品のプラスチック部が紫外線により変色する場合がありますが、製品性能には問題御座いません。

Discoloration of the plastic part of this product can result from exposure to ultraviolet light.
There is not problem in the product performance.

5. 推奨保管条件での保管をお願い致します。

Please store the products under recommended storage condition.

6. 梱包品の推奨保管条件を超えた場合は外観、半田付け性を確認の上ご使用下さい。

Please use it after confirming externals and soldering when the storage condition of packing goods is over recommended storage condition.

7. 本製品の一般性能確認はリジット基板にて実施おります。フレキシブル基板等の特殊な基板へ実装する場合は事前に実装確認等を行った上でご使用願います。

The product performance was tested using rigid printed circuit board. In case the product needs to be reflowed onto flexible circuit board, please conduct a reflow test on the flexible circuit board in advance.

8. 半田実装部の未半田は、ターミナル脱落、ピン間ショート、ターミナル座屈、またコネクタの基板からの外れが懸念されます。従って全てのターミナルテール部に半田付けを行って下さい。

If you leave any soldering area on this product open, there may be the possibility of a missing terminal short circuiting between pins, terminal buckling or the potential for the connector to come off of the printed circuit board. Therefore, please solder all of the terminals and fitting nails on the printed circuit board.

9. 本製品を結露・水濡れが発生する環境でのご使用の場合は、適切な防滴処置をお願い致します。

結露・水濡れにより、回路間で絶縁不良を起こす可能性が御座います。

When this product is used at a place where exposure to water could be expected, please handle with appropriate care to avoid damage from water.

There is a possibility of causing insulated malfunction between the circuits.

10. コネクタの性能を損なう恐れがある為、コネクタの洗浄は、行わないで下さい。

Please do not conduct any "washing process" on the connector because it may damage the product' s function.

	REVISE ON PC ONLY		TITLE: 2.0 mm PITCH WIRE TO BOARD CONNECTOR SINGLE DIP TYPE 製品仕様書
	B	SEE SHEET 1 OF 13	
	REV.	DESCRIPTION	THIS DOCUMENT CONTAINS INFORMATION THAT IS PROPRIETARY TO MOLEX INC. AND SHOULD NOT BE USED WITHOUT WRITTEN PERMISSION
DOCUMENT NUMBER PS-503658-001			FILE NAME PS503658001.doc
			SHEET 9 OF 13
EN-37(019)			



1 1. コネクタの詳細な取り扱いにつきましては、別紙の 2.0 W/B CONN. SINGLE のコネクタ取り扱い説明書 (AS-503658-001)を参照して下さい。
Please refer to the manual of the 2.0 W/B connector. SINGLE series for the detailed handling of the connector. (AS-503658-001)

- ① 嵌合時にリセプタクルハウジングの矢印で示す部位を押し、嵌合して下さい。
電線やハウジングのロック部を押した場合、これらが破損する恐れがありますのでお避け下さい。
Please push the part directed by FIG.1 at the time of mate.
It may damage, when electric wires or lock part of the receptacle housing are pushed.



図 1 / FIG.1

- ② コネクタの嵌合を取り外す際は、必ずロックを解除して行って下さい。
電線はまとめて軽く掴み、指の平全体で確実にロックを解除し、ゆっくり引き抜いて下さい。
When unmated connectors, positive locks shall be released.

- 1 2. 本製品をご使用時に取り付けられた電線・プリント基板の共振や、機器の回転構造や可動部分の動作によりコネクタ嵌合部（接点部）が常に動いてしまう状態での御使用は避けて下さい。
接触部の摺動磨耗等による 接触不良の原因となります。従って、機器内で電線・プリント基板を固定し、共振を抑える等の処置をお願い致します。
Please do not use the connector in a condition where the wire, the printed circuit board, or the contact area is experiencing a sympathetic vibration of wires and printed circuit board, and constant movement of devices. This may cause a defect in the contact due to the contact area being worn down. Therefore, please fix wires and printed circuit board on the chassis, and reduces sympathetic vibration.
- 1 3. 基板実装前後に端子に触らないで下さい。
Please do not touch the terminals and fitting nails before or after reflowing the connector onto the printed circuit board.
- 1 4. コネクタ嵌合状態で基板の持ち運び等コネクタに負荷が掛かる作業は行わないようにして下さい。コネクタ破損等の原因となる場合が御座います。
Please do not do work that the load hangs in the connector like the carrying of the substrate etc. with the connector engages. There is a case where it causes the connector damage etc.

REVISE ON PC ONLY		TITLE:	
B	SEE SHEET 1 OF 13	2.0 mm PITCH WIRE TO BOARD CONNECTOR SINGLE DIP TYPE	
	REV.	DESCRIPTION	製品仕様書
DOCUMENT NUMBER PS-503658-001		THIS DOCUMENT CONTAINS INFORMATION THAT IS PROPRIETARY TO MOLEX INC. AND SHOULD NOT BE USED WITHOUT WRITTEN PERMISSION	
		FILE NAME PS503658001.doc	SHEET 10 OF 13
EN-37(019)			

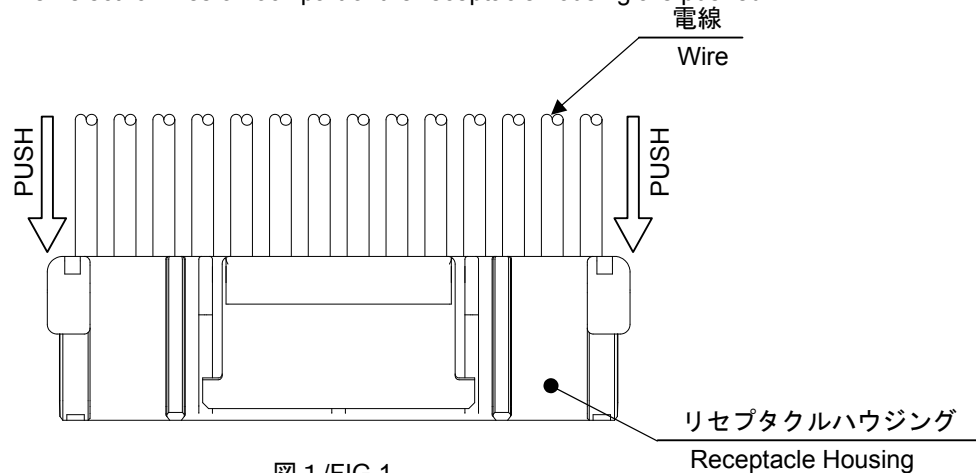

PRODUCT SPECIFICATION



LANGUAGE

JAPANESE
ENGLISH

- 1 5. 基板実装後に基板を直接積み重ねない様に注意して下さい。
Please do not stack the printed circuit board directly after mounted the connector on it.
- 1 6. 実装後において手半田コテによるリペアを行なう際は、必ず仕様書掲載の条件以内で行なって下さい。条件を超えて実施した場合、端子の抜け、接点ギャップの変化、モールドの変形、溶融等が原因により破損の原因になります。
Please conduct it under the condition of the specifications when repairing by hand soldering iron after mounting. In the case of practicing beyond the condition, the backlash, the change in the contact gap, the deformation of the mold and the melting, etc. may cause a damage.
- 1 7. 半田コテによる手修正を行なう際、過度の半田やフラックスを使用しないで下さい。半田上がりやフラックス上がりにより接触、機能不良に至る場合が御座います。
When conducting manual repairs using a soldering iron, please do not use more solder and flux than needed. This may cause solder wicking and flux wicking issues, and it will eventually cause a contact defect and functional issues.
- 1 8. 実装機によってコネクタに負荷が加わると変形、破損する場合がありますので事前にご確認下さい。
If there is accidental contact with the connector while it is going through the reflow machine, there may be deformation or damage caused to the connector. Please check to prevent this.
- 1 9. コネクタのみで基板を支えることは避け、コネクタ以外での基板固定対策を行って下さい。
Please do not use the connector alone to provide mechanical support for the printed circuit board (PCB). Please ensure that there is a fixed structure on the phone chassis or other component support for the PCB.
- 2 0. 嵌合後、コネクタピッチ方向、スパン方向及び回転方向への負荷がかかるような動作またはセットはしないでください。コネクタ破壊や半田クラックを引き起こします。
After mated the connector, please do not allow the printed circuit boards to apply pressure on the connector in either the pitch direction or the span direction. It may cause damage to the connector and may crack the soldering.
- 2 1. 本製品及び加工工程品（仕掛品）や加工品（ハーネス等）の梱包及び輸送・保管時にはコネクタに負荷が加わらないようご注意ください。変形、破損などの原因となり、コネクタの性能不良の原因となります。
Please try to prevent any external forces or shock from being applied to the connector while the cable assembly is in process, when it is being packaged, or while it is in transportation. This may cause deformation and damage to the connector and cause a defect in the product's performance.
- 2 2. ハーネス加工品及びコネクタ嵌合後の電線の引き回しの際、引張りによる力が加わりますと、接点部、結線部（圧着部）やロック部（端子ロック部）が損傷を受け、接触不良の原因となります。
電線の引回し配線をされる場合、コネクタに無理な外力が加わらないように、電線に緩みを持たせ、余裕を持たせる処置をして下さい。
The cable assembly should not have a constant stress or pulling force applied on it when it is in the mated condition. This phenomenon may damage the contact area or wiring area (crimping).
Therefore, when designing the wire positioning, please ensure that there is enough length of wire to avoid stress on the connector.

B	REVISE ON PC ONLY	SEE SHEET 1 OF 13	TITLE: 2.0 mm PITCH WIRE TO BOARD CONNECTOR SINGLE DIP TYPE 製品仕様書	
	REV.		DESCRIPTION	THIS DOCUMENT CONTAINS INFORMATION THAT IS PROPRIETARY TO MOLEX INC. AND SHOULD NOT BE USED WITHOUT WRITTEN PERMISSION
DOCUMENT NUMBER PS-503658-001			FILE NAME PS503658001.doc	SHEET 11 OF 13
EN-37(019)				



2 3. コネクタに適用できる電線は、原則として錫メッキつき付軟銅撚り線です。
 その他の電線の使用については別途ご確認下さい。
 The applicable wire for this connector, in principle, is tin-plated copper stranded wire.
 Please consult us and evaluate it in advance when using other wires.

2 4. リセプタクルハウジング (503658-**00) に端子 (503657-1*00) を挿入する際、図1に示した正規の方向から端子が突き当たるまで挿入して下さい。又、挿入後軽く電線を引張って端子が抜け出さないか確認下さい。
 When inserting the terminal (503657-1*00) into the receptacle housing (503658-**00), please ensure that the terminal is inserted completely and touches the end of the receptacle housing. Please insert the terminal in the correct direction as showing in figure 1. Also, please pull the wire lightly after inserting the terminal to ensure that the terminal is fully inserted and can not be pulled out.

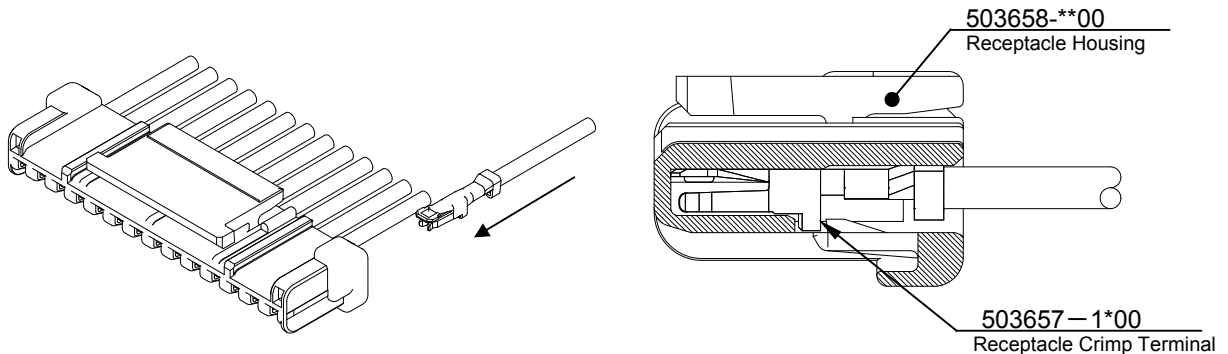

<図1 端子挿入方向>

<図2 端子装着状態>

2 5. 治具等を使用し、圧着端子を抜いた場合には、ランスの変形によりランス強度が低下する為、端子再装着後の端子保持力が極端に低下します。そのため、圧着端子のリペアの際には新しいハウジングを必ず使用して下さい。
 When extracting a crimp terminal from the housing using a jig, it may deform the housing lance and therefore reduce the terminal retention force after re-inserting of the terminal. Therefore, please ensure to use a new housing after repairing the crimp terminals.

2 6. 本製品をご使用時には、1 PIN当りの定格以上の電流を複数の回路に分岐しての使用は避けて下さい。
 When using this product, please ensure that the specification for rated current per circuit is followed. Do not allow the sum of the current used on several circuits to exceed the maximum allowable current.

2 7. 活電状態の電気回路で、挿入、抜去ができることを前提に作られておりません。
 スパーク等による危険の発生、性能不良につながりますので、活電状態での挿入、抜去はしないで下さい。
 This product is not designed for the mating and unmating of the connectors to be performed under the condition of an active electrical circuit. It may cause a spark and product defect if the connectors are mated and unmated in this way.

B	REVISE ON PC ONLY		TITLE: 2.0 mm PITCH WIRE TO BOARD CONNECTOR SINGLE DIP TYPE 製品仕様書
	SEE SHEET 1 OF 13		
REV.	DESCRIPTION		
DOCUMENT NUMBER PS-503658-001			FILE NAME PS503658001.doc
			SHEET 12 OF 13
EN-37(019)			



PRODUCT SPECIFICATION



LANGUAGE

JAPANESE
ENGLISH

REV.	REV. RECORD	DATE	EC NO.	WRITTEN:	CH'K:
A	RELEASED	'10/08/04	J2011-0197	S.KUROSE	K.ASAKAWA
B	REVISED	'11/07/28	J2012-0117	S.SATO	K.ASAKAWA

B	REVISE ON PC ONLY		TITLE: 2.0 mm PITCH WIRE TO BOARD CONNECTOR SINGLE DIP TYPE 製品仕様書 <small>THIS DOCUMENT CONTAINS INFORMATION THAT IS PROPRIETARY TO MOLEX INC. AND SHOULD NOT BE USED WITHOUT WRITTEN PERMISSION</small>
	SEE SHEET 1 OF 13		
	REV.	DESCRIPTION	
DOCUMENT NUMBER PS-503658-001			FILE NAME PS503658001.doc SHEET 13 OF 13
EN-37(019)			