

NOTICE OF PROPRIETARY RIGHTS: THIS DOCUMENT CONTAINS CONFIDENTIAL DATA, INCLUDING TRADE SECRETS, PROPRIETARY TO TIMES MICROWAVE SYSTEMS. DISCLOSURE OF THIS DATA IS EXPRESSLY CONDITIONED UPON YOUR ASSENT THAT ITS USE IS LIMITED TO USE WITHIN YOUR COMPANY ONLY. ANY OTHER USE IS STRICTLY PROHIBITED WITHOUT THE PRIOR WRITTEN CONSENT OF TIMES MICROWAVE SYSTEMS.

VER	Description	ECN	Name	Date
A	Initial Released	N/A	Patrick	2018/10/20

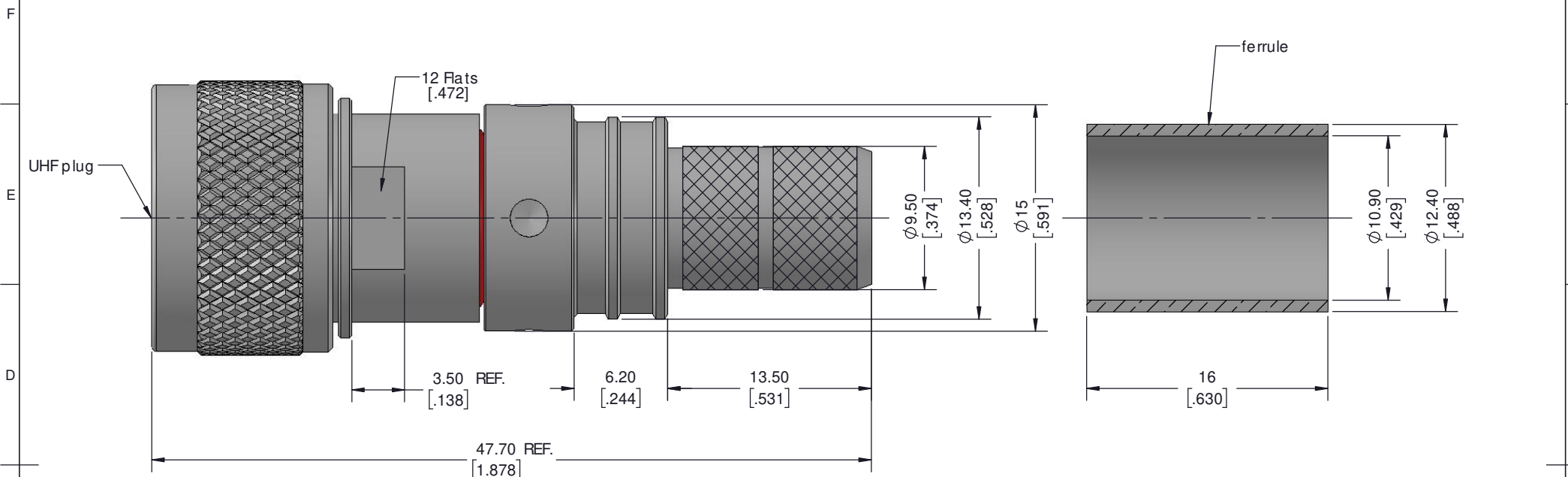

I. MATERIALS & FINISHES			
Component	Material	Finishes	Thk. (u")
Body	Brass	Sn-Ni	100
Contact Pin	Phosphor Bronze	Silver	200
Insulator	PTFE	--	--
Coupling Nut	Brass	Sn-Ni	100
Ferrule	Copper	Sn-Ni	100

II. ELECTRICAL PROPERTIES	
Impedance ( $\Omega$ ):	50
Frequency Range (GHz):	DC~3 GHz
Dielectric Withstanding Voltage (V r.m.s.):	2000
Insulation Resistance (M $\Omega$ ):	$\geq 10000$
VSWR:	$\leq 1.30$ (DC~2.45 GHz)
Insertion Loss (dB, f / GHz):	-0.1 x sqrt (f)

III. ENVIRONMENT PROPERTIES	
Temperature Range:	-40°C~+125°C
Thermal Shock:	MIL-STD-202, Meth. 107, Cond. B
Vibration:	MIL-STD-202, Meth. 204, Cond. B
Shock:	MIL-STD-202, Meth. 213, Cond. G
Climatic Class:	IEC 60068 55/155/21
RoHS:	Compliant

IV. MECHANICAL PROPERTIES	
Center Conductor:	Spring Captive
Outer Conductor:	Crimp
Coupling Nut Torque (in-lbs):	N/A
Cable-Connector Retention Force (lbs):	120
Durability (Cycles):	500

**V. Tooling & Accessories**  
 Stripping Tool: 3192-004/CST-400  
 Crimping Tool: 3190-666/CT-400/300  
 Heat Shrink Tube: 3/4"x2" (3:1) 1 pcs

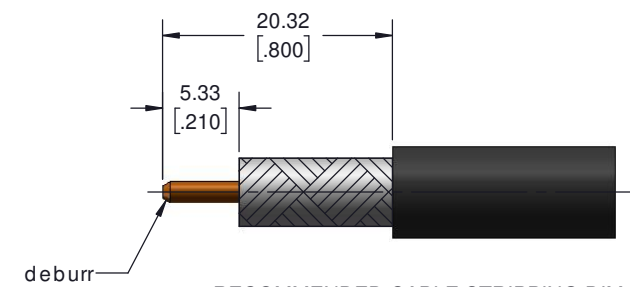

RECOMMENDED CABLE STRIPPING DIM'S  
 Connector Adds: 28.5 mm

Compatible with Standard: IEC 60169-12

UNLESS OTHERWISE SPECIFIED		DFTM Patrick	TIMES MICROWAVE SYSTEMS An Amphenol Company	
ALL DIMENSIONS ARE IN mm MACHINED SURFACES FINISH 1.6 RMS MAX. REMOVE ALL BURRS 0.15X45° MAX. BREAK MACHINE CORNERS 0.15X45° D MAX. FILLET R. TOLERANCES ON DECIMALS X $\pm 0.1$ .XX $\pm 0.05$ ANGLES $\pm 2^\circ$ FRACTIONS $\pm N/A$		DATE 2018/10/20	EZ-400-UM-X	
		CHKD Monica	UHF Male (Plug) Straight Non-Solder Pin No Braid Trim Connector for LMR-400 Cable	
		DATE 2018/10/20		
		APPD Joslen		
Scale: 4:1	Size: A3	CODE IDENT 68999	DATE 2018/10/20	SHT 1/1 3190-8025 REV A