

EZ-BEAM® S12 Series Opposed-Mode Sensor Pairs

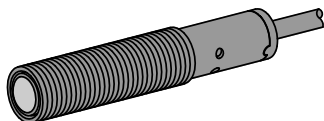

Datasheet



- Economical opposed-mode (beam-break) sensor pairs in 12 mm diameter barrel-style housings
- Sensing range of 15 m (50 ft)
- Totally self-contained; 10 V DC to 30 V DC operation
- Complementary outputs: one normally open, one normally closed; choice of NPN or PNP configuration, 100 mA max. (continuous)
- One output may be used as a marginal signal alarm
- LED status indicators for Power On, Output Overload, Object Sensed, and Low Gain conditions



WARNING:

- **Do not use this device for personnel protection**
- Using this device for personnel protection could result in serious injury or death.
- This device does not include the self-checking redundant circuitry necessary to allow its use in personnel safety applications. A device failure or malfunction can cause either an energized (on) or de-energized (off) output condition.

Models

Visible Red, 680 nm				
Models ¹	Cable	Output Type	Excess Gain	Beam Pattern (Effective beam: 8.1 mm)
S126E Emitter	2 m (6.5 ft)	-		
S126EQP Emitter	Integral 4-pin M8 male quick-disconnect connector			
S12SN6R Receiver	2 m (6.5 ft)	NPN		
S12SN6RQP Receiver	Integral 4-pin M8 male quick-disconnect connector			
S12SP6R Receiver	2 m (6.5 ft)	PNP		
S12SP6RQP Receiver	Integral 4-pin M8 male quick-disconnect connector			

Wiring Diagrams

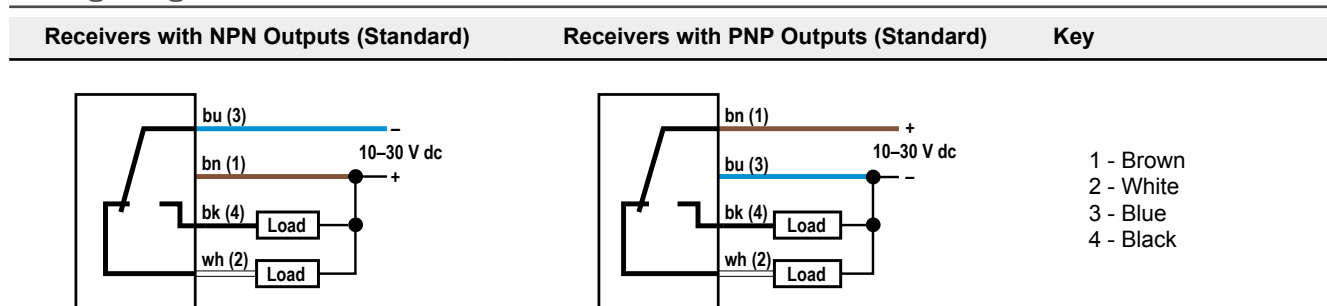

¹ Integral 2 m (6.5 ft) unterminated cable models and 4-pin M8 integral quick disconnect models are listed.

- To order the 9 m (30 ft) PVC cable model, add the suffix "W/30" to the cabled model number.
- Models with a quick disconnect require a mating cordset.



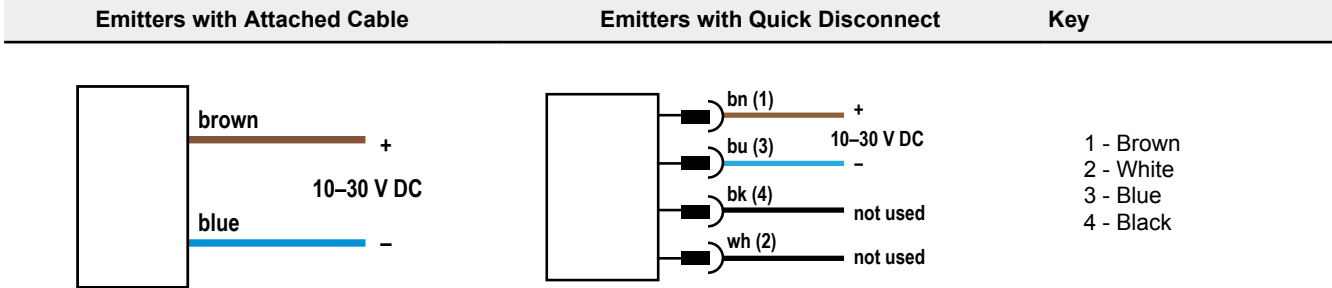
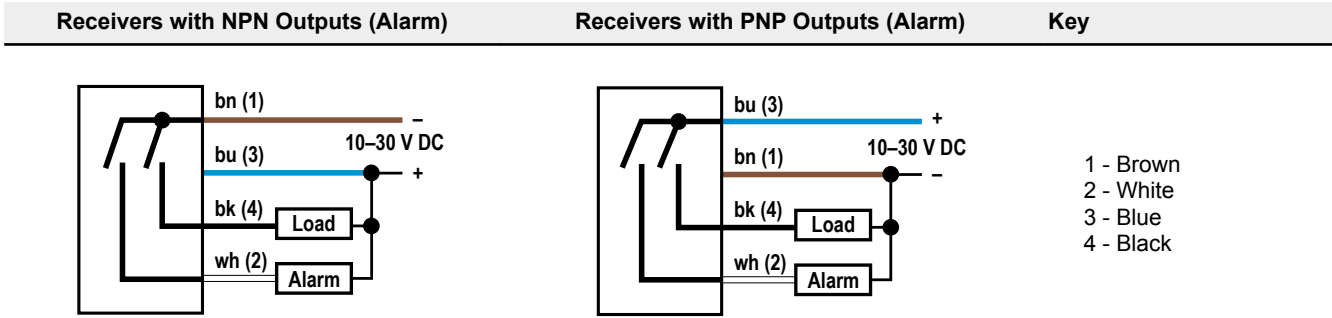

Specifications

Supply Voltage and Current

10 V DC to 30 V DC (10% maximum ripple)
Supply current (exclusive of load current): Opposed Mode Emitters: 25 mA;
Opposed Mode Receivers: 20 mA

Supply Protection Circuitry

Protected against reverse polarity and transient voltages

Output Configuration

SPDT (complementary) solid-state DC switch; choose NPN or PNP models
Light operate: N.O. output conducts when the sensor sees the emitter's modulated light
Dark operate: N.C. output conducts when the sensor sees dark; the N.C. (normally closed) output may be wired as a normally open marginal signal alarm output, depending upon hookup to the power supply (U.S. patent 5087838)

Output Rating

100 mA maximum (each) in standard wiring; when wired for alarm output, the total load may not exceed 100 mA
Off-state leakage current < 1 microamp at 30 V DC
On-state saturation voltage < 1 V at 10 mA DC and < 1.5 V at 150 mA DC

Output Protection Circuitry

Protected against output short-circuit, continuous overload, and false pulse on power-up

Output Response Time

3 milliseconds ON, 1.5 milliseconds OFF
100 millisecond delay on power-up; outputs are non-conducting during this time

Repeatability

375 microseconds; repeatability and response are independent of signal strength

Indicators

Receivers have two LEDs: green and amber
Green solid: power to sensor is on
Green flashing: output is overloaded (DC models only)
Amber solid: normally open output is conducting
Amber flashing: excess gain marginal (1–1.5x) in light condition

Construction

Reinforced thermoplastic polyester housings; polycarbonate lenses; polyurethane end cap

Environmental Rating

Leakproof design rated NEMA 6P (IP67)

Connections

2 m (6.5 ft) unterminated 4-wire PVC-jacketed cable, 9 m (30 ft) unterminated 4-wire PVC-jacketed cable, or Integral 4-pin M8 male quick-disconnect connector

Operating Conditions

Temperature: -40 °C to +70 °C (-40 °F to +158 °F)
Maximum relative humidity: 90% at +50 °C maximum relative humidity (non-condensing)

Vibration and Mechanical Shock

All models meet MIL-STD-202F requirements.
Method 201A (Vibration: 10 Hz to 60 Hz maximum, 0.06 inch (1.52 mm) double amplitude, 10G maximum acceleration).
Method 213B conditions H&I (Shock: 75G with device operating; 100G for non-operation).

Certifications



Banner Engineering
Europe Park Lane,
Culliganlaan 2F bus 3,
1831 Diegem,
BELGIUM

Turck Banner LTD
Blenheim House,
Blenheim Court,
Wickford, Essex SS11
8YT, Great Britain

Dimensions

Figure 1. Cabled Models

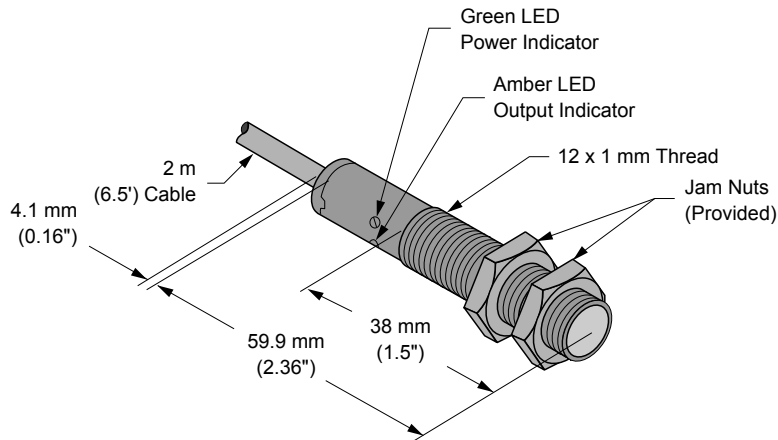
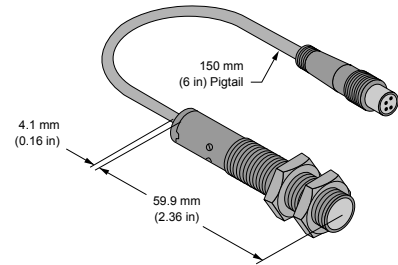

Figure 2. Quick-Disconnect Models



Accessories

Cordsets

4-Pin Snap-on M8 Cordsets—Single Ended					
Model	Length	Style	Dimensions	Pinout (Female)	
PKG4-2	2.03 m (6.66 ft)	Straight			
PKW4Z-2	2 m (6.56 ft)	Right-Angle			1 = Brown 2 = White 3 = Blue 4 = Black

Brackets

SMB12MM

- 12-gauge, stainless steel, right-angle mounting bracket for barrel-style sensors with 12 mm threads
- Curved mounting slot allows the bracket $\pm 10^\circ$ of lateral movement
- Mounting holes accommodate #8 hardware

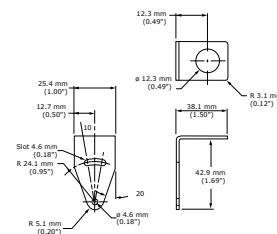

Hole center spacing: A to B = 26.0

Hole size: A = \varnothing 4.6, B = 12.8 x 4.6, C = \varnothing 12.3

Aperture Kits

SP12 sensors may be fitted with apertures that narrow or shape the effective beam of the sensor and protect the sensor's lens. These apertures are rectangular or circular thread-on water-tight parts. Use of apertures with SP12 high-gain sensors makes it possible to create very narrow, concentrated sensing beams for precision sensing applications.

Model	Description	Dimensions
AP12SC	Includes lens, o-ring, thread-on housing, and 3 circular apertures with openings of: <ul style="list-style-type: none"> • 0.5 mm (0.02 inch) diameter • 1.0 mm (0.04 inch) diameter • 2.5 mm (0.10 inch) diameter 	
AP12SR	Includes lens, o-ring, thread-on housing, and 3 rectangular apertures with openings of: <ul style="list-style-type: none"> • 0.5 mm (0.02 inch) wide • 1.0 mm (0.04 inch) wide • 2.5 mm (0.10 inch) wide 	

Banner Engineering Corp Limited Warranty

Banner Engineering Corp. warrants its products to be free from defects in material and workmanship for one year following the date of shipment. Banner Engineering Corp. will repair or replace, free of charge, any product of its manufacture which, at the time it is returned to the factory, is found to have been defective during the warranty period. This warranty does not cover damage or liability for misuse, abuse, or the improper application or installation of the Banner product.

THIS LIMITED WARRANTY IS EXCLUSIVE AND IN LIEU OF ALL OTHER WARRANTIES WHETHER EXPRESS OR IMPLIED (INCLUDING, WITHOUT LIMITATION, ANY WARRANTY OF MERCHANTABILITY OR FITNESS FOR A PARTICULAR PURPOSE), AND WHETHER ARISING UNDER COURSE OF PERFORMANCE, COURSE OF DEALING OR TRADE USAGE.

This Warranty is exclusive and limited to repair or, at the discretion of Banner Engineering Corp., replacement. **IN NO EVENT SHALL BANNER ENGINEERING CORP. BE LIABLE TO BUYER OR ANY OTHER PERSON OR ENTITY FOR ANY EXTRA COSTS, EXPENSES, LOSSES, LOSS OF PROFITS, OR ANY INCIDENTAL, CONSEQUENTIAL OR SPECIAL DAMAGES RESULTING FROM ANY PRODUCT DEFECT OR FROM THE USE OR INABILITY TO USE THE PRODUCT, WHETHER ARISING IN CONTRACT OR WARRANTY, STATUTE, TORT, STRICT LIABILITY, NEGLIGENCE, OR OTHERWISE.**

Banner Engineering Corp. reserves the right to change, modify or improve the design of the product without assuming any obligations or liabilities relating to any product previously manufactured by Banner Engineering Corp. Any misuse, abuse, or improper application or installation of this product or use of the product for personal protection applications when the product is identified as not intended for such purposes will void the product warranty. Any modifications to this product without prior express approval by Banner Engineering Corp will void the product warranties. All specifications published in this document are subject to change; Banner reserves the right to modify product specifications or update documentation at any time. Specifications and product information in English supersede that which is provided in any other language. For the most recent version of any documentation, refer to: www.bannerengineering.com.

For patent information, see www.bannerengineering.com/patents.