



**QUICKSWITCH® PRODUCTS**  
**HIGH-SPEED CMOS**  
**QUICKSWITCH 32-BIT**  
**MULTIWIDTH™ BUS SWITCHES**

**IDTQS34X2245**

**FEATURES:**

- Enhanced N channel FET with no inherent diode to Vcc
- Bidirectional switches connect inputs to outputs
- Zero propagation delay, zero ground bounce
- Internal 25Ω resistors for low noise
- Flow-through pinout for easy layout
- Undershoot clamp diodes on all switch and control inputs
- TTL-compatible control inputs
- Available in 80-pin MilliPaQ™ package

**APPLICATIONS:**

- Hot-swapping, hot-docking
- Voltage translation (5V to 3.3V)
- Bus switching and isolation
- Power conservation
- Logic replacement (data processing)
- Capacitance isolation
- Clock gating

**DESCRIPTION:**

The QS34X2245 is a member of the MultiWidth™ family of QuickSwitch devices and provides a set of 32 high-speed CMOS compatible bus switches in a flow-through pinout. This device is available in the MilliPaQ package, the worlds first small outline 32-bit solution. The low ON-resistance of the QS34X2245 allows inputs to be connected to outputs without adding propagation delay and without generating additional ground bounce noise. Internal 25Ω resistors reduce reflection noise in high-speed applications. When Output Enable (OEn) is low, the switches are turned on, connecting bus A to bus B. When OEn is high, the switches are turned off. This device is ideally suited for 32/64 bit applications where board space is at a premium.

QuickSwitch devices provide speeds an order of magnitude faster than conventional logic devices.

The QS34X2245 is characterized for operation at -40°C to +85°C.

**FUNCTIONAL BLOCK DIAGRAM**

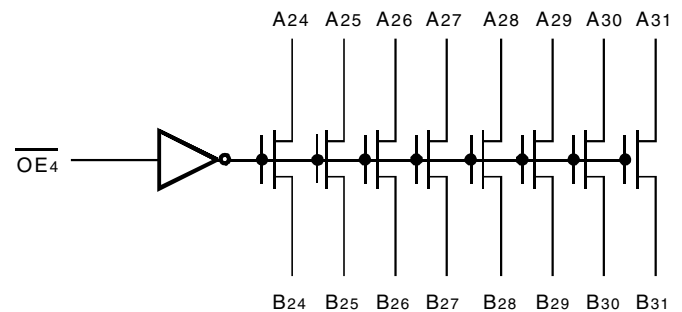
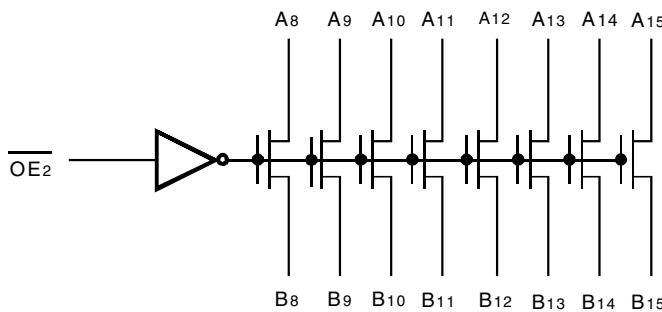
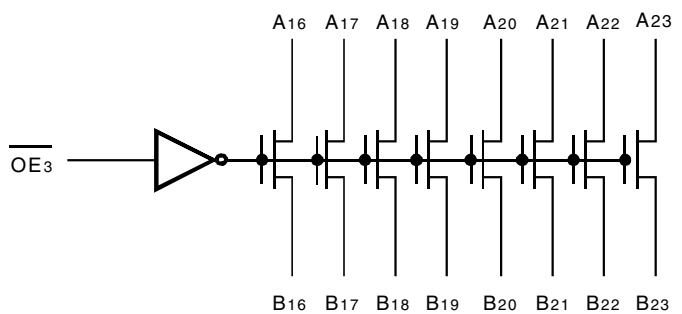
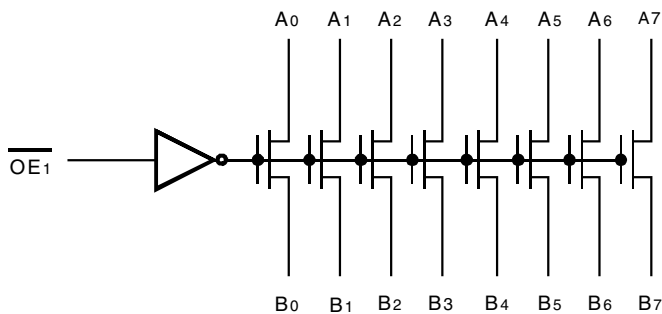

The IDT logo is a registered trademark of Integrated Device Technology, Inc.

## PIN CONFIGURATION

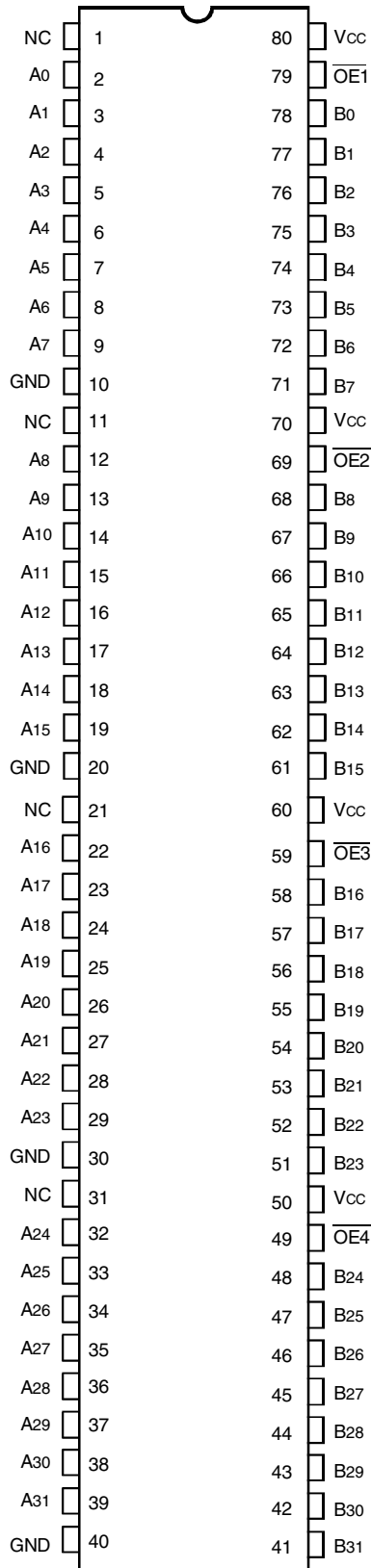

MILLIPAQ  
TOP VIEW

## ABSOLUTE MAXIMUM RATINGS<sup>(1)</sup>

Symbol	Description	Max	Unit
VTERM <sup>(2)</sup>	Supply Voltage to Ground	-0.5 to +7	V
VTERM <sup>(3)</sup>	DC Switch Voltage V <sub>s</sub>	-0.5 to +7	V
VTERM <sup>(3)</sup>	DC Input Voltage V <sub>IN</sub>	-0.5 to +7	V
V <sub>AC</sub>	AC Input Voltage (pulse width ≤ 20ns)	-3	V
I <sub>OUT</sub>	DC Output Current	120	mA
P <sub>MAX</sub>	Maximum Power Dissipation (T <sub>A</sub> = 70°C)	1.4	W
T <sub>STG</sub>	Storage Temperature	-65 to +150	°C

### NOTE:

- Stresses greater than those listed under ABSOLUTE MAXIMUM RATINGS may cause permanent damage to the device. This is a stress rating only and functional operation of the device at these or any other conditions above those indicated in the operational sections of this specification is not implied. Exposure to absolute maximum rating conditions for extended periods may affect reliability.
- V<sub>CC</sub> terminals.
- All terminals except V<sub>CC</sub>.

## CAPACITANCE

(T<sub>A</sub> = +25°C, f = 1.0MHz, V<sub>IN</sub> = 0V, V<sub>OUT</sub> = 0V)

Pins	Typ.	Max. <sup>(1)</sup>	Unit
Control Pins	3	4	pF
Quickswitch Channels (Switch OFF)	7	8	pF

### NOTE:

- This parameter is measured at characterization but not tested.

## PIN DESCRIPTION

Pin Names	Description
$\overline{OEn}$	Output Enable
A <sub>n</sub>	Data I/Os
B <sub>n</sub>	Data I/Os

## FUNCTION TABLE<sup>(1)</sup>

$\overline{OEn}$	Outputs
H	Disconnected
L	A <sub>n</sub> = B <sub>n</sub>

### NOTE:

- H = HIGH Voltage Level  
L = LOW Voltage Level

## DC ELECTRICAL CHARACTERISTICS OVER OPERATING RANGE

Following Conditions Apply Unless Otherwise Specified:

Industrial:  $T_A = -40^{\circ}\text{C}$  to  $+85^{\circ}\text{C}$ ,  $V_{CC} = 5.0\text{V} \pm 5\%$

Symbol	Parameter	Test Conditions	Min.	Typ. <sup>(1)</sup>	Max.	Unit
$V_{IH}$	Input HIGH Level	Guaranteed Logic HIGH for Control Pins	2	—	—	V
$V_{IL}$	Input LOW Level	Guaranteed Logic LOW for Control Pins	—	—	0.8	V
$I_{IN}$	Input Leakage Current (Control Inputs) <sup>(2)</sup>	$0\text{V} \leq V_{IN} \leq V_{CC}$	—	—	$\pm 1$	$\mu\text{A}$
$I_{OZ}$	Off-State Output Current (Hi-Z)	$0\text{V} \leq V_{OUT} \leq V_{CC}$ , Switches OFF	—	—	$\pm 1$	$\mu\text{A}$
$R_{ON}^{(3)}$	Switch ON Resistance	$V_{CC} = \text{Min.}, V_{IN} = 0\text{V}, I_{ON} = 30\text{mA}$	18	23	35	$\Omega$
		$V_{CC} = \text{Min.}, V_{IN} = 2.4\text{V}, I_{ON} = 15\text{mA}$	18	25	40	
$V_P$	Pass Voltage <sup>(2)</sup>	$V_{IN} = V_{CC} = 5\text{V}, I_{OUT} = -5\mu\text{A}$	3.7	4	4.2	V

**NOTES:**

1. Typical values are at  $V_{CC} = 5.0\text{V}$ ,  $T_A = 25^{\circ}\text{C}$ .
2. Pass Voltage is guaranteed but not production tested.
3.  $R_{OUT}$  changed on March 8, 2002. See rear page for more information.

### TYPICAL ON RESISTANCE vs $V_{IN}$ AT $V_{CC} = 5\text{V}$

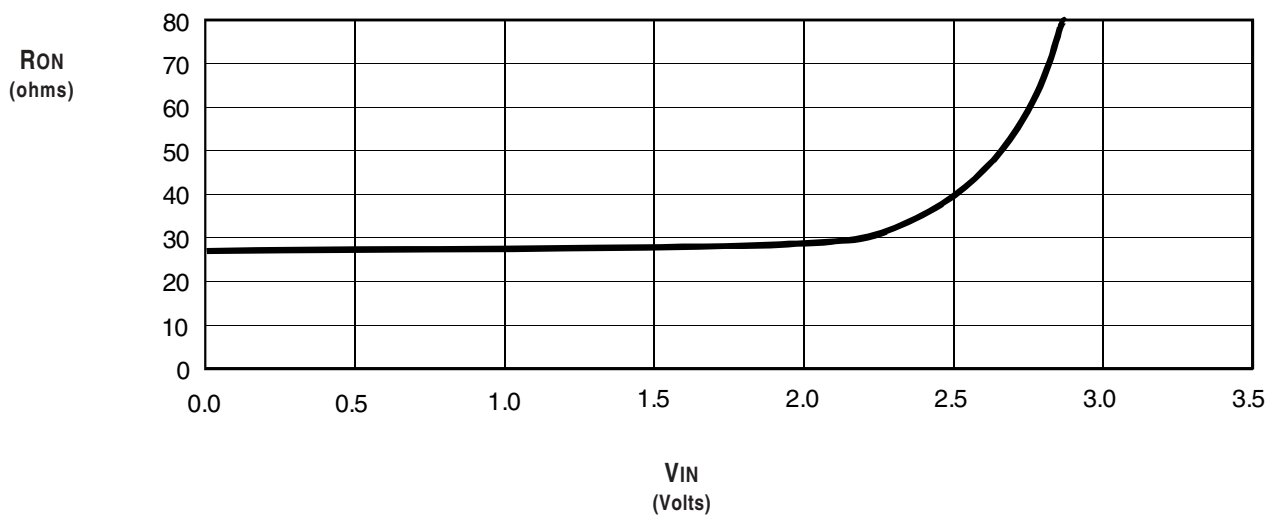

## POWER SUPPLY CHARACTERISTICS

Symbol	Parameter	Test Conditions <sup>(1)</sup>	Max.	Unit
I <sub>CCQ</sub>	Quiescent Power Supply Current	V <sub>CC</sub> = Max., V <sub>IN</sub> = GND or V <sub>CC</sub> , f = 0	12	μA
ΔI <sub>CC</sub>	Power Supply Current per Control Input HIGH <sup>(2)</sup>	V <sub>CC</sub> = Max., V <sub>IN</sub> = 3.4V, f = 0	1.5	mA
I <sub>CCD</sub>	Dynamic Power Supply Current per MHz <sup>(3)</sup>	V <sub>CC</sub> = Max., A and B pins open Control Inputs Toggling at 50% Duty Cycle	0.25	mA/MHz

### NOTES:

- For conditions shown as Min. or Max., use the appropriate values specified under DC Electrical Characteristics.
- Per TLL driven input (V<sub>IN</sub> = 3.4V, control inputs only). A and B pins do not contribute to ΔI<sub>CC</sub>.
- This current applies to the control inputs only and represents the current required to switch internal capacitance at the specified frequency. The A and B inputs generate no significant AC or DC currents as they transition. This parameter is guaranteed but not production tested.

## SWITCHING CHARACTERISTICS OVER OPERATING RANGE

T<sub>A</sub> = -40°C to +85°C, V<sub>CC</sub> = 5.0V ± 5%;

C<sub>LOAD</sub> = 50pF, R<sub>LOAD</sub> = 500Ω unless otherwise noted.

Symbol	Parameter	Min. <sup>(1)</sup>	Typ.	Max.	Unit
t <sub>PLH</sub>	Data Propagation Delay <sup>(1,2)</sup>	—	—	1.25	ns
t <sub>PHL</sub>	An to/from Bn				
t <sub>PZL</sub>	Switch Turn-on Delay	0.5	—	6.6	ns
t <sub>PZH</sub>	$\overline{OE}$ to An/Bn				
t <sub>PLZ</sub>	Switch Turn-off Delay <sup>(1)</sup>	0.5	—	5.2	ns
t <sub>PHZ</sub>	$\overline{OE}$ to An/Bn				

### NOTES:

- Minimums are guaranteed but not production tested.
- The bus switch contributes no propagation delay other than the RC delay of the ON resistance of the switch and the load capacitance. The time constant for the switch alone is of the order of 1.25ns for C<sub>L</sub> = 50pF. Since this time constant is much smaller than the rise and fall times of typical driving signals, it adds very little propagation delay to the system. Propagation delay of the bus switch, when used in a system, is determined by the driving circuit on the driving side of the switch and its interaction with the load on the driven side.

## ORDERING INFORMATION

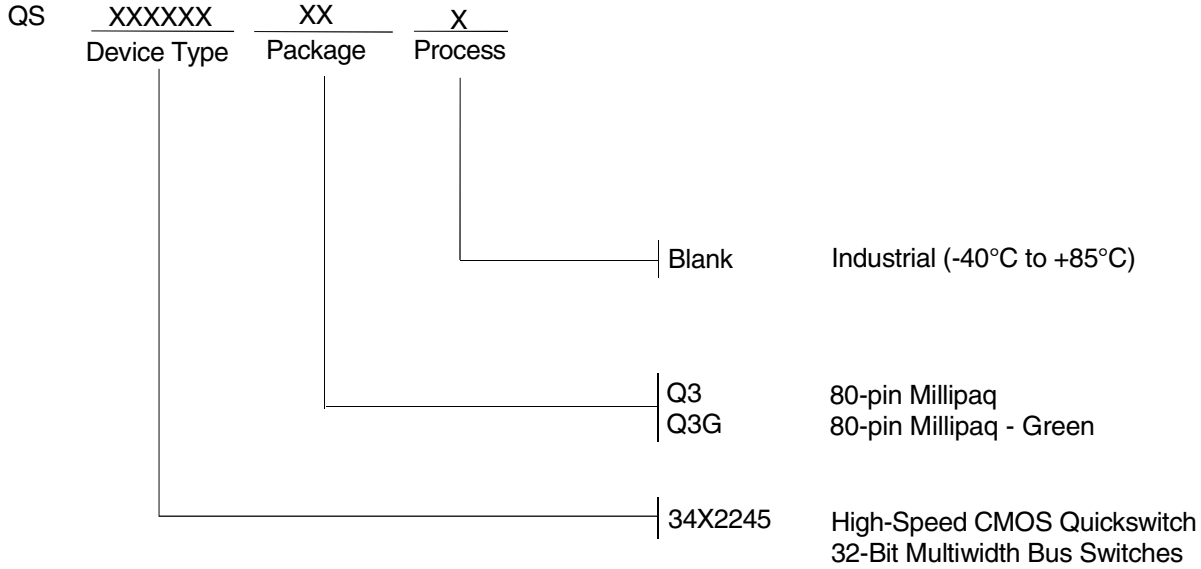

As per PCN L0201-02, the Output Resistance (RON) specifications have changed as of March 8, 2002. The original specifications were:

Parameter	Description	Min.	Typ.	Max.	Unit
RON	VCC = Min, VIN = 0V, ION = 30mA	20	28	40	Ω
	VCC = Min, VIN = 2.4V, ION = 15mA	20	35	48	



**CORPORATE HEADQUARTERS**  
 6024 Silver Creek Valley Road  
 San Jose, CA 95138

**for SALES:**  
 800-345-7015 or 408-284-8200  
 fax: 408-284-2775  
 www.idt.com

**for Tech Support:**  
 logichelp@idt.com