



General Specifications

Motor Protection:

Auto Restart/Polarity Protection

Insulation Resistance:

min 10M Ω by DC500V Megger

Dielectric Withstand Voltage: AC 700V 1s

Allowable Ambient Temperature Range:

-10°C ~ +60°C (Operating)

-40°C ~ +70°C (Storage)

(non-condensing environment)

Expected Life

Failure Rate: 10%

40°C 70,000 Hours

Characteristic Curves

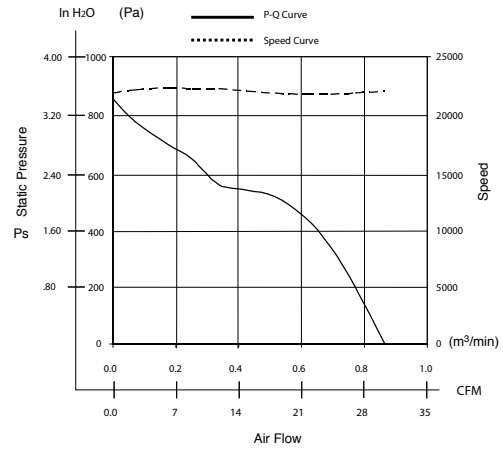

Outline

Units: inch (mm)

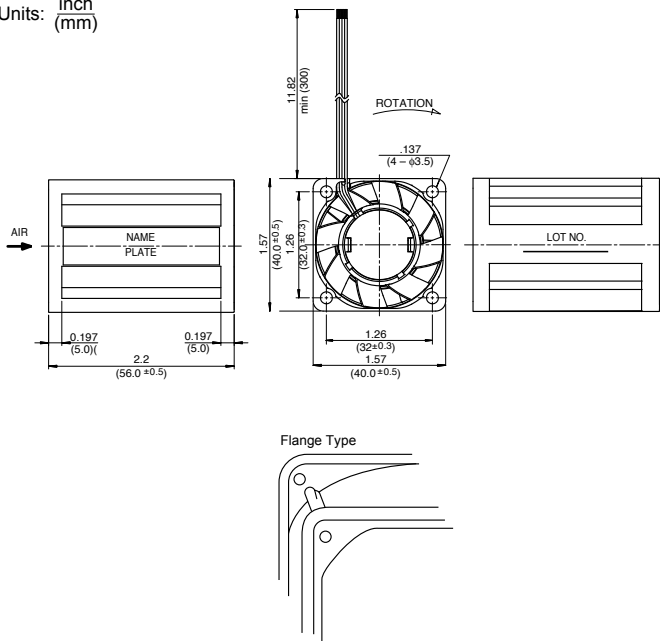

Panel Cut-outs

PATENT PENDING

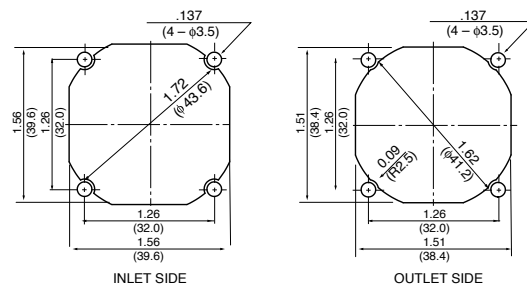

Material

Casing : Plastic (Black) 94V-0

Impeller : Plastic (Black) 94V-0

Bearing : Ball Bearing

Lead Wire : UL10368, AWG24, +Red, -Black

Tach Sig. : White

PWM Control : Brown

Reference PWM Duty vs Speed Curve

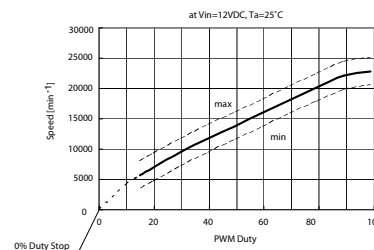

PWM Control Voltage

Vst = 0V ~ 0.5V Stop (On Duty 0%)

Vst = 3.0V ~ 5.0V Full Speed (On Duty 100%)

Vst = Open Full Speed

(At Ta = 25°C, rated voltage 12VDC)

Specifications

MODEL	Product No.	Rated Voltage	Operating Voltage	Current	Input Power	Speed	Max. Air Flow		Max. Static Pressure		Noise	Mass
		(V)	(V)	(A) ^{*1}	(W) ^{*1}	(min ⁻¹) ^{*1}	CFM ^{*1}	(m ³ /min) ^{*1}	in H ₂ O	(Pa) ^{*1}	(dB) ^{*1}	(g)
1622FT-04W-B86-	EXX	12	10.2 ~ 13.2	1.05	12.60	23,000	30.0	0.85	3.54	885.0	60.0	68

Rotation: Clockwise

Airflow Outlet: Air Out Over Struts

*1: Average Values in Free Air