

APPROVED: _____
 DATE: _____ TITLE: _____

Rev	AWO #	Description	Date	Appr
-		RELEASED	11/1/22	
A		UPDATE SPEC.	11/30/22	WX/RC

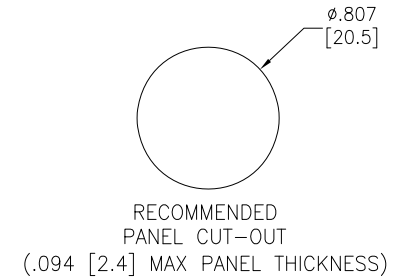
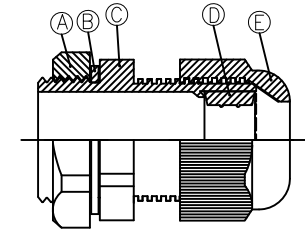
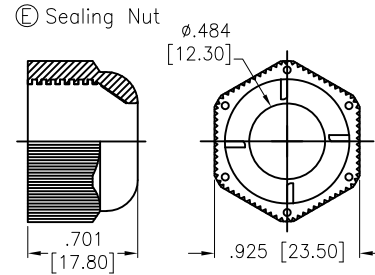
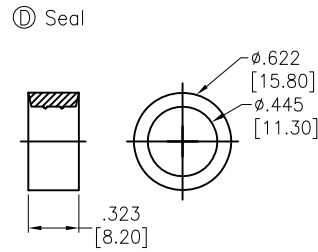
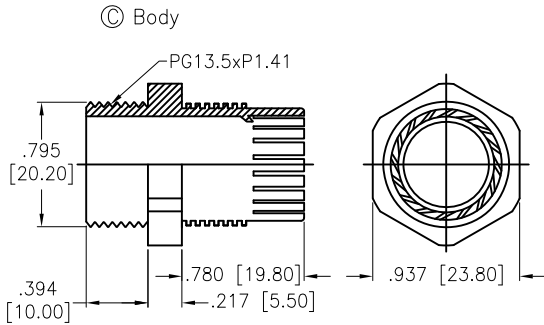
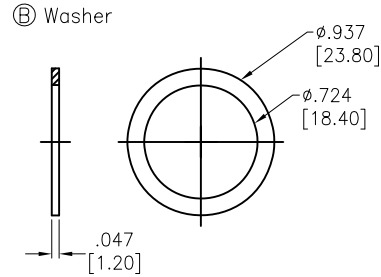
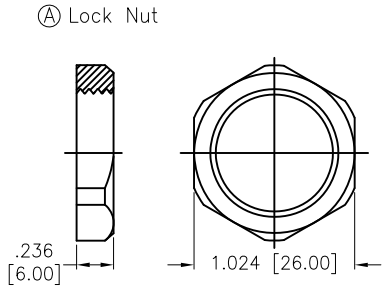

SPECIFICATIONS:

Material:
 Lock Nut: PA66, rated UL 94V-2
 Body: PA66, rated UL 94V-2
 Sealing Nut: PA66, rated UL 94V-2
 Washer: Nitrile Butylene
 Seal: Nitrile Butylene

Mechanical:
 Cable range O.D.: $\phi 0.236 \sim \phi 0.433$ [6.00~11.00mm]
 Nut Torque: 2Nm Max.

Environmental:
 Waterproof: IP68

Lead free, RoHS compliant.



UNLESS OTHERWISE SPECIFIED ALL DIMENSIONS ARE INCHES [MM]. TOLERANCES: EXCEPT AS NOTED		
INCHES	HOLES	
.X ± .10	∅X	± .10
.XX ± .020	∅XX	± .015
.XXX ± .015	∅XXX	± .010
DRAWN	LH	11/1/22
CHECKED	RC	11/1/22
APPROVED		
THIS DRAWING CONTAINS INFORMATION THAT IS PROPRIETARY AND SHOULD NOT BE USED WITHOUT PRIOR WRITTEN PERMISSION FROM ADAM TECH		

ADAM TECH
 909 Rahway Avenue,
 Union, NJ 07083
 Phone: 908-687-5000
 Fax: 908-687-5710

TITLE WATERPROOF CONNECTOR, PG13.5, 1 HOLE, CABLE GLAND, WATERPROOF: IP68		
SIZE X	PART NO. CG-P-13.5	REV. A
REF: S00211C	SCALE: NTS	SHEET 1 OF 1