

4

3

2

1

THIS DRAWING IS UNPUBLISHED. RELEASED FOR PUBLICATION
 © COPYRIGHT - TE Connectivity ALL RIGHTS RESERVED.

REVISIONS					
P	LTR	DESCRIPTION	DATE	DWN	APVD
	O	REL PER 96-1164-005	10JUN96	LO	BB
	A	REVISED PER ECO-17-002887	31AUG2017	RS	DR

D

D

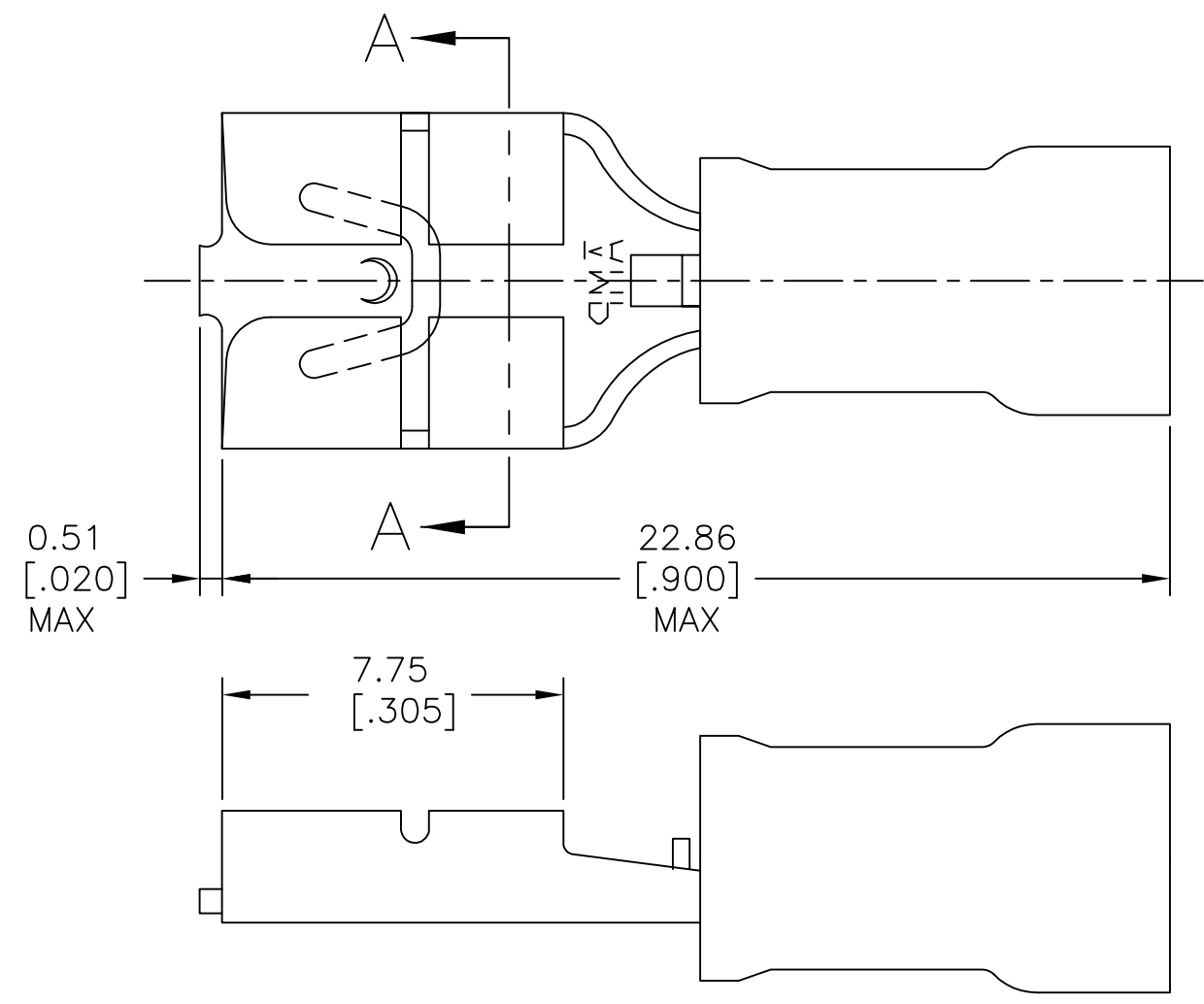

- 1 INSULATION $\phi 3.43$ [$\phi .135$] MAX.
- 2 FITS TAB 0.81 [$.032$] THK.
- △3 MATERIAL:
 BODY : BRASS PER ASTM B36, 0.46 ± 0.05 [$.018 \pm .002$].
 SLEEVE : COPPER PER ASTM B152.
 INSULATION : NYLON PER ASTM D4066.
- △4 FINISH:
 BODY & SLEEVE : TIN PLATE 0.00254 [$.000100$] MIN. EXT. THK PER ASTM B545.

C

C

B

B

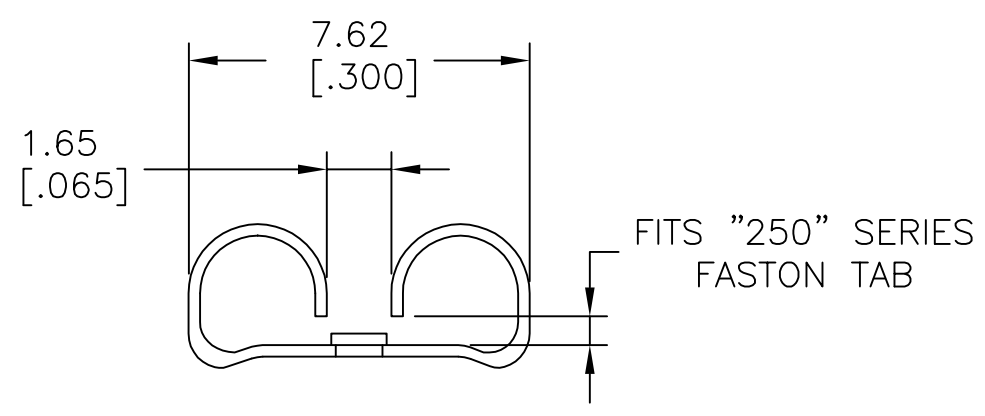

-	LOOSE PIECE	184262-1
QTY	PACKAGE TYPE	PART NO

A

A

AMP INCORPORATED CUSTOMER SERVICE SYSTEM		MAX RECOMMENDED OPERATING TEMPERATURE: -	THIS DRAWING IS A CONTROLLED DOCUMENT.		DWN L OLMEDA 29MAY96	TE Connectivity RECEPTACLE, 250 SERIES, LOW INSERTION FORCE, FASTON™, PIDG™, WIRE SIZE, 22-18 AWG							
FOR ADDITIONAL PRODUCT INFORMATION OR COPIES OF DRAWINGS AND TECHNICAL DOCUMENTS	PRODUCT INFORMATION CENTER 1-800-522-6752	VOLTAGE RATING: -	DIMENSIONS: mm [INCHES]	TOLERANCES UNLESS OTHERWISE SPECIFIED: 0 PLC ± - 1 PLC ± - 2 PLC ± 0.38 [.015] 3 PLC ± - 4 PLC ± - ANGLES ± -	CHK M ELLIS 29MAY96					APVD B BARE 29MAY96	NAME	SIZE	CAGE CODE
FOR APPLICATION TOOLING INFORMATION	TOOLING ASSISTANCE CENTER 1-800-722-1111	CIRCULAR MIL AREA: -			APPLICATION SPEC 114-1002	WEIGHT -	A3	00779	C=184262	-	SCALE 6:1	SHEET 1 OF 1	REV A
FOR ORDER ENTRY	1-800-526-5142		MATERIAL △3	FINISH △4	CUSTOMER DRAWING								