

REV.	DESCRIPTION	DATE	APPROVED
D	Engineering Update w / PPA Version Added	04/18/05	M. C.
E	Engineering Update w / -2 Version Added	08/16/05	M. C.
F	Updated Part No. Table	04/11/06	M. C.
G	Obsolete H-17XC-1 Holder	09/27/07	M. C.
H	Removed Material Code	05/28/16	J. C.

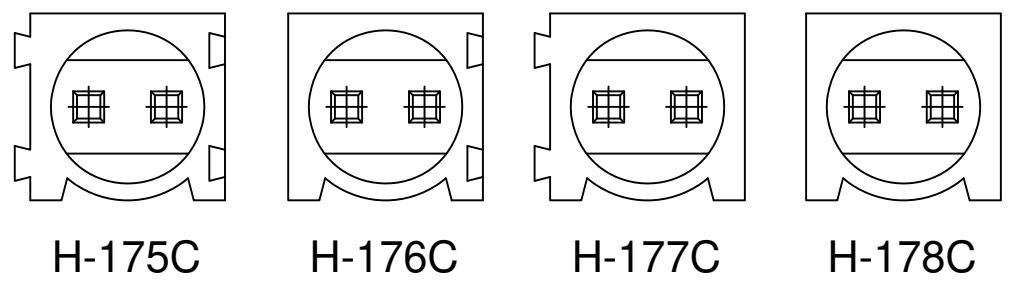
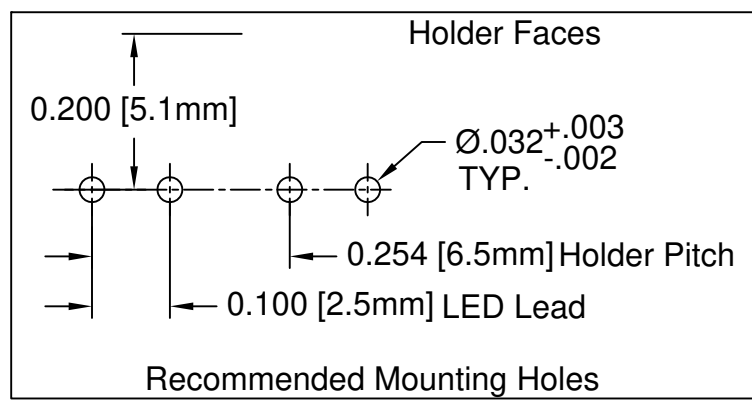
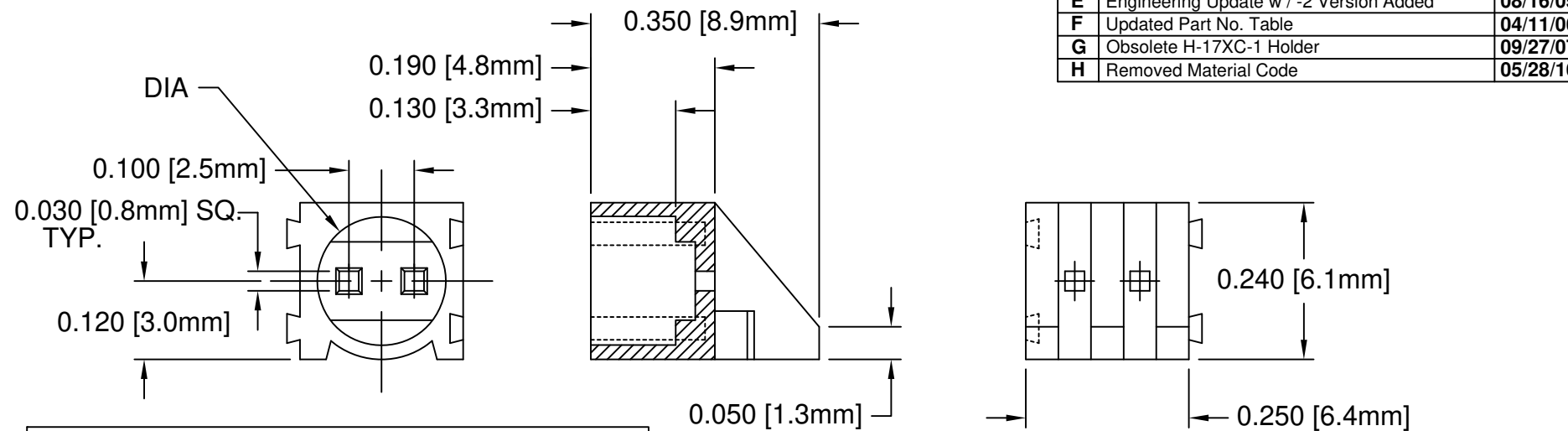

PART NO.				DIA
H-175C SERIES	H-176C SERIES	H-177C SERIES	H-178C SERIES	
H-175C	H-176C	H-177C	H-178C	.197 [5.0mm]
H-175C-2	H-176C-2	H-177C-2	H-178C-2	.206 [5.2mm] +/- 0.002"

- 2. MATERIAL: NYLON 6/6, 94V-0, BLACK.
- 1. GENERAL SPECIFICATIONS: BIVAR MOLDED COMPONENT SPECIFICATION BV00-E101.

STANDARD TOLERANCE (UNLESS OTHERWISE SPECIFIED)		 4 THOMAS, IRVINE, CA. 92618 TEL: (949) 951-8808 FAX: (949) 951-3974	
DECIMALS	ANGULAR		
.X ± .1	X° ± 1°	 TITLE: T-1¼ (5mm) LED HOLDER INTERLOCKING VARIABLE DIAMETER	
.XX ± .01			
.XXX ± .005			
DESIGNED: D. Green	DATE: 04/18/03	PART NO: H-17XC-X	REVISION: H
CHECKED: M. Chen	DATE: 04/18/03	CAGE CODE : 32559	SHEET # 1 OF 1
CAD GENERATED DOCUMENT. DO NOT MEASURE DRAWING.			