



SPECIFICATION FOR APPROVAL

CRYSTAL UNIT

Features

Frequency range :

External dimensions (mm)

L : 3.2 x W : 2.5 x H : 0.8



Electrical Characteristics

NO.	Parameters		Specifications	Notes
1	Nominal frequency	F0	8.000~52.000MHz	Or customizable
2	Mode of Oscillation	-	Fundamental	AT-CUT
3	Load Capacitance	CL	4~25pF	Or customizable
4	Frequency Tolerance	FL	± 10ppm	Or customizable
5	Frequency Stability	TC	± 30ppm	Or customizable
6	Operating Temperature	-	-40℃~+85℃	Or customizable
7	Drive Level	DL	100uW	Or customizable
8	Effective Resistance	RR	40Ω	Or customizable
9	Shunt Capacitance	C0	≤3.0pF	
10	Insulation Resistance	IR	≥500M Ω	at DC 100V
11	Spurious Ratio	SPDB	≤-3dB	F0±500KHz
12	Aging	-	± 3ppm	Or customizable
13	Storage Temperature Range	-	-55~+125℃	

★Note: If you need customization, please communicate with us.

Ordering Information

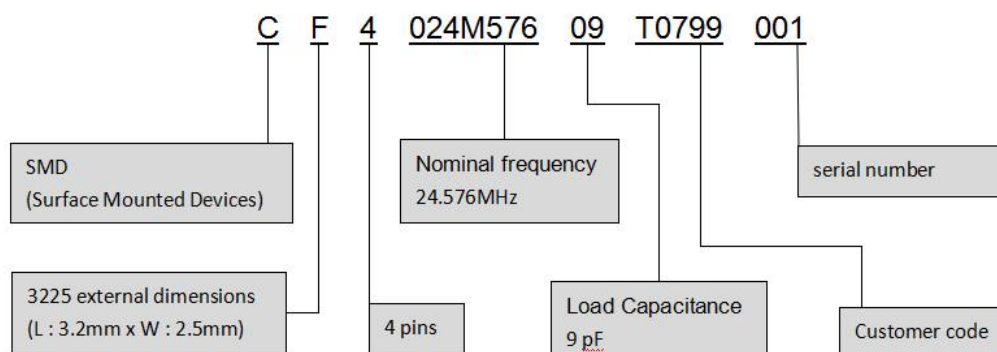

地址：安徽省合肥市经开区云谷路 2569 号

ADD: No. 2569 YunGu Road, HeFei Economy & Technology Development District

Mail: chehangyuan@hfjwt.cn

http: //www. hfjwt. cn



SPECIFICATION FOR APPROVAL

CRYSTAL UNIT

Dimensions

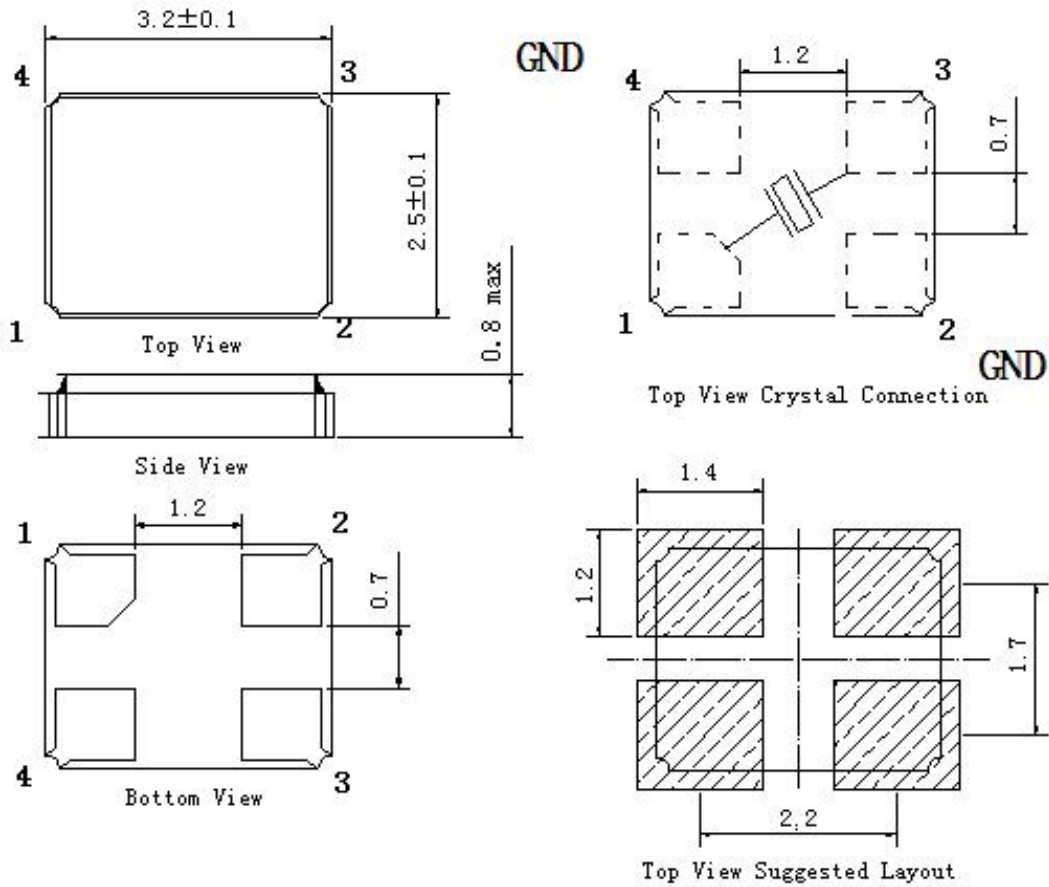

Marking

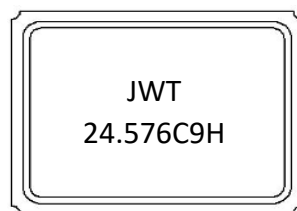

- JWT ----- Logo
- 24.576 ----- Frequency
- C9 ----- Load Capacitance
- H ----- High Temperature

地址：安徽省合肥市经开区云谷路 2569 号

ADD: No. 2569 YunGu Road, HeFei Economy & Technology Development District

Mail: chehangyuan@hfjwt.cn

http: //www. hfjwt. cn

Reflow Profile

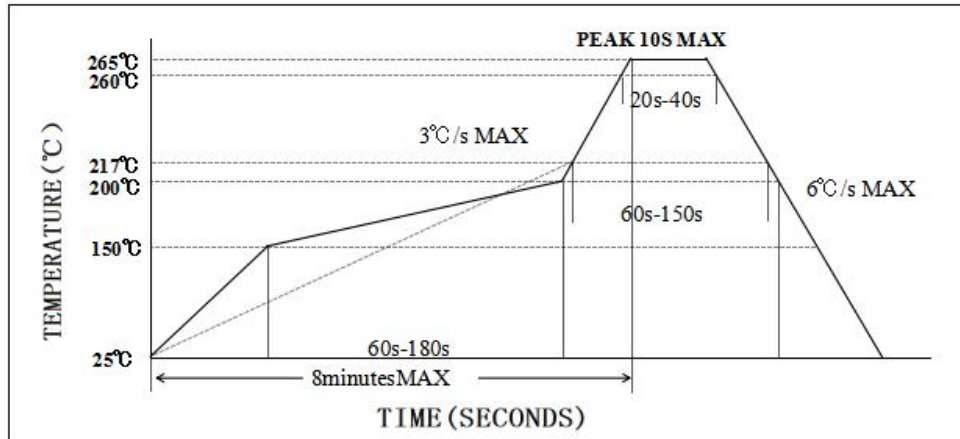

Reference standard: JEDEC J-STD-020. (lead free)

Dimension of taping and reel

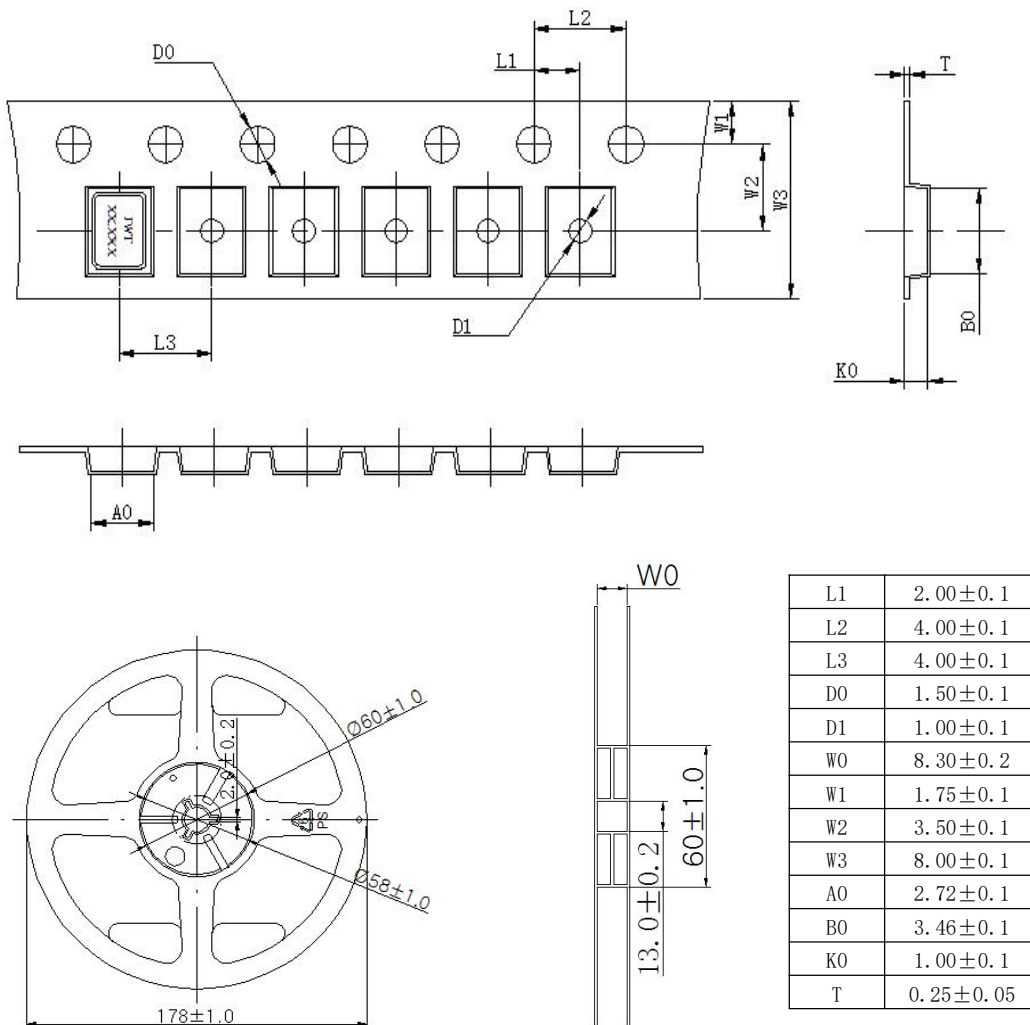

地址：安徽省合肥市经开区云谷路 2569 号

ADD: No. 2569 YunGu Road, HeFei Economy & Technology Development District

Mail: chehangyuan@hfjwt.cn

http: //www. hfjwt. cn