

CLF1G0060-10; CLF1G0060S-10

Broadband RF power GaN HEMT

Rev. 2 — 29 January 2013

Objective data sheet

1. Product profile

1.1 General description

The CLF1G0060-10 and CLF1G0060S-10 are 10 W general purpose broadband GaN HEMTs usable from DC to 6.0 GHz.

Table 1. CW and pulsed RF application information

Typical RF performance at $T_{case} = 25\text{ }^{\circ}\text{C}$; $I_{DQ} = 40\text{ mA}$; $V_{DS} = 50\text{ V}$ in a class-AB broadband demo board.

Test signal	f (MHz)	P _L (W)	G _p (dB)	η _D (%)
1-Tone CW	200	10	17.7	42.6
	500	10	16.7	46.6
	1000	10	15	38.7
	1500	10	14.3	32.6
	2000	10	14.2	32.6
1-Tone pulsed [1]	200	10	18.8	44
	500	10	17.8	48.2
	1000	10	16.8	39
	1500	10	16.7	33.9
	2000	10	17	33.2

[1] Pulsed RF; $t_p = 15\text{ }\mu\text{s}$; $\delta = 10\text{ }\%$.

Table 2. 2-Tone CW application information

Typical 2-Tone performance at $T_{case} = 25\text{ }^{\circ}\text{C}$; $I_{DQ} = 40\text{ mA}$; $V_{DS} = 50\text{ V}$ in a class-AB broadband demo board.

Test signal	f (MHz)	P _{L(PEP)} (W)	IMD3 (dBc)
2-Tone CW [1]	500	5	-47.4
	1000	5	-48.7
	1500	5	-44.7
	2000	5	-39.2
	2500	5	-40.4

[1] 2-Tone CW; $\Delta f = 1\text{ MHz}$.



1.2 Features and benefits

- Frequency of operation is from DC to 6.0 GHz
- 10 W general purpose broadband RF Power GaN HEMT
- Excellent ruggedness (VSWR = 10 : 1)
- High voltage operation (50 V)
- Thermally enhanced package

1.3 Applications

- Commercial wireless infrastructure (cellular, WiMAX)
- Radar
- Broadband general purpose amplifier
- Public mobile radios
- Industrial, scientific, medical
- Jammers
- EMC testing
- Defense application

2. Pinning information

Table 3. Pinning

Pin	Description	Simplified outline	Graphic symbol
CLF1G0060-10 (SOT1227A)			
1	drain		
2	gate		
3	source		
CLF1G0060S-10 (SOT1227B)			
1	drain		
2	gate		
3	source		

[1] Connected to flange.

3. Ordering information

Table 4. Ordering information

Type number	Package		Version
	Name	Description	
CLF1G0060-10	-	flanged ceramic package; 2 mounting holes; 2 leads	SOT1227A
CLF1G0060S-10	-	earless flanged ceramic package; 2 leads	SOT1227B

4. Limiting values

Table 5. Limiting values

In accordance with the Absolute Maximum Rating System (IEC 60134).

Symbol	Parameter	Conditions	Min	Max	Unit
V_{DS}	drain-source voltage		-	150	V
V_{GS}	gate-source voltage		-8	+3	V
I_{GF}	forward gate current	external $R_G = 5 \Omega$	-	3.7	mA
T_{stg}	storage temperature		-65	+150	°C
T_j	junction temperature	measured via IR scan	-	250	°C

5. Thermal characteristics

Table 6. Thermal characteristics

Symbol	Parameter	Conditions	Typ	Unit
$R_{th(j-c)}$	thermal resistance from junction to case	$T_j = 200 \text{ °C}$	[1] <td>	K/W

[1] T_j is measured via IR scan with case temperature of 85 °C and power dissipation of <td> W.

6. Characteristics

Table 7. DC Characteristics

$T_{case} = 25 \text{ °C}$; unless otherwise specified.

Symbol	Parameter	Conditions	Min	Typ	Max	Unit
$V_{(BR)DSS}$	drain-source breakdown voltage	$V_{GS} = -7 \text{ V}$; $I_{DS} = 2.4 \text{ mA}$	150	-	-	V
$V_{GS(th)}$	gate-source threshold voltage	$V_{DS} = 0.1 \text{ V}$; $I_{DS} = 2.4 \text{ mA}$	-2.4	-2	-1.6	V
I_{DSX}	drain cut-off current	$V_{DS} = 10 \text{ V}$; $V_{GS} = 3 \text{ V}$	-	1.7	-	A
g_{fs}	forward transconductance	$V_{DS} = 10 \text{ V}$; $V_{GS} = 0 \text{ V}$	-	0.38	-	S

Table 8. RF Characteristics

Test signal: pulsed RF; $t_p = 100 \mu\text{s}$; $\delta = 10 \%$; RF performance at $V_{DS} = 50 \text{ V}$; $I_{Dq} = 50 \text{ mA}$;
 $T_{case} = 25 \text{ °C}$; unless otherwise specified in a class-AB production circuit.

Symbol	Parameter	Conditions	Min	Typ	Max	Unit
f	frequency		3	-	3.5	GHz
η_D	drain efficiency	$P_L = 10 \text{ W}$	-	49.5	-	%
G_p	power gain	$P_L = 10 \text{ W}$	-	14.5	-	dB
RL_{in}	input return loss	$P_L = 10 \text{ W}$	-	-8.5	-	dB
$P_{droop(pulse)}$	pulse droop power	$P_L = 10 \text{ W}$	-	0.04	-	dB
t_r	rise time	$P_L = 10 \text{ W}$	-	5	-	ns
t_f	fall time	$P_L = 10 \text{ W}$	-	5	-	ns

7. Application information

7.1 Demo circuit

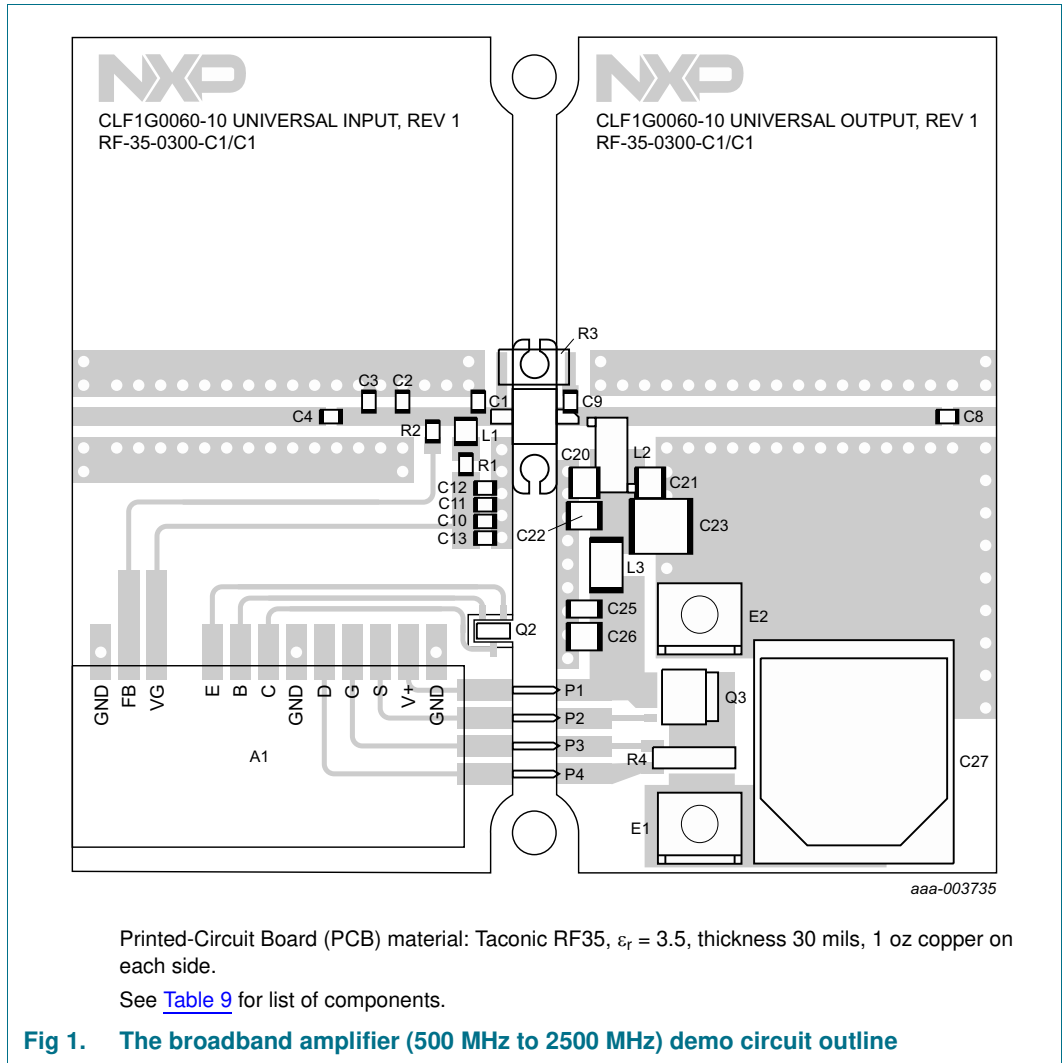

Table 9. List of components

See [Figure 1](#).

Component	Description	Value	Remarks
A1	GaN bias module v2	-	NXP
C1	multilayer ceramic chip capacitor	3.9 pF	ATC 600F
C2	multilayer ceramic chip capacitor	3.0 pF	ATC 600F
C3	multilayer ceramic chip capacitor	1.2 pF	ATC 600F
C4, C8	multilayer ceramic chip capacitor	33 pF	ATC 600F
C9	multilayer ceramic chip capacitor	10 pF	ATC 600F
C10	electrolytic capacitor	10 nF, 50 V	SMD 0805
C11	electrolytic capacitor	22 nF, 100 V	SMD 0805
C12	electrolytic capacitor	1 nF, 100 V	SMD 0805

Table 9. List of components ...continued
See [Figure 1](#).

Component	Description	Value	Remarks
C13	electrolytic capacitor	100 nF, 50 V	SMD 0805
C20	multilayer ceramic chip capacitor	1 nF	ATC 700B
C21	multilayer ceramic chip capacitor	100 pF	ATC 700B
C22, C26	electrolytic capacitor	10 nF, 200 V	SMD 1210
C23	electrolytic capacitor	10 μ F, 100 V	SMD 2220
C25	electrolytic capacitor	1 μ F, 100 V	SMD 1206
C27	electrolytic capacitor	470 μ F, 63 V	Panasonic EEE-TK1J471AM
E1, E2	drain voltage connection	-	
J1	RF in connector	-	
J2	RF out connector	-	
L1	inductor	100 nH	Coilcraft 0805CS-101XJL
L2	inductor	28 nH	Coilcraft B08TJL
L3	ferrite bead	5 A	Fair-Rite 2743019447
P1, P2, P3, P4	1 row, 4-way vertical DC connector header	-	
Q1	transistor	-	CLF1G0060-10
Q2	transistor	-	NXP BC857B
Q3	transistor	-	NXP PSMN8R2-80YS
R1	resistor	10.0 Ω	Generic
R2	resistor	10.0 k Ω	Generic
R3	resistor	550 Ω	Generic
R4	resistor	0.01 Ω	Susumu RL7520WT-R010-F

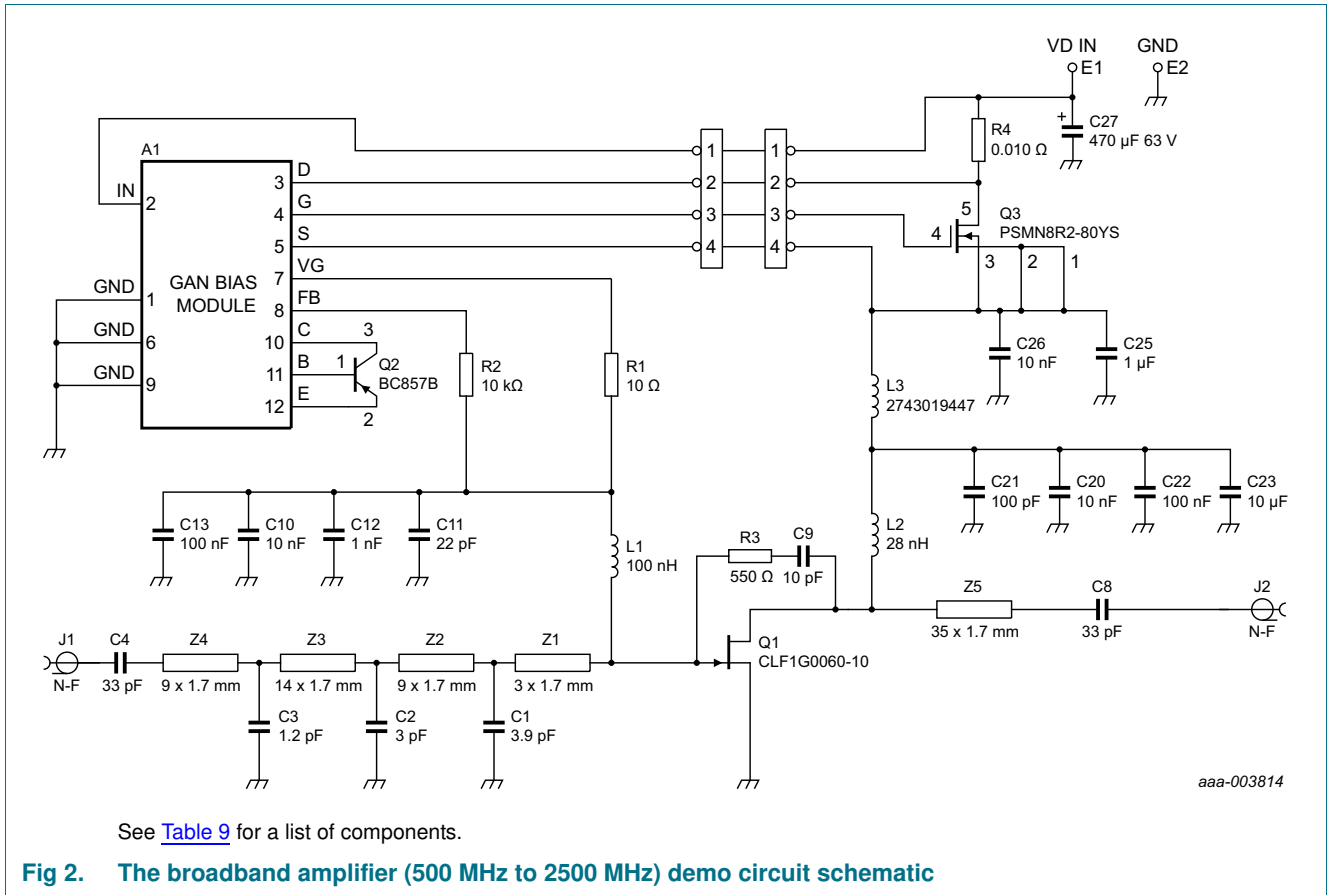

7.2 Application test results

Table 10. CW and pulsed RF application information

Typical RF performance at $T_{case} = 25\text{ }^{\circ}\text{C}$; $I_{DQ} = 40\text{ mA}$; $V_{DS} = 50\text{ V}$ in a class-AB broadband demo board.

Test signal	f (MHz)	P _L (W)	G _p (dB)	η _D (%)
1-Tone CW	200	10	17.7	42.6
	500	10	16.7	46.6
	1000	10	15	38.7
	1500	10	14.3	32.6
	2000	10	14.2	32.6
1-Tone pulsed [1]	200	10	18.8	44
	500	10	17.8	48.2
	1000	10	16.8	39
	1500	10	16.7	33.9
	2000	10	17	33.2

[1] Pulsed RF; $t_p = 15\text{ }\mu\text{s}$; $\delta = 10\text{ }\%$.

Table 11. 2-Tone CW application information

Typical 2-Tone performance at $T_{case} = 25\text{ }^{\circ}\text{C}$; $I_{Dq} = 40\text{ mA}$; $V_{DS} = 50\text{ V}$ in a class-AB broadband demo board.

Test signal	f (MHz)	$P_{L(PEP)}$ (W)	IMD3 (dBc)
2-Tone CW [1]	500	5	-47.4
	1000	5	-48.7
	1500	5	-44.7
	2000	5	-39.2
	2500	5	-40.4

[1] 2-Tone CW; $\Delta f = 1\text{ MHz}$.

7.3 Graphical data

The following figures are measured in a broadband amplifier demo board from 500 MHz to 2500 MHz.

7.3.1 1-Tone CW RF performance

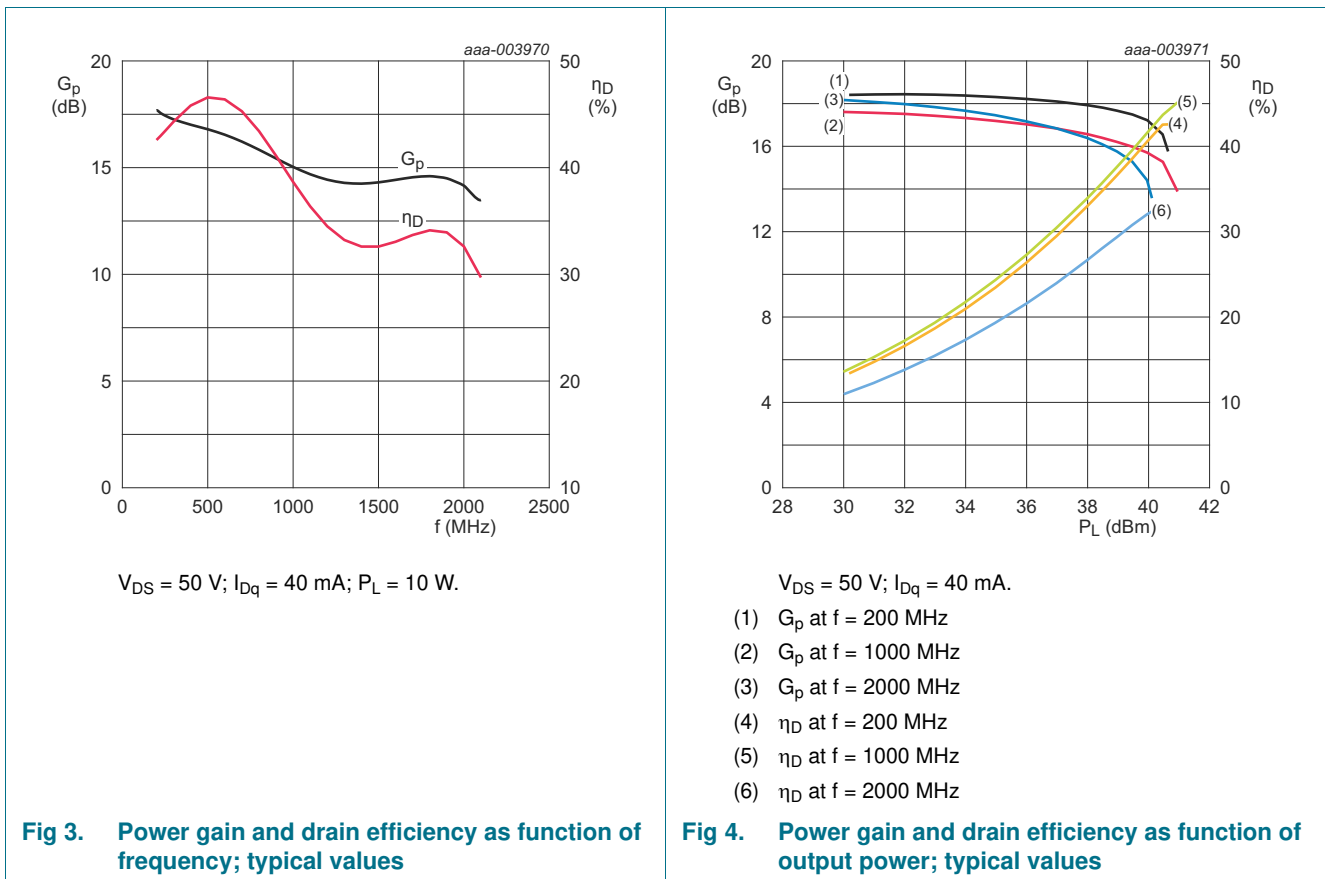

7.3.2 1-Tone pulsed RF performance

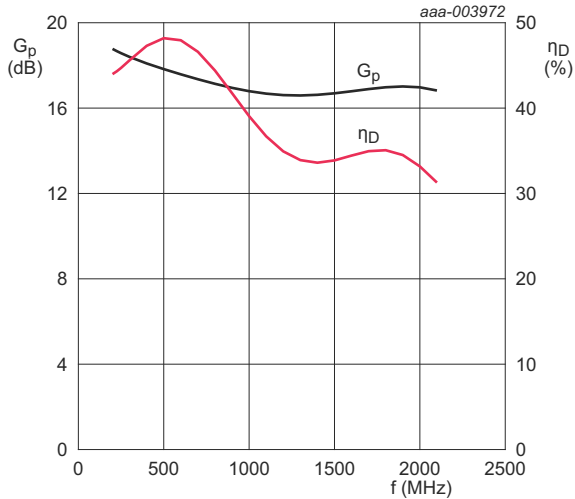

$V_{DS} = 50\text{ V}$; $I_{Dq} = 40\text{ mA}$; $P_L = 10\text{ W}$; $t_p = 15\text{ }\mu\text{s}$; $\delta = 1\text{ }\%$.

Fig 5. Power gain and drain efficiency as function of frequency; typical values

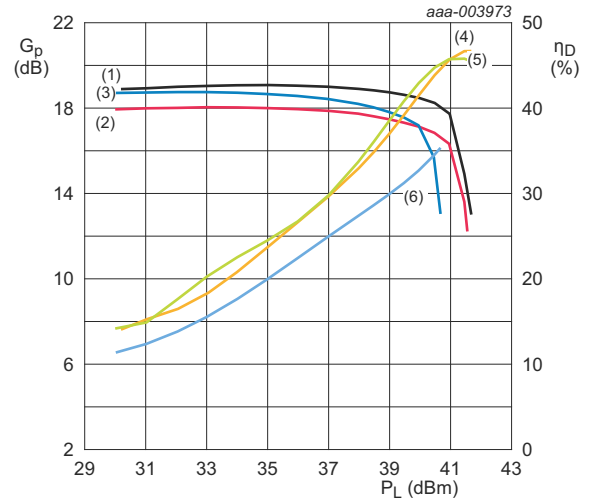

$V_{DS} = 50\text{ V}$; $I_{Dq} = 40\text{ mA}$; $t_p = 15\text{ }\mu\text{s}$; $\delta = 1\text{ }\%$.

- (1) G_p at $f = 200\text{ MHz}$
- (2) G_p at $f = 1000\text{ MHz}$
- (3) G_p at $f = 2000\text{ MHz}$
- (4) η_D at $f = 200\text{ MHz}$
- (5) η_D at $f = 1000\text{ MHz}$
- (6) η_D at $f = 2000\text{ MHz}$

Fig 6. Power gain and drain efficiency gain as function of output power; typical values

7.3.3 2-Tone CW performance

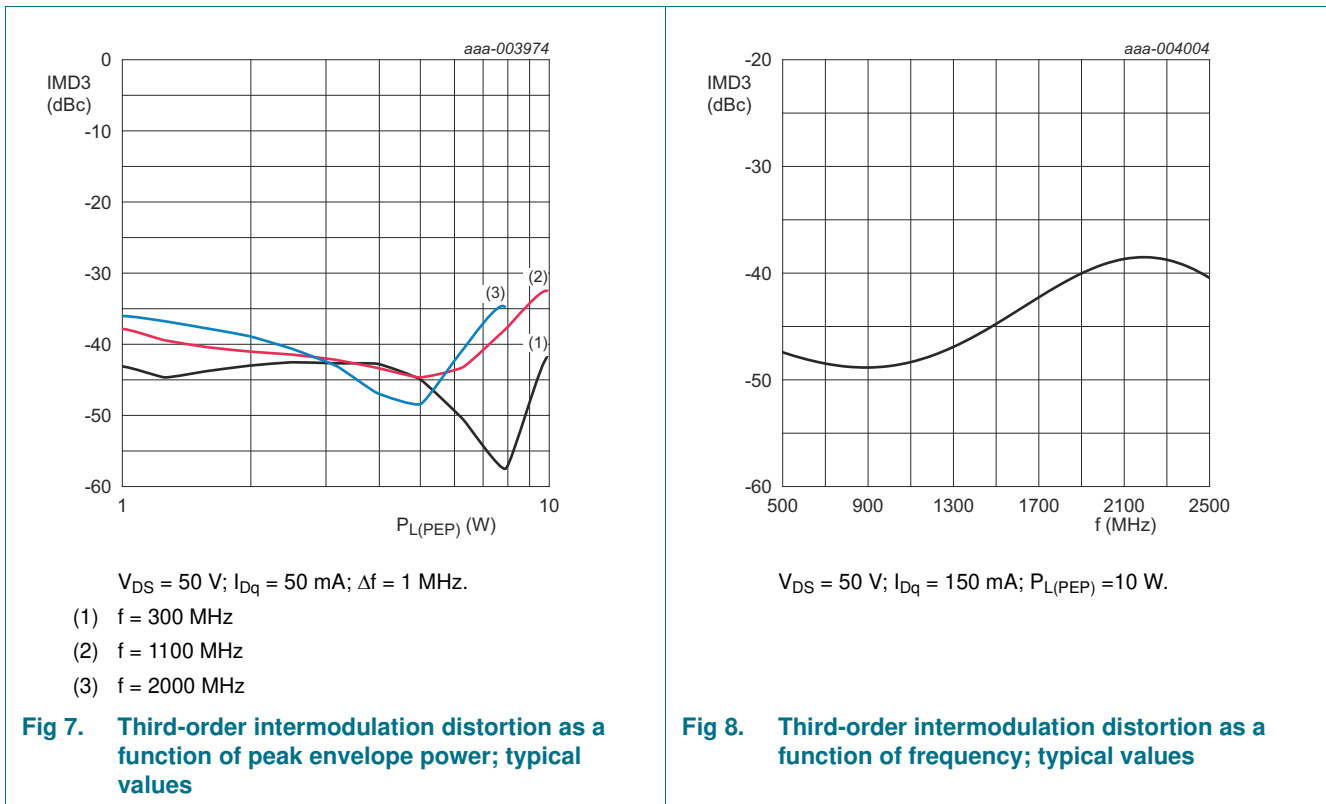

7.3.4 Bias module

The bias module information for the GaN HEMT amplifier is described in application note “AN11130”.

8. Test information

8.1 Ruggedness in class-AB operation

The CLF1G0060-10 and CLF1G0060S-10 are capable of withstanding a load mismatch corresponding to $V_{SWR} = 10 : 1$ through all phases under the following conditions: $V_{DS} = 50\text{ V}$; $P_L = 10\text{ W}$ (pulsed RF), $f = <td>\text{ MHz}$.

8.2 Load pull impedance information

The measured load pull impedances are shown below. Impedance reference plane defined at device leads. Measurements performed with NXP test fixtures. Test temperature set at $25\text{ }^\circ\text{C}$ with a pulsed CW signal; $t_p = 100\text{ }\mu\text{s}$; $\delta = 10\text{ }\%$; RF performance at $V_{DS} = 50\text{ V}$; $I_{Dq} = 20\text{ mA}$.

Table 12. Typical impedance
Typical values unless otherwise specified.

f MHz	Z _S Ω	Z _L (maximum P _{L(M)}) Ω	Z _L (maximum η _D) Ω
2500	4.7 – 3.8j	23.1 + 22.6j	12 + 28.4j
2700	4.5 – 6.3j	19.5 + 22.2j	9.1 + 25.1j
3300	6.6 – 14j	14 + 13.5j	7.9 + 18.6j
3500	6.5 – 18j	12.7 + 14.7j	7.5 + 15.6j
3700	8.1 – 22j	12.7 + 14.7j	6.7 + 14.6j
4000	8.3 – 32j	9.5 + 13.8j	6.5 + 13.8j

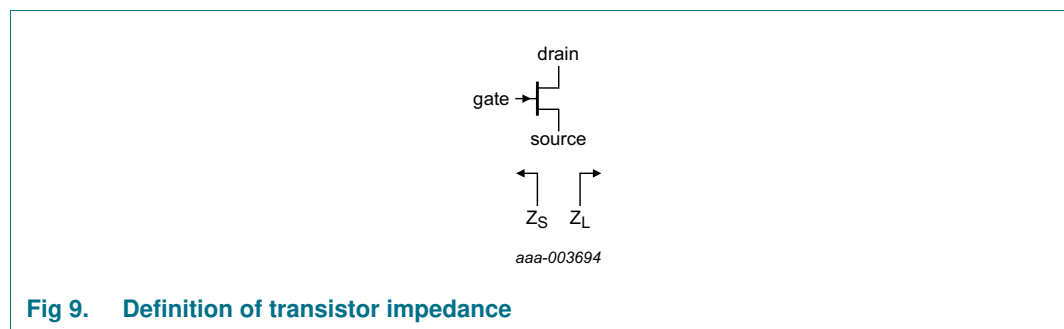

Fig 9. Definition of transistor impedance

Z_S is the measured source pull impedance presented to the device. Z_L is the measured load pull impedance presented to the device.

8.3 Packaged S-parameter data

Table 13. S-parameter

Small signal; $V_{DS} = 50\text{ V}$; $I_{DQ} = 20\text{ mA}$; $Z_S = Z_L = 50\ \Omega$

f (MHz)	S ₁₁		S ₂₁		S ₁₂		S ₂₂	
	Magnitude (ratio)	Angle (degree)	Magnitude (ratio)	Angle (degree)	Magnitude (ratio)	Angle (degree)	Magnitude (ratio)	Angle (degree)
100	0.99129	-23.269	21.314	164.59	0.0071276	75.423	0.95962	-10.001
200	0.96902	-44.968	19.981	150.22	0.013329	61.893	0.92382	-19.186
300	0.94116	-64.133	18.221	137.49	0.018152	50.009	0.87835	-27.146
400	0.91414	-80.511	16.383	126.5	0.021627	39.869	0.83352	-33.905
500	0.89101	-94.309	14.666	117.04	0.024008	31.278	0.79464	-39.708
600	0.87242	-105.92	13.145	108.84	0.025571	23.957	0.76322	-44.832
700	0.85792	-115.75	11.832	101.62	0.026538	17.641	0.73885	-49.499
800	0.84676	-124.16	10.706	95.167	0.027071	12.118	0.72048	-53.868
900	0.83822	-131.44	9.7421	89.316	0.027281	7.2229	0.70698	-58.039
1000	0.8317	-137.82	8.9136	83.937	0.027246	2.8351	0.69734	-62.075
1100	0.82673	-143.48	8.1977	78.936	0.027018	-1.1346	0.69074	-66.012
1200	0.82294	-148.57	7.5751	74.24	0.026636	-4.751	0.68654	-69.873
1300	0.82008	-153.2	7.0302	69.796	0.026128	-8.0607	0.68423	-73.666
1400	0.81793	-157.44	6.5504	65.559	0.025514	-11.096	0.6834	-77.399
1500	0.81633	-161.37	6.1253	61.499	0.024809	-13.878	0.68374	-81.073
1600	0.81517	-165.04	5.7467	57.588	0.024028	-16.42	0.68499	-84.69
1700	0.81435	-168.5	5.4078	53.806	0.023179	-18.725	0.68697	-88.25
1800	0.81379	-171.78	5.103	50.136	0.022272	-20.79	0.68951	-91.753
1900	0.81344	-174.91	4.8277	46.564	0.021316	-22.605	0.69248	-95.199
2000	0.81325	-177.92	4.5781	43.078	0.020316	-24.15	0.69577	-98.59
2100	0.81317	179.17	4.351	39.668	0.019282	-25.396	0.6993	-101.92
2200	0.81318	176.35	4.1437	36.326	0.018222	-26.304	0.70298	-105.21
2300	0.81325	173.6	3.954	33.045	0.017143	-26.82	0.70677	-108.43
2400	0.81336	170.91	3.7798	29.818	0.016058	-26.873	0.71061	-111.61
2500	0.8135	168.27	3.6196	26.639	0.014978	-26.372	0.71447	-114.74
2600	0.81364	165.66	3.4718	23.502	0.013923	-25.202	0.7183	-117.83
2700	0.81378	163.09	3.3353	20.404	0.012912	-23.223	0.72209	-120.87
2800	0.8139	160.54	3.2089	17.34	0.011978	-20.279	0.72581	-123.87
2900	0.81401	158	3.0917	14.305	0.011158	-16.219	0.72943	-126.83
3000	0.81409	155.48	2.9828	11.296	0.0105	-10.954	0.73296	-129.76
3100	0.81414	152.96	2.8815	8.3092	0.010059	-4.5429	0.73637	-132.66
3200	0.81416	150.44	2.7871	5.341	0.00989	2.7229	0.73966	-135.53
3300	0.81415	147.91	2.6991	2.3882	0.010031	10.309	0.74282	-138.37
3400	0.8141	145.38	2.6169	-0.5524	0.010495	17.578	0.74585	-141.19
3500	0.81402	142.83	2.5399	-3.4839	0.011266	23.999	0.74874	-144
3600	0.81392	140.27	2.4679	-6.4092	0.012313	29.286	0.75149	-146.78
3700	0.81378	137.69	2.4004	-9.3313	0.013594	33.387	0.7541	-149.56

Table 13. S-parameter ...continued
 Small signal; $V_{DS} = 50\text{ V}$; $I_{Dq} = 20\text{ mA}$; $Z_S = Z_L = 50\ \Omega$

f (MHz)	S ₁₁		S ₂₁		S ₁₂		S ₂₂	
	Magnitude (ratio)	Angle (degree)	Magnitude (ratio)	Angle (degree)	Magnitude (ratio)	Angle (degree)	Magnitude (ratio)	Angle (degree)
3800	0.81362	135.09	2.337	-12.253	0.015073	36.394	0.75657	-152.33
3900	0.81344	132.46	2.2775	-15.177	0.016718	38.458	0.75891	-155.09
4000	0.81325	129.8	2.2215	-18.106	0.018506	39.738	0.76111	-157.86
4100	0.81305	127.11	2.1687	-21.043	0.020419	40.375	0.76318	-160.63
4200	0.81286	124.39	2.119	-23.991	0.022446	40.485	0.76513	-163.4
4300	0.81267	121.64	2.072	-26.952	0.024575	40.163	0.76694	-166.19
4400	0.8125	118.84	2.0276	-29.928	0.026802	39.483	0.76865	-168.99
4500	0.81236	116.01	1.9856	-32.922	0.029121	38.504	0.77023	-171.81
4600	0.81226	113.13	1.9457	-35.937	0.031528	37.269	0.77171	-174.65
4700	0.81221	110.22	1.9078	-38.976	0.034021	35.816	0.77309	-177.52
4800	0.81222	107.25	1.8718	-42.04	0.036598	34.172	0.77438	179.58
4900	0.81231	104.25	1.8374	-45.132	0.039257	32.359	0.77558	176.64
5000	0.81249	101.19	1.8045	-48.254	0.041996	30.394	0.77669	173.66
5100	0.81278	98.091	1.7729	-51.409	0.044813	28.293	0.77774	170.63
5200	0.81319	94.941	1.7426	-54.599	0.047706	26.065	0.77873	167.55
5300	0.81374	91.743	1.7133	-57.826	0.050674	23.72	0.77966	164.42
5400	0.81444	88.496	1.685	-61.092	0.053712	21.266	0.78055	161.22
5500	0.81531	85.202	1.6575	-64.4	0.056818	18.706	0.7814	157.96
5600	0.81637	81.859	1.6307	-67.75	0.059987	16.048	0.78224	154.63
5700	0.81764	78.47	1.6044	-71.146	0.063214	13.293	0.78307	151.22
5800	0.81912	75.035	1.5786	-74.588	0.066493	10.446	0.78391	147.73
5900	0.82083	71.556	1.5531	-78.079	0.069817	7.508	0.78477	144.15
6000	0.82279	68.034	1.5277	-81.619	0.073177	4.4824	0.78566	140.48

9. Package outline

Flanged ceramic package; 2 mounting holes; 2 leads

SOT1227A

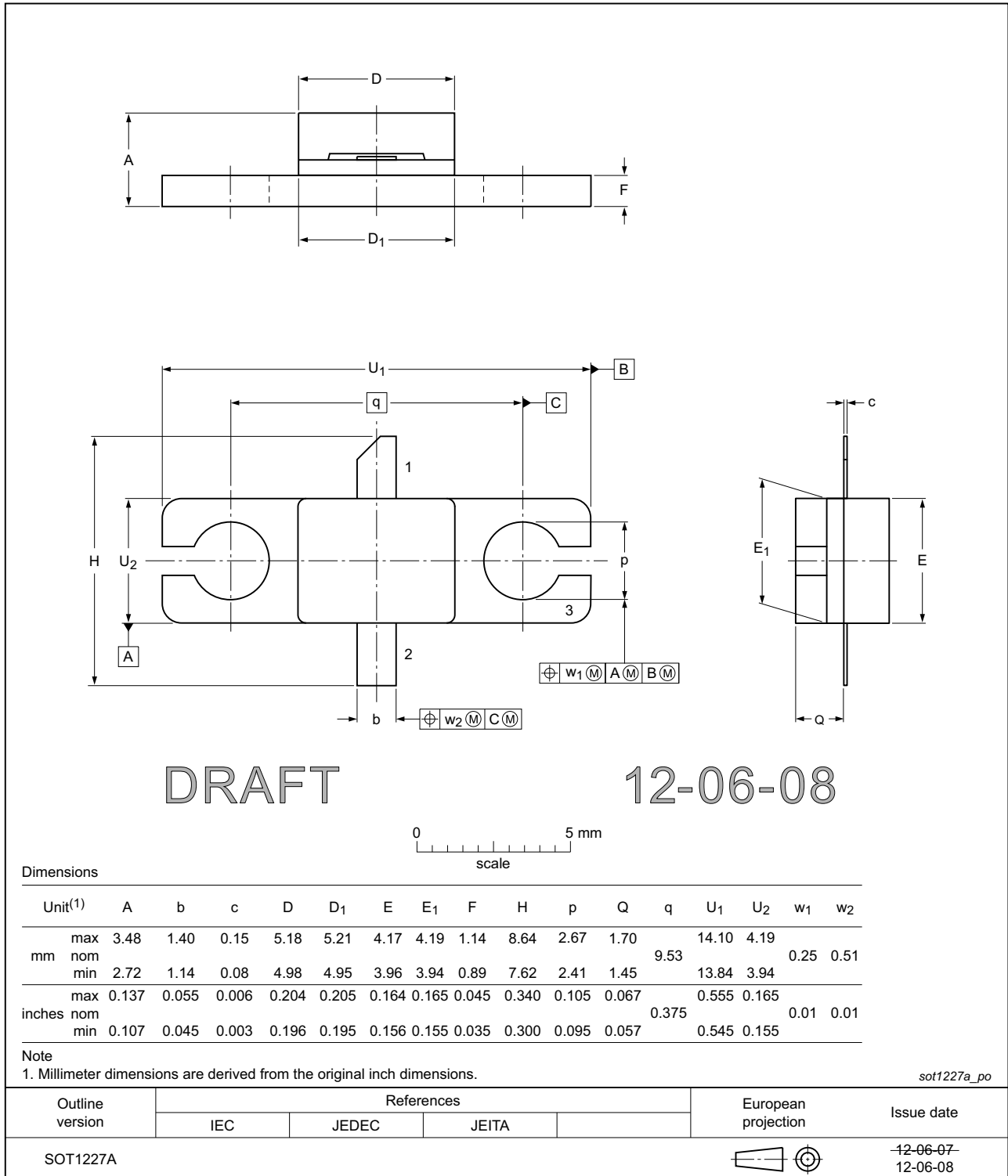

Fig 10. Package outline SOT1227A

Earless Flanged ceramic package; 2 leads

SOT1227B

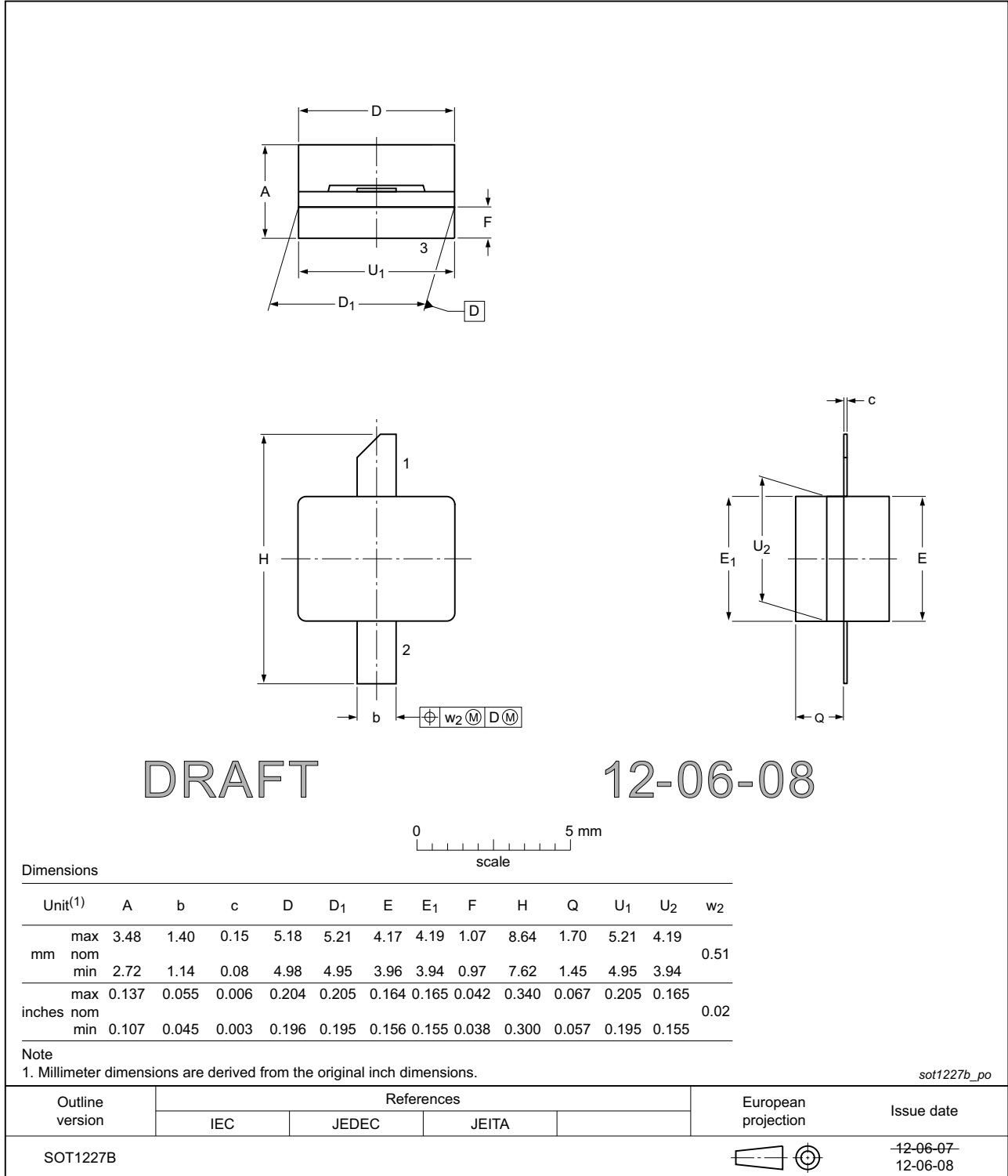

Fig 11. Package outline SOT1227B

10. Handling information

10.1 ESD Sensitivity

Table 14. ESD sensitivity

ESD model	Class
Human Body Model (HBM); According JEDEC standard JESD22-A114F	1B [1]

[1] Classification 1B is granted to any part that passes after exposure to an ESD pulse of 500 V, but fails after exposure to an ESD pulse of 1000 V.

11. Abbreviations

Table 15. Abbreviations

Acronym	Description
CW	Continuous Wave
EMC	ElectroMagnetic Compatibility
ESD	ElectroStatic Discharge
GaN	Gallium Nitride
HEMT	High Electron Mobility Transistor
SMD	Surface-Mounted Device
VSWR	Voltage Standing-Wave Ratio
WiMAX	Worldwide Interoperability for Microwave Access

12. Revision history

Table 16. Revision history

Document ID	Release date	Data sheet status	Change notice	Supersedes
CLF1G0060-10_1G0060S-10 v.2	20130129	Objective data sheet	-	CLF1G0060-10_1G0060S-10 v.1
Modifications:				
<ul style="list-style-type: none"> Table 7 on page 3: table has been updated. Table 8 on page 3: table has been updated. Section 7 on page 4: layout has been changed. Table 9 on page 4: row 1 has been changed. Section 8 on page 9: layout has been changed. 				
CLF1G0060-10_1G0060S-10 v.1	20121008	Objective data sheet	-	-

13. Legal information

13.1 Data sheet status

Document status ^{[1][2]}	Product status ^[3]	Definition
Objective [short] data sheet	Development	This document contains data from the objective specification for product development.
Preliminary [short] data sheet	Qualification	This document contains data from the preliminary specification.
Product [short] data sheet	Production	This document contains the product specification.

[1] Please consult the most recently issued document before initiating or completing a design.

[2] The term 'short data sheet' is explained in section "Definitions".

[3] The product status of device(s) described in this document may have changed since this document was published and may differ in case of multiple devices. The latest product status information is available on the Internet at URL <http://www.nxp.com>.

13.2 Definitions

Draft — The document is a draft version only. The content is still under internal review and subject to formal approval, which may result in modifications or additions. NXP Semiconductors does not give any representations or warranties as to the accuracy or completeness of information included herein and shall have no liability for the consequences of use of such information.

Short data sheet — A short data sheet is an extract from a full data sheet with the same product type number(s) and title. A short data sheet is intended for quick reference only and should not be relied upon to contain detailed and full information. For detailed and full information see the relevant full data sheet, which is available on request via the local NXP Semiconductors sales office. In case of any inconsistency or conflict with the short data sheet, the full data sheet shall prevail.

Product specification — The information and data provided in a Product data sheet shall define the specification of the product as agreed between NXP Semiconductors and its customer, unless NXP Semiconductors and customer have explicitly agreed otherwise in writing. In no event however, shall an agreement be valid in which the NXP Semiconductors product is deemed to offer functions and qualities beyond those described in the Product data sheet.

13.3 Disclaimers

Limited warranty and liability — Information in this document is believed to be accurate and reliable. However, NXP Semiconductors does not give any representations or warranties, expressed or implied, as to the accuracy or completeness of such information and shall have no liability for the consequences of use of such information. NXP Semiconductors takes no responsibility for the content in this document if provided by an information source outside of NXP Semiconductors.

In no event shall NXP Semiconductors be liable for any indirect, incidental, punitive, special or consequential damages (including - without limitation - lost profits, lost savings, business interruption, costs related to the removal or replacement of any products or rework charges) whether or not such damages are based on tort (including negligence), warranty, breach of contract or any other legal theory.

Notwithstanding any damages that customer might incur for any reason whatsoever, NXP Semiconductors' aggregate and cumulative liability towards customer for the products described herein shall be limited in accordance with the *Terms and conditions of commercial sale* of NXP Semiconductors.

Right to make changes — NXP Semiconductors reserves the right to make changes to information published in this document, including without limitation specifications and product descriptions, at any time and without notice. This document supersedes and replaces all information supplied prior to the publication hereof.

Suitability for use — NXP Semiconductors products are not designed, authorized or warranted to be suitable for use in life support, life-critical or safety-critical systems or equipment, nor in applications where failure or malfunction of an NXP Semiconductors product can reasonably be expected to result in personal injury, death or severe property or environmental damage. NXP Semiconductors and its suppliers accept no liability for inclusion and/or use of NXP Semiconductors products in such equipment or applications and therefore such inclusion and/or use is at the customer's own risk.

Applications — Applications that are described herein for any of these products are for illustrative purposes only. NXP Semiconductors makes no representation or warranty that such applications will be suitable for the specified use without further testing or modification.

Customers are responsible for the design and operation of their applications and products using NXP Semiconductors products, and NXP Semiconductors accepts no liability for any assistance with applications or customer product design. It is customer's sole responsibility to determine whether the NXP Semiconductors product is suitable and fit for the customer's applications and products planned, as well as for the planned application and use of customer's third party customer(s). Customers should provide appropriate design and operating safeguards to minimize the risks associated with their applications and products.

NXP Semiconductors does not accept any liability related to any default, damage, costs or problem which is based on any weakness or default in the customer's applications or products, or the application or use by customer's third party customer(s). Customer is responsible for doing all necessary testing for the customer's applications and products using NXP Semiconductors products in order to avoid a default of the applications and the products or of the application or use by customer's third party customer(s). NXP does not accept any liability in this respect.

Limiting values — Stress above one or more limiting values (as defined in the Absolute Maximum Ratings System of IEC 60134) will cause permanent damage to the device. Limiting values are stress ratings only and (proper) operation of the device at these or any other conditions above those given in the Recommended operating conditions section (if present) or the Characteristics sections of this document is not warranted. Constant or repeated exposure to limiting values will permanently and irreversibly affect the quality and reliability of the device.

Terms and conditions of commercial sale — NXP Semiconductors products are sold subject to the general terms and conditions of commercial sale, as published at <http://www.nxp.com/profile/terms>, unless otherwise agreed in a valid written individual agreement. In case an individual agreement is concluded only the terms and conditions of the respective agreement shall apply. NXP Semiconductors hereby expressly objects to applying the customer's general terms and conditions with regard to the purchase of NXP Semiconductors products by customer.

No offer to sell or license — Nothing in this document may be interpreted or construed as an offer to sell products that is open for acceptance or the grant, conveyance or implication of any license under any copyrights, patents or other industrial or intellectual property rights.

Export control — This document as well as the item(s) described herein may be subject to export control regulations. Export might require a prior authorization from competent authorities.

Non-automotive qualified products — Unless this data sheet expressly states that this specific NXP Semiconductors product is automotive qualified, the product is not suitable for automotive use. It is neither qualified nor tested in accordance with automotive testing or application requirements. NXP Semiconductors accepts no liability for inclusion and/or use of non-automotive qualified products in automotive equipment or applications.

In the event that customer uses the product for design-in and use in automotive applications to automotive specifications and standards, customer (a) shall use the product without NXP Semiconductors' warranty of the product for such automotive applications, use and specifications, and (b) whenever customer uses the product for automotive applications beyond

NXP Semiconductors' specifications such use shall be solely at customer's own risk, and (c) customer fully indemnifies NXP Semiconductors for any liability, damages or failed product claims resulting from customer design and use of the product for automotive applications beyond NXP Semiconductors' standard warranty and NXP Semiconductors' product specifications.

Translations — A non-English (translated) version of a document is for reference only. The English version shall prevail in case of any discrepancy between the translated and English versions.

13.4 Trademarks

Notice: All referenced brands, product names, service names and trademarks are the property of their respective owners.

14. Contact information

For more information, please visit: <http://www.nxp.com>

For sales office addresses, please send an email to: salesaddresses@nxp.com

15. Contents

1	Product profile	1
1.1	General description	1
1.2	Features and benefits	2
1.3	Applications	2
2	Pinning information	2
3	Ordering information	2
4	Limiting values	3
5	Thermal characteristics	3
6	Characteristics	3
7	Application information	4
7.1	Demo circuit	4
7.2	Application test results	6
7.3	Graphical data	7
7.3.1	1-Tone CW RF performance	7
7.3.2	1-Tone pulsed RF performance	8
7.3.3	2-Tone CW performance	9
7.3.4	Bias module	9
8	Test information	9
8.1	Ruggedness in class-AB operation	9
8.2	Load pull impedance information	9
8.3	Packaged S-parameter data	11
9	Package outline	13
10	Handling information	15
10.1	ESD Sensitivity	15
11	Abbreviations	15
12	Revision history	15
13	Legal information	16
13.1	Data sheet status	16
13.2	Definitions	16
13.3	Disclaimers	16
13.4	Trademarks	17
14	Contact information	17
15	Contents	18

Please be aware that important notices concerning this document and the product(s) described herein, have been included in section 'Legal information'.

© NXP B.V. 2013.

All rights reserved.

For more information, please visit: <http://www.nxp.com>

For sales office addresses, please send an email to: salesaddresses@nxp.com

Date of release: 29 January 2013

Document identifier: CLF1G0060-10_1G0060S-10