

REVISIONS

| LTR | DESCRIPTION   | DATE          | APPROVED       |
|-----|---|---------------|----------------|
| A   | Page 4: Correct table I to correspond with military specification requirements.   | 05 Aug. 1979  | N. A. Hauck    |
| B   | Change from suggested source drawing to approved source drawing. Editorial changes throughout.  | 4 May 86      | N. A. Hauck    |
| C   | Change to military drawing format. Add alternate group A programmability sample test. Update vendors part number. Make changes to screening and group A inspection. | 2 June 1987   | N. A. Hauck    |
| D   | Add device 02. Editorial changes throughout.  | 22 Jan. 1988  | M. A. Frye     |
| E   | Changes in accordance with NOR 5962-R080-96.  | 22 March 1996 | M. A. Frye     |
| F   | Updated boilerplate. Removed programming specifics from drawing, including table III and table IV. Separated source bulletin from body of drawing. - glg            | 07-08-00      | Raymond Monnin |

THE ORIGINAL FIRST PAGE OF THIS DRAWING HAS BEEN REPLACED.

**CURRENT CAGE CODE 67268**

|  |   |  |                    |              |   |   |   |   |   |   |   |  |  |  |  |  |  |  |  |  |  |
|--|---|--|--------------------|--------------|---|---|---|---|---|---|---|--|--|--|--|--|--|--|--|--|--|
| REV  |   |  |                    |              |   |   |   |   |   |   |   |  |  |  |  |  |  |  |  |  |  |
| SHEET  |   |  |                    |              |   |   |   |   |   |   |   |  |  |  |  |  |  |  |  |  |  |
| REV  |   |  |                    |              |   |   |   |   |   |   |   |  |  |  |  |  |  |  |  |  |  |
| SHEET  |   |  |                    |              |   |   |   |   |   |   |   |  |  |  |  |  |  |  |  |  |  |
| REV STATUS OF SHEETS   | REV                                       | F  | F                  | F            | F | F | F | F | F | F | F |  |  |  |  |  |  |  |  |  |  |
|  | SHEET                                     | 1  | 2                  | 3            | 4 | 5 | 6 | 7 | 8 | 9 |   |  |  |  |  |  |  |  |  |  |  |
| PMIC N/A   | PREPARED BY<br>Rick C. Officer            | <b>DEFENSE SUPPLY CENTER COLUMBUS<br/>COLUMBUS, OHIO 43216</b>                                   |                    |              |   |   |   |   |   |   |   |  |  |  |  |  |  |  |  |  |  |
| <b>STANDARD<br/>MICROCIRCUIT<br/>DRAWING</b>   | CHECKED BY<br>D. A. DiCenzo               |  |                    |              |   |   |   |   |   |   |   |  |  |  |  |  |  |  |  |  |  |
| THIS DRAWING IS AVAILABLE FOR USE BY ALL DEPARTMENTS AND AGENCIES OF THE DEPARTMENT OF DEFENSE<br><br>AMSC N/A | APPROVED BY<br>N. A. Hauck                | <b>MICROCIRCUITS, MEMORY, DIGITAL,<br/>CMOS, 8K x 8 UV ERASABLE PROM,<br/>MONOLITHIC SILICON</b> |                    |              |   |   |   |   |   |   |   |  |  |  |  |  |  |  |  |  |  |
|  | DRAWING APPROVAL DATE<br>20 February 1979 |  |                    |              |   |   |   |   |   |   |   |  |  |  |  |  |  |  |  |  |  |
|  | REVISION LEVEL<br>F                       | SIZE<br>A  | CAGE CODE<br>14933 | <b>78016</b> |   |   |   |   |   |   |   |  |  |  |  |  |  |  |  |  |  |
|  |   | SHEET  |                    | 1 OF 9       |   |   |   |   |   |   |   |  |  |  |  |  |  |  |  |  |  |

1. SCOPE

1.1 Scope. This drawing describes device requirements for MIL-STD-883 compliant, non-JAN class level B microcircuits in accordance with MIL-PRF-38535, appendix A.

1.2 Part or Identifying Number (PIN). The complete PIN shall be as shown in the following example:

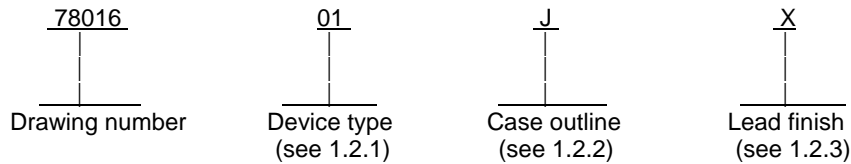

1.2.1 Device type(s). The device type(s) shall identify the circuit function as follows:

| <u>Device type</u> | <u>Generic number</u> | <u>Circuit</u>            | <u>Access time</u> |
|--------------------|-----------------------|---------------------------|--------------------|
| 01                 | 1/                    | 512 x 8-bit Schottky PROM | 90 ns              |
| 02                 | 1/                    | 512 x 8-bit Schottky PROM | 45 ns              |

1.2.2 Case outline(s). The case outline(s) shall be as designated in MIL-STD-1835, and as follows:

| <u>Outline letter</u> | <u>Descriptive designator</u> | <u>Terminals</u> | <u>Package style</u>                 |
|-----------------------|-------------------------------|------------------|--------------------------------------|
| J                     | GDIP1-T24 or CDIP2-T24        | 24               | dual-in-line package                 |
| K                     | GDFP2-F24 or CDFP3-F24        | 24               | flat package                         |
| U                     | CQCC1-N32                     | 32               | rectangular chip carrier package     |
| 3                     | CQCC1-N28                     | 28               | square leadless chip carrier package |

1.2.3 Lead finish. The lead finish is as specified in MIL-PRF-38535, appendix A.

1.3 Absolute maximum ratings.

|   |                        |
|---|------------------------|
| Supply voltage range.....                                       | -0.5 V dc to +7.0 V dc |
| Input voltage range .....                                       | -1.5 V dc to +5.5 V dc |
| Storage temperature range .....                                 | -65°C to +150°C        |
| Maximum power dissipation (P <sub>D</sub> ): 2/.....            | 1.02 W                 |
| Lead temperature (soldering, 10 seconds) .....                  | +300°C                 |
| Thermal resistance, junction-to-case (θ <sub>JC</sub> ) 3/..... | See MIL-STD-1835       |
| Maximum junction temperature (T <sub>J</sub> ) .....            | +175°C                 |
| Output sink current.....  | 100 mA                 |

1.4 Recommended operating conditions.

|   |                      |
|---|----------------------|
| Case operating temperature range (T <sub>C</sub> )..... | -55°C to +125°C      |
| Input low voltage ±10% supply (V <sub>IL</sub> ) .....  | 0.8 V dc             |
| Input high voltage ±10% supply (V <sub>IH</sub> ).....  | 2.0 V dc             |
| Supply voltage range (V <sub>CC</sub> ) .....           | 4.5 V dc to 5.5 V dc |

1/ Generic numbers are listed on the Standard Microcircuit Drawing Source Approval Bulletin at the end of this document and will also be listed in MIL-HDBK-103.

2/ Must withstand the added P<sub>D</sub> due to short-circuit test; e.g., I<sub>OS</sub>.

3/ Heat sinking is recommended to reduce the junction temperature.

|   |                   |                     |              |
|---|-------------------|---------------------|--------------|
| <b>STANDARD<br/>MICROCIRCUIT DRAWING</b>                            | <b>SIZE<br/>A</b> |                     | <b>78016</b> |
| <b>DEFENSE SUPPLY CENTER COLUMBUS<br/>COLUMBUS, OHIO 43216-5000</b> |                   | REVISION LEVEL<br>F | SHEET<br>2   |

2. APPLICABLE DOCUMENTS

2.1 Government specification, standards, and handbooks. The following specification, standards and handbooks form a part of this drawing to the extent specified herein. Unless otherwise specified, the issues of these documents are those listed in the issue listed in the issue of the Department of Defense Index of Specifications and Standards (DoDISS) and supplement thereto, cited in the solicitation.

SPECIFICATION

DEPARTMENT OF DEFENSE

MIL-PRF-38535 - Integrated Circuits, Manufacturing, General Specification for.

STANDARDS

DEPARTMENT OF DEFENSE

MIL-STD-883 - Test Method Standard Microcircuits.  
 MIL-STD-973 - Configuration Management.  
 MIL-STD-1835 - Interface Standard For Microcircuit Case Outlines.

HANDBOOKS

DEPARTMENT OF DEFENSE

MIL-HDBK-103 - List of Standard Microcircuit Drawings (SMD's).  
 MIL-HDBK-780 - Standard Microcircuit Drawings.

(Unless otherwise indicated, copies of the specification, standards, and handbooks are available from the Standardization Document Order Desk, 700 Robbins Avenue, Building 4D, Philadelphia, PA 19111-5094.)

2.2 Order of precedence. In the event of a conflict between the text of this drawing and the references cited herein, the text of this drawing shall take precedence. Nothing in this document, however, supersedes applicable laws and regulations unless a specific exemption has been obtained.

3. REQUIREMENTS

3.1 Item requirements The individual item requirements shall be in accordance with MIL-PRF-38535, appendix A for non-JAN class level B devices and as specified herein. Product built to this drawing that is produced by a Qualified Manufacturer Listing (QML) certified and qualified manufacturer or a manufacturer who has been granted transitional certification to MIL-PRF-38535 may be processed as QML product in accordance with the manufacturer's approved program plan and qualifying activity approval in accordance with MIL-PRF-38535. This QML flow as documented in the Quality Management (QM) plan may make modifications to the requirements herein. These modifications shall not affect the PIN as described herein. A "Q" or "QML" certification mark in accordance with MIL-PRF-38535 is required to identify when the QML flow option is used.

3.2 Design, construction, and physical dimensions. The design, construction, and physical dimensions shall be as specified in MIL-PRF-38535, appendix A and herein.

3.2.1 Terminal connections. The terminal connections shall be as specified on figure 1.

3.2.2 Case outlines. The case outlines shall be in accordance with 1.2.2 herein.

3.3 Electrical performance characteristics. Unless otherwise specified herein, the electrical performance characteristics are as specified in table I and shall apply over the full case operating temperature range.

3.4 Electrical test requirements. The electrical test requirements shall be the subgroups specified in table II. The electrical tests for each subgroup are described in table I.

3.5 Marking. Marking shall be in accordance with MIL-PRF-38535, appendix A. The part shall be marked with the PIN listed in 1.2 herein. In addition, the manufacturer's PIN may also be marked as listed in MIL-HDBK-103 (see 6.6 herein). For packages where the entire SMD PIN number is not feasible due to space limitations, the manufacturer has the option of not marking the "5962-" on the device.

|   |                  |                     |              |
|---|------------------|---------------------|--------------|
| <b>STANDARD<br/>MICROCIRCUIT DRAWING</b><br><br><b>DEFENSE SUPPLY CENTER COLUMBUS<br/>COLUMBUS, OHIO 43216-5000</b> | SIZE<br><b>A</b> |                     | <b>78016</b> |
|   |                  | REVISION LEVEL<br>F | SHEET<br>3   |

TABLE I. Electrical performance characteristics.

| Test   | Symbol            | Conditions<br>-55°C ≤ T <sub>C</sub> ≤ +125°C<br>4.5 V ≤ V <sub>CC</sub> ≤ 5.5 V<br>unless otherwise specified | Group A<br>subgroups | Device<br>type  | Limits |                 | Unit |
|--|-------------------|--|----------------------|-----------------|--------|-----------------|------|
|  |                   |  |                      |                 | Min    | Max             |      |
| High level output voltage                      | V <sub>OH</sub>   | V <sub>IL</sub> = 0.8 V, V <sub>IH</sub> = 2.0 V<br>I <sub>OH</sub> = -2.0 mA, V <sub>CC</sub> = 4.5 V         | 1, 2, 3              | All             | 2.4    |                 | V    |
| Low level output voltage                       | V <sub>OL</sub>   | V <sub>IL</sub> = 0.8 V, V <sub>IH</sub> = 2.0 V<br>I <sub>OL</sub> = 8 mA, V <sub>CC</sub> = 4.5 V            | 1, 2, 3              | All             |        | 0.5             | V    |
| Input clamp voltage                            | V <sub>IC</sub>   | V <sub>CC</sub> = 4.5 V, I <sub>IN</sub> = -18 mA  | 1, 2, 3              | All             |        | -1.2            | V    |
| High impedance (off-state) output high current | I <sub>OHZ</sub>  | V <sub>CC</sub> = 5.5 V, V <sub>O</sub> = 5.2 V  | 1, 2, 3              | All             |        | 100             | μA   |
| High impedance (off-state) output low current  | I <sub>OLZ</sub>  | V <sub>CC</sub> = 5.5 V, V <sub>O</sub> = 0.5 V  | 1, 2, 3              | All             |        | -100            | μA   |
| High level input current                       | I <sub>IH</sub>   | V <sub>CC</sub> = 5.5 V, V <sub>IN</sub> = 5.5 V   | 1, 2, 3              | All             |        | 50              | μA   |
| Low level input current                        | I <sub>IL</sub>   | V <sub>CC</sub> = 5.5 V, V <sub>IN</sub> = 0.5 V   | 1, 2, 3              | All             | -1.0   | -250            | μA   |
| Output short-circuit current                   | I <sub>OS</sub>   | V <sub>CC</sub> = 5.5 V, V <sub>O</sub> = 0 V <sup>1/</sup>  | 1, 2, 3              | All             | -10    | -100            | mA   |
| Supply current                                 | I <sub>CC</sub>   | V <sub>CC</sub> = 5.5 V, V <sub>IN</sub> = 0 V<br>Outputs open   | 1, 2, 3              | All             |        | 185             | mA   |
| Propagation delay time, address to output      | t <sub>AVQV</sub> | V <sub>CC</sub> = 4.5 V and 5.5 V<br>C <sub>L</sub> = 30 pF  | 9, 10, 11            | <u>01</u><br>02 |        | <u>90</u><br>45 | ns   |
| Propagation delay time, enable to output       | t <sub>EVQV</sub> | V <sub>CC</sub> = 4.5 V and 5.5 V<br>C <sub>L</sub> = 30 pF  | 9, 10, 11            | <u>01</u><br>02 |        | <u>50</u><br>25 | ns   |

<sup>1/</sup> Not more than one output shall be grounded at one time. Output shall be at high logic level prior to test.

|   |                   |                     |              |
|---|-------------------|---------------------|--------------|
| <b>STANDARD<br/>MICROCIRCUIT DRAWING</b><br><br><b>DEFENSE SUPPLY CENTER COLUMBUS<br/>COLUMBUS, OHIO 43216-5000</b> | <b>SIZE<br/>A</b> |                     | <b>78016</b> |
|   |                   | REVISION LEVEL<br>F | SHEET<br>4   |

3.5.1 Certification/compliance mark. The compliance mark for device class M shall be a "C" as required in MIL-PRF-38535, Appendix A.

3.6 Certificate of compliance. A certificate of compliance shall be required from a manufacturer in order to be listed as an approved source of supply in MIL-HDBK-103 (see 6.6 herein). The certificate of compliance submitted to DSCC-VA prior to listing as an approved source of supply shall affirm that the manufacturer's product meets the requirements of MIL-PRF-38535, appendix A and the requirements herein.

3.7 Certificate of conformance. A certificate of conformance as required in MIL-PRF-38535, appendix A shall be provided with each lot of microcircuits delivered to this drawing.

3.8 Notification of change. Notification of change to DSCC-VA shall be required in accordance with MIL-PRF-38535, appendix A.

3.9 Verification and review. DSCC, DSCC's agent and the acquiring activity retain the option to review the manufacturer's facility and applicable required documentation. Offshore documentation shall be made available onshore at the option of the reviewer.

3.10 Processing options. Since the PROM is an unprogrammed memory capable of being programmed by either the manufacturer or the user to result in a wide variety of PROM configurations, two processing options are provided for the selection in the contract, using an altered item drawing.

3.10.1 Unprogrammed PROM delivered to the user. All testing shall be verified through group A testing as defined in table II. It is recommended that users perform subgroups 7 and 9 after programming to verify the specific program configuration.

3.10.2 Manufacturer-programmed PROM delivered to the user. All testing requirements and quality assurance provisions herein, including the requirements of the altered item drawing shall be satisfied by the manufacturer prior to delivery.

#### 4. QUALITY ASSURANCE PROVISIONS

4.1 Sampling and inspection. Sampling and inspection procedures shall be in accordance with MIL-PRF-38535, appendix A.

4.2 Screening. Screening shall be in accordance with method 5004 of MIL-STD-883, and shall be conducted on all devices prior to quality conformance inspection. The following additional criteria shall apply:

a. Burn-in test (method 1015 of MIL-STD-883).

(1) Test condition A, B, C or D. The test circuit shall be maintained by the manufacturer under document revision level control and shall be made available to the preparing or procuring activity upon request. The test circuit shall specify the inputs, outputs, biases, and power dissipation, as applicable, in accordance with the intent specified in test method 1015 of MIL-STD-883.

(2)  $T_A = +125^{\circ}\text{C}$ , minimum.

b. Interim and final electrical test parameters shall be as specified in table II herein, except interim electrical parameter tests prior to burn-in are optional at the discretion of the manufacturer.

c. All devices processed to an altered item drawing may be programmed either before or after burn-in at the discretion of the manufacturer. The required electrical testing shall include, as a minimum, the final electrical tests for programmed devices as specified in table II.

|  |   |                     |              |
|--|---|---------------------|--------------|
| <b>STANDARD<br/>MICROCIRCUIT DRAWING</b> | <b>SIZE<br/>A</b>   |                     | <b>78016</b> |
|  | <b>DEFENSE SUPPLY CENTER COLUMBUS<br/>COLUMBUS, OHIO 43216-5000</b> | REVISION LEVEL<br>F | SHEET<br>5   |

| Device Types    | All             |                 |                 |                 |
|-----------------|-----------------|-----------------|-----------------|-----------------|
| Case Outlines   | J, K            |                 | U               | 3               |
| Terminal Number | Terminal Symbol | Terminal Number | Terminal Symbol | Terminal Symbol |
| 1               | A7              | 1               | NC              | NC              |
| 2               | A6              | 2               | NC              | A7              |
| 3               | A5              | 3               | A7              | A6              |
| 4               | A4              | 4               | A6              | A5              |
| 5               | A3              | 5               | A5              | A4              |
| 6               | A2              | 6               | A4              | A3              |
| 7               | A1              | 7               | A3              | A2              |
| 8               | A0              | 8               | A2              | A1              |
| 9               | Q1              | 9               | A1              | A0              |
| 10              | Q2              | 10              | A0              | NC              |
| 11              | Q3              | 11              | NC              | Q1              |
| 12              | VSS             | 12              | Q1              | Q2              |
| 13              | Q4              | 13              | Q2              | Q3              |
| 14              | Q5              | 14              | Q3              | VSS             |
| 15              | Q6              | 15              | NC              | NC              |
| 16              | Q7              | 16              | VSS             | Q4              |
| 17              | Q8              | 17              | Q4              | Q5              |
| 18              | CE4             | 18              | NC              | Q6              |
| 19              | CE3             | 19              | Q5              | Q7              |
| 20              | CE 2            | 20              | Q6              | Q8              |
| 21              | CE 1            | 21              | Q7              | NC              |
| 22              | NC              | 22              | Q8              | CE4             |
| 23              | A8              | 23              | NC              | CE3             |
| 24              | VCC             | 24              | CE4             | CE 2            |
| 25              | ---             | 25              | CE3             | CE 1            |
| 26              | ---             | 26              | CE 2            | NC              |
| 27              | ---             | 27              | NC              | A8              |
| 28              | ---             | 28              | CE 1            | VCC             |
| 29              | ---             | 29              | NC              | ---             |
| 30              | ---             | 30              | A8              | ---             |
| 31              | ---             | 31              | NC              | ---             |
| 32              | ---             | 32              | VCC             | ---             |

FIGURE 1. Terminal connections.

|   |                  |                     |              |
|---|------------------|---------------------|--------------|
| <b>STANDARD<br/>MICROCIRCUIT DRAWING</b><br><br><b>DEFENSE SUPPLY CENTER COLUMBUS<br/>COLUMBUS, OHIO 43216-5000</b> | SIZE<br><b>A</b> |                     | <b>78016</b> |
|   |                  | REVISION LEVEL<br>F | SHEET<br>6   |

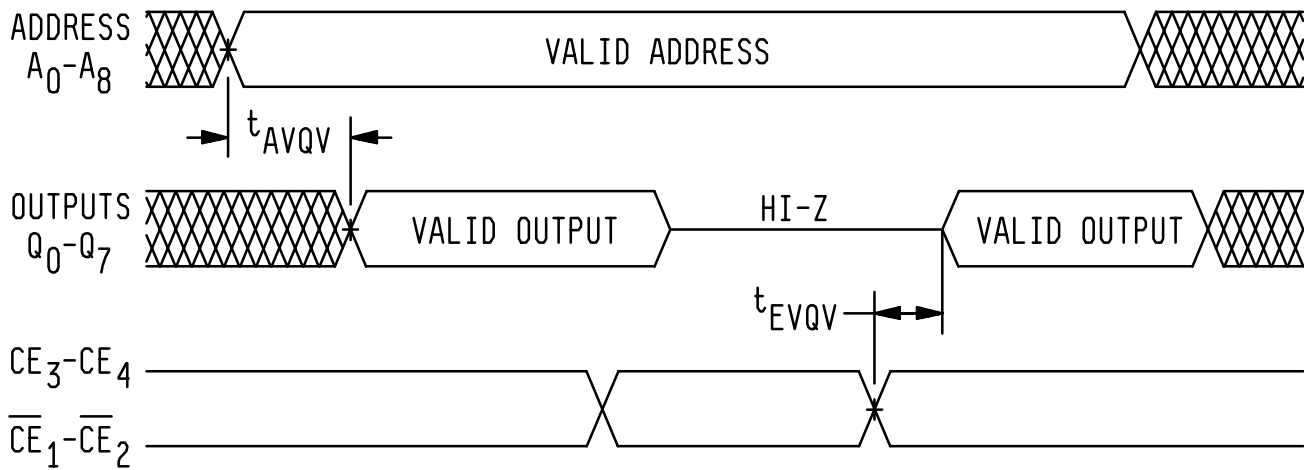

NOTE:

1. AC characteristics tested with input transition time of 5 ns or less, timing reference levels of 1.5 V, and input pulse levels of 0 to 3.0 V using test load circuit provided by the manufacturer.

FIGURE 2. Timing waveform.

|   |                  |                     |              |
|---|------------------|---------------------|--------------|
| <b>STANDARD<br/>MICROCIRCUIT DRAWING</b><br><br><b>DEFENSE SUPPLY CENTER COLUMBUS<br/>COLUMBUS, OHIO 43216-5000</b> | SIZE<br><b>A</b> |                     | <b>78016</b> |
|   |                  | REVISION LEVEL<br>F | SHEET<br>7   |

TABLE II. Electrical test requirements. 1/ 2/

|   |                                      |
|---|--------------------------------------|
| MIL-STD-883 test requirements   | Subgroups (per method 5005, table I) |
| Interim electrical parameters (method 5004)                             | ---                                  |
| Final electrical test parameters (method 5004) for unprogrammed devices | 1*, 2, 3, 7*, 8                      |
| Final electrical test parameters (method 5004) for programmed devices   | 1*, 2, 3, 7*, 8, 9                   |
| Group A test requirements (method 5005)                                 | 1, 2, 3, 7, 8, 9, 10, 11             |
| Groups C and D end-point electrical parameters (method 5005)            | 1, 2, 3                              |

\* PDA applies to subgroups 1 and 7.

4.3 Quality conformance inspection. Quality conformance inspection shall be in accordance with method 5005 of MIL-STD-883 including groups A, C, and D inspections. The following additional criteria shall apply.

4.3.1 Group A inspection.

- a. Tests shall be as specified in table II herein.
- b. Subgroups 4, 5 and 6 in table I, method 5005 of MIL-STD-883 shall be omitted.
- c. Unprogrammed devices shall be tested for programmability and ac performance compliance to the requirements of group A, subgroups 9, 10, and 11. Either of two techniques is acceptable.
  - (1) Testing the entire lot using additional built-in test circuitry which allows the manufacturer to verify programmability and ac performance without programming the user array. If this is done, the resulting test patterns shall be verified on all devices during subgroups 9, 10, and 11, group A testing per the sampling plan specified in MIL-STD-883, method 5005.
  - (2) If such compliance cannot be tested on an unprogrammed device, a sample shall be selected to satisfy programmability requirements prior to performing subgroups 9, 10, and 11. Twelve devices shall be submitted to programming. If more than 2 devices fail to program, the lot shall be rejected. At the manufacturer's option, the sample may be increased to 24 total devices with no more than 4 total device failures allowable. Ten devices from the programmability sample shall be submitted to the requirements of group A, subgroups 9, 10, and 11. If more than 2 total devices fail, the lot shall be rejected. At the manufacturer's option, the sample may be increased to 20 total devices with no more than 4 total device failures allowable.
- d. Subgroup 7 and 8 must verify input to output logic combinations.

|   |                  |                     |              |
|---|------------------|---------------------|--------------|
| <b>STANDARD<br/>MICROCIRCUIT DRAWING</b><br><br><b>DEFENSE SUPPLY CENTER COLUMBUS<br/>COLUMBUS, OHIO 43216-5000</b> | SIZE<br><b>A</b> |                     | <b>78016</b> |
|   |                  | REVISION LEVEL<br>F | SHEET<br>8   |



4.3.2 Groups C and D inspections.

- a. End-point electrical parameters shall be as specified in table II herein.
- b. Steady-state life test conditions, method 1005 of MIL-STD-883.
  - (1) Test condition A, B, C or D. The test circuit shall be maintained by the manufacturer under document revision level control and shall be made available to the preparing or procuring activity upon request. The test circuit shall specify the inputs, outputs, biases, and power dissipation, as applicable, in accordance with the intent specified in test method 1005 of MIL-STD-883.
  - (2)  $T_A = +125^{\circ}\text{C}$ , minimum.
  - (3) Test duration: 1,000 hours, except as permitted by method 1005 of MIL-STD-883
- c. The programmability sample (see 4.3.1c) shall be included in subgroup 1 tests.

5. PACKAGING

5.1 Packaging requirements. The requirements for packaging shall be in accordance with MIL-PRF-38535, appendix A.

6. NOTES

6.1 Intended use. Microcircuits conforming to this drawing are intended for use for government microcircuit applications (original equipment), design applications, and logistics purposes.

6.2 Replaceability. Microcircuits covered by this drawing will replace the same generic device covered by a contractor-prepared specification or drawing.

6.3 Configuration control of SMD's. All proposed changes to existing SMD's will be coordinated with the users of record for the individual documents. This coordination will be accomplished in accordance with MIL-STD-973 using DD Form 1692, Engineering Change Proposal.

6.4 Record of users. Military and industrial users should inform Defense Supply Center Columbus when a system application requires configuration control and which SMD's are applicable to that system. DSCC will maintain a record of users and this list will be used for coordination and distribution of changes to the drawings. Users of drawings covering microelectronic devices (FSC 5962) should contact DSCC-VA, telephone (614) 692-0525.

6.5 Comments. Comments on this drawing should be directed to DSCC-VA, Columbus, Ohio 43216-5000, or telephone 614-692-0674.

6.6 Approved source of supply. An approved source of supply is listed herein. Additional sources will be added as they become available. The vendor listed herein has agreed to this drawing and a certificate of compliance (see 3.6 herein ) has been submitted to DSCC-VA.

|  |                  |                     |              |
|--|------------------|---------------------|--------------|
| <b>STANDARD<br/>MICROCIRCUIT DRAWING</b> | SIZE<br><b>A</b> |                     | <b>78016</b> |
|  |                  | REVISION LEVEL<br>F | SHEET<br>9   |

STANDARD MICROCIRCUIT DRAWING BULLETIN

DATE: 07-08-00

Approved sources of supply for SMD 78016 are listed below for immediate acquisition information only and shall be added to MIL-HDBK-103 and QML-38535 during the next revision. MIL-HDBK-103 and QML-38535 will be revised to include the addition or deletion of sources. The vendors listed below have agreed to this drawing and a certificate of compliance has been submitted to and accepted by DSCC-VA. This bulletin is superseded by the next dated revisions of MIL-HDBK-103 and QML-38535.

| Standard microcircuit drawing PIN <u>1/</u> | Vendor CAGE number | Vendor similar PIN <u>2/</u> |
|---|--------------------|------------------------------|
| 7801601JA                                   | 0C7V7              | 82S141/BJA                   |
|   | 58625              | SL82S141/BJA                 |
| 7801601KA                                   | 3/                 | AM27S31/BJA                  |
|   | 0C7V7              | 82S141/BKA                   |
| 78016013A                                   | 58625              | SL82S141/BKA                 |
|   | 3/                 | AM27S31/BKA                  |
| 7801601UA                                   | 0C7V7              | 82S141/B3A                   |
|   | 58625              | SL82S141/B3A                 |
| 7801602JA                                   | 3/                 | AM27S31/B3A                  |
|   | 3/                 | AM27S31/BUA                  |
| 7801602KA                                   | 3/                 | AM27S31A/BJA                 |
| 78016023A                                   | 3/                 | AM27S31A/BKA                 |
| 7801602UA                                   | 3/                 | AM27S31A/B3A                 |
| 7801602UA                                   | 3/                 | AM27S31A/BUA                 |

- 1/ The lead finish shown for each PIN representing a hermetic package is the most readily available from the manufacturer listed for that part. If the desired lead finish is not listed contact the Vendor to determine its availability.
- 2/ **Caution.** Do not use this number for item acquisition. Items acquired to this number may not satisfy the performance requirements of this drawing.
- 3/ No longer available from an approved source.

Vendor CAGE number

Vendor name and address

0C7V7

QP LABS  
3605 Kifer Road  
Santa Clara, CA 95051

58625

Lansdale Semiconductor Inc.  
2412 W. Huntington Drive  
Tempe, AZ 85282-3134

The information contained herein is disseminated for convenience only and the Government assumes no liability whatsoever for any inaccuracies in the information bulletin.