

REVISIONS

P	LTR	DESCRIPTION	DATE	DWN	APVD
	E	REV/ 0720-0612-95	31MAY95	-	ME
	E1	REVISED PER ECO-17-014338	29MAR2018	RS	DR

 <b>E13288</b> Listed
22-16 AWG SOLID OR STRANDED

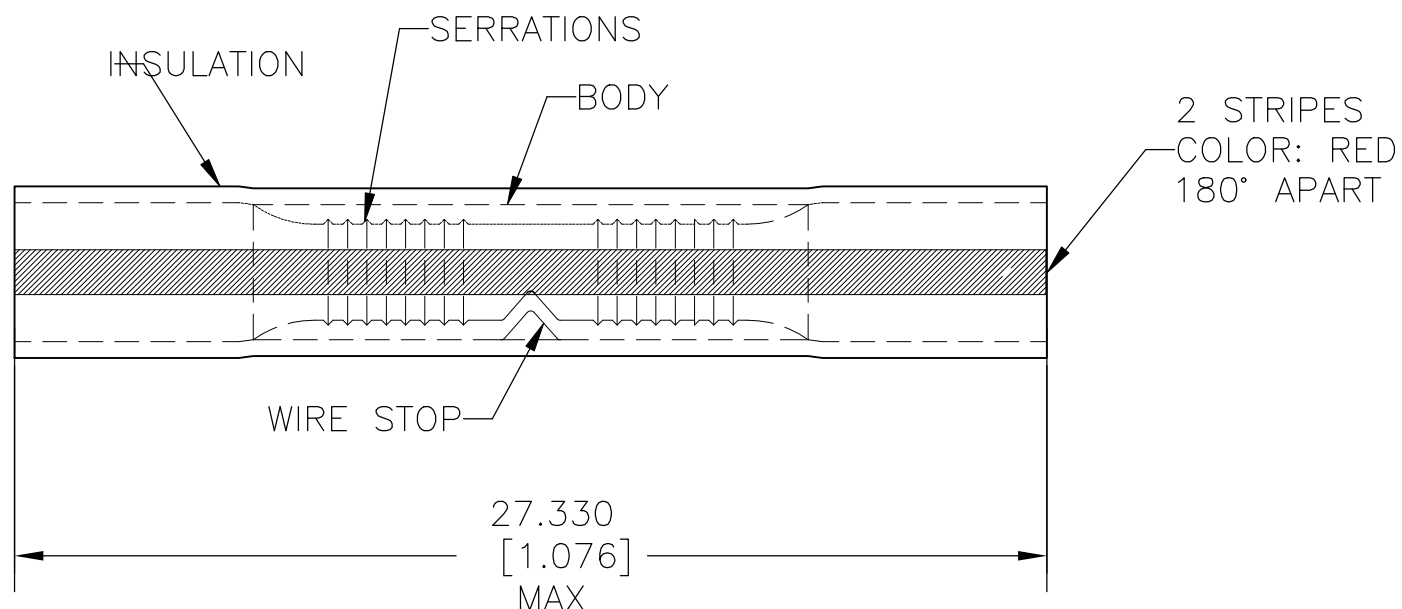

1. WIRE INSUL DIA, 2.667-3.556 [.105-.140]

2500	ON TAPE, REEL	BODY: COPPER PER ASTM B-152 TIN PL 0.00254[.000100] MIN THK PER ASTM B545	55792-2
1000	LOOSE PIECE	INSULATION: VINYL COLOR: TRANSPARENT	55792-1
QTY	PACKAGE TYPE	MATERIAL & FINISH	PART NO

THIS DRAWING IS A CONTROLLED DOCUMENT.		DWN DK SCHRUM 9/14/90	 <b>TE Connectivity Ltd.</b>											
DIMENSIONS: mm [INCHES]		CHK MS FEHER 9/14/90												
TOLERANCES UNLESS OTHERWISE SPECIFIED:		APVD TL SHUTTER 9/14/90	NAME SPLICE, BUTT, PLASTI-GRIP, WIRE SIZE, 22-16 AWG											
<table border="0"> <tr><td>0 PLC</td><td>± -</td></tr> <tr><td>1 PLC</td><td>± -</td></tr> <tr><td>2 PLC</td><td>± -</td></tr> <tr><td>3 PLC</td><td>± .127[.005]</td></tr> <tr><td>4 PLC</td><td>± -</td></tr> <tr><td>ANGLES</td><td>± -</td></tr> </table>		0 PLC			± -	1 PLC	± -	2 PLC	± -	3 PLC	± .127[.005]	4 PLC	± -	ANGLES
0 PLC	± -													
1 PLC	± -													
2 PLC	± -													
3 PLC	± .127[.005]													
4 PLC	± -													
ANGLES	± -													
MATERIAL SEE TABLE		FINISH SEE TABLE	APPLICATION SPEC 114-2161	SIZE A3	CAGE CODE 00779	DRAWING NO C-55792	RESTRICTED TO -							
CUSTOMER DRAWING			WEIGHT	SCALE 5:1	SHEET 1 OF 1	REV E1								