

MOLEX PN	ENGINEERING NO.	L+Tol. [mm]
1300068219	104006B35M005	500+45

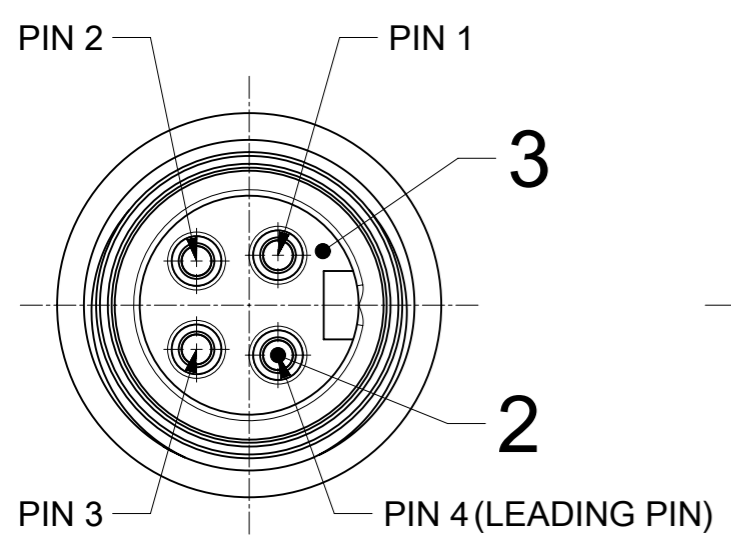

VIEW FROM THE FRONT SIDE

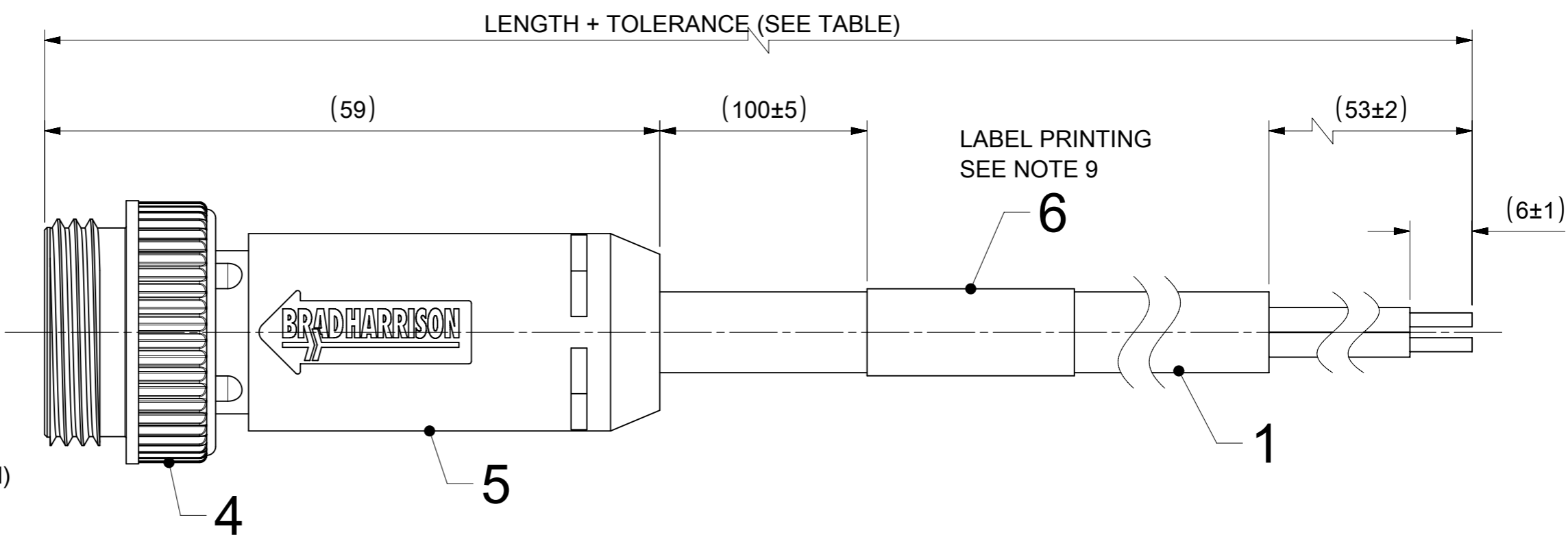

- NOTES:
1. MATERIAL: AS NOTED
 2. FINISH: AS NOTED
 3. ELECTRICAL:
VOLTAGE: 600 V
CURRENT: 10 A
 4. TEMPERATURE RATING:
STATIC: -40 °C TO 90 °C
DYNAMIC: -25 °C TO 80 °C
 5. PROTECTION: IP67 (WHEN MATED)
 6. UL CERTIFICATION: UL LISTED, FILE NO. E152210
 7. UV RESISTANCE: YES (UL1581/2556-300h)
 8. HOMOLOGATION: UL STYLE 21215 + CSA; RATING 80°C 600V
 9. LABEL PRINTING ACC. STANDARD LABEL INSTRUCTION

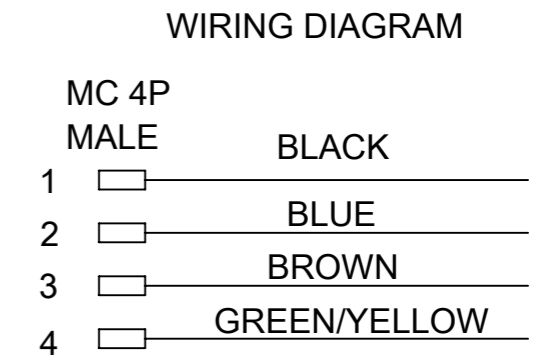
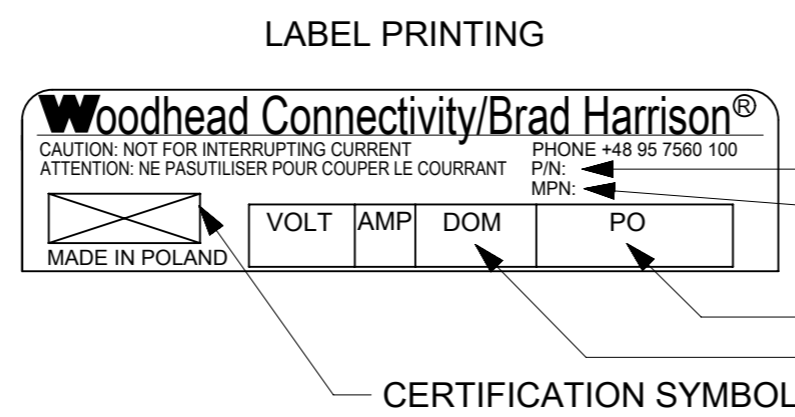

BILL OF MATERIAL

ITEM	QTY	DESCRIPTION	MATERIAL	FINISH/COLOR
1	-	CABLE #16-4, OD=7.8MM,WSR	TPU	GRAY
2	4	MALE CONTACT	BRASS	GOLD OVER NICKEL
3	1	MALE INSERT	TPE	BLACK
4	1	COUPLING NUT	ZINC DIE-CAST	BLACK E-COAT
5	-	MOULDING MATERIAL	TPE	BLACK
6	1	LABEL	VINYL	YELLOW

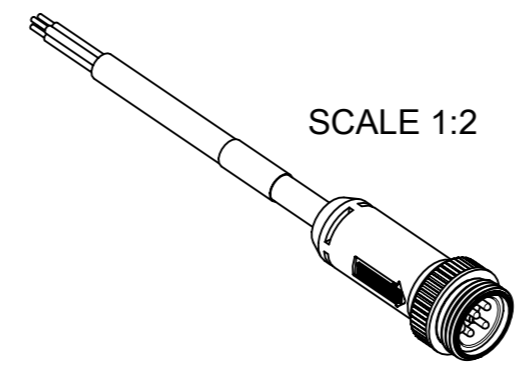

FUNCTIONAL SYMBOLS	THIS DRAWING CONTAINS INFORMATION THAT IS PROPRIETARY TO MOLEX ELECTRONIC TECHNOLOGIES, LLC AND SHOULD NOT BE USED WITHOUT WRITTEN PERMISSION		CURRENT REV DESC: NOTES UPDATED, LABEL PRINTING ADDED			
	SCALE	2:1				
DIVISIONAL SYMBOLS	GENERAL TOLERANCES (UNLESS SPECIFIED)		EC NO: 747270		2023/04/19	
	ANGULAR TOL ± 1.0 °		DRWN: RSCHIEBER		2023/04/27	
	4 PLACES ±		CHK'D: RSILLER		2023/04/27	
	3 PLACES ±		APPR: RSILLER		2023/04/27	
2 PLACES ± 0.05		INITIAL REVISION:		DOCUMENT NUMBER		
1 PLACE ± 0.3		DRWN: AKABADI		1300068219		
0 PLACES ± 0.5		APPR: RSILLER		DOC TYPE DOC PART REVISION		
DRAFT WHERE APPLICABLE MUST REMAIN WITHIN DIMENSIONS		THIRD ANGLE PROJECTION		PSD 000 A1		
		DRAWING		SHEET NUMBER		
		A3-SIZE		1 OF 1		
		SERIES		MATERIAL NUMBER		
		130006		SEE TABLE		
		CUSTOMER		GENERAL MARKET		

DOCUMENT STATUS	P1	RELEASE DATE	2023/04/27	12:11:47
-----------------	----	--------------	------------	----------