

# MC10H642, MC100H642

## 68030/040 PECL to TTL Clock Driver

### Description

The MC10H/100H642 generates the necessary clocks for the 68030, 68040 and similar microprocessors. It is guaranteed to meet the clock specifications required by the 68030 and 68040 in terms of part-to-part skew, within-part skew and also duty cycle skew.

The user has a choice of using either TTL or PECL (ECL referenced to +5.0 V) for the input clock. TTL clocks are typically used in present MPU systems. However, as clock speeds increase to 50 MHz and beyond, the inherent superiority of ECL (particularly differential ECL) as a means of clock signal distribution becomes increasingly evident. The H642 also uses differential PECL internally to achieve its superior skew characteristic.

The H642 includes divide-by-two and divide-by-four stages, both to achieve the necessary duty cycle skew and to generate MPU clocks as required. A typical 50 MHz processor application would use an input clock running at 100 MHz, thus obtaining output clocks at 50 MHz and 25 MHz (see Logic Diagram).

The 10H version is compatible with MECL 10H™ ECL logic levels, while the 100H version is compatible with 100K levels (referenced to +5.0 V).

### Features

- Generates Clocks for 68030/040
- Meets 030/040 Skew Requirements
- TTL or PECL Input Clock
- Extra TTL and PECL Power/Ground Pins
- Asynchronous Reset
- Single +5.0 V Supply
- Pb-Free Packages are Available\*

### Function

*Reset(R)*: LOW on RESET forces all Q outputs LOW.

*Select(SEL)*: LOW selects the ECL input source ( $\overline{DE}/\overline{DE}$ ). HIGH selects the TTL input source (DT).

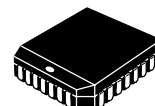
The H642 also contains circuitry to force a stable input state of the ECL differential input pair, should both sides be left open. In this Case, the DE side of the input is pulled LOW, and  $\overline{DE}$  goes HIGH.

*Power Up*: The device is designed to have positive edges of the  $\pm 2$  and  $\pm 4$  outputs synchronized at Power Up.



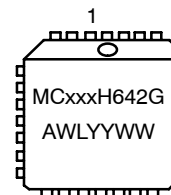
ON Semiconductor®

<http://onsemi.com>



PLCC-28  
FN SUFFIX  
CASE 776

### MARKING DIAGRAM\*



xxx	= 10 or 100
A	= Assembly Location
WL	= Wafer Lot
YY	= Year
WW	= Work Week
G	= Pb-Free Package

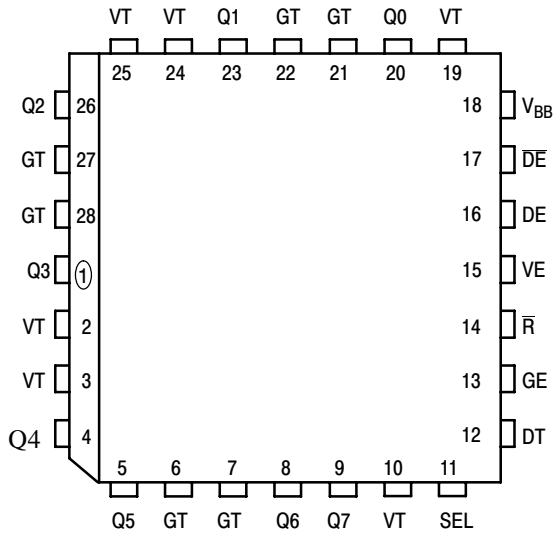
\*For additional marking information, refer to Application Note AND8002/D.

### ORDERING INFORMATION

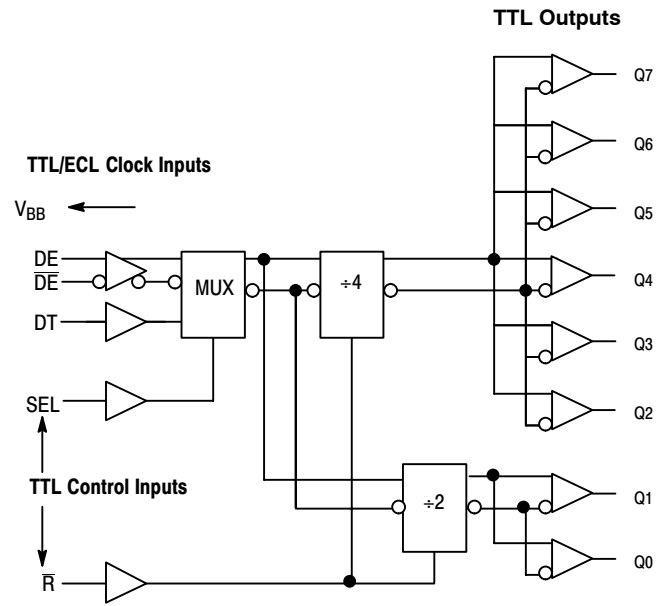
See detailed ordering and shipping information in the package dimensions section on page 8 of this data sheet.

\*For additional information on our Pb-Free strategy and soldering details, please download the ON Semiconductor Soldering and Mounting Techniques Reference Manual, SOLDERRM/D.

# MC10H642, MC100H642



**Figure 1. Pinout: PLCC-28**  
(Top View)



**Figure 2. Logic Diagram**

**Table 1. PIN DESCRIPTION**

Pin	Symbol	Description	Pin	Symbol	Description
1	Q3	Signal Output (TTL)**	15	VE	ECL V <sub>CC</sub> (+5.0 V)
2	VT	TTL V <sub>CC</sub> (+5.0 V)	16	DE	ECL Signal Input (Non-Inverting)
3	VT	TTL V <sub>CC</sub> (+5.0 V)	17	DE	ECL Signal Input (Inverting)
4	Q4	Signal Output (TTL)**	18	V <sub>BB</sub>	V <sub>BB</sub> Reference Output
5	Q5	Signal Output (TTL)**	19	VT	TTL V <sub>CC</sub> (+5.0 V)
6	GT	TTL Ground (0 V)	20	Q0	Signal Output (TTL)*
7	GT	TTL Ground (0 V)	21	GT	TTL Ground (0 V)
8	Q6	Signal Output (TTL)**	22	GT	TTL Ground (0 V)
9	Q7	Signal Output (TTL)**	23	Q1	Signal Output (TTL)*
10	VT	TTL V <sub>CC</sub> (+5.0 V)	24	VT	TTL V <sub>CC</sub> (+5.0 V)
11	SEL	Input Select (TTL)	25	VT	TTL V <sub>CC</sub> (+5.0 V)
12	DT	TTL Signal Input	26	Q2	Signal Output (TTL)**
13	GE	ECL Ground (0 V)	27	GT	TTL Ground (0 V)
14	R	Reset (TTL)	28	GT	TTL Ground (0 V)

\* Divide by 2

\*\*Divide by 4

## MC10H642, MC100H642

**Table 2. 10H PECL CHARACTERISTICS** ( $V_T = V_E = 5.0\text{ V} \pm 5\%$ )

Symbol	Characteristic	Condition	$T_A = 0^\circ\text{C}$		$T_A = 25^\circ\text{C}$		$T_A = 85^\circ\text{C}$		Unit
			Min	Max	Min	Max	Min	Max	
$I_{INH}$ $I_{INL}$	Input HIGH Current Input LOW Current		0.5	255	0.5	175	0.5	175	$\mu\text{A}$
$V_{IH}$ $V_{IL}$	Input HIGH Voltage (Note 1) Input LOW Voltage (Note 1)	$V_{EE} = 5.0\text{ V}$	3.83 3.05	4.16 3.52	3.87 3.05	4.19 3.52	3.94 3.05	4.28 3.555	V
$V_{BB}$	Output Reference Voltage (Note 1)		3.62	3.73	3.65	3.75	3.69	3.81	V

NOTE: Device will meet the specifications after thermal equilibrium has been established when mounted in a test socket or printed circuit board with maintained transverse airflow greater than 500 lfpm. Electrical parameters are guaranteed only over the declared operating temperature range. Functional operation of the device exceeding these conditions is not implied. Device specification limit values are applied individually under normal operating conditions and not valid simultaneously.

1. PECL LEVELS are referenced to  $V_{CC}$  and will vary 1:1 with the power supply. The VALUES shown are for  $V_{CC} = 5.0\text{ V}$ .

**Table 3. 100H PECL CHARACTERISTICS** ( $V_T = V_E = 5.0\text{ V} \pm 5\%$ )

Symbol	Characteristic	Condition	$T_A = 0^\circ\text{C}$		$T_A = 25^\circ\text{C}$		$T_A = 85^\circ\text{C}$		Unit
			Min	Max	Min	Max	Min	Max	
$I_{INH}$ $I_{INL}$	Input HIGH Current Input LOW Current		0.5	255	0.5	175	0.5	175	$\mu\text{A}$
$V_{IH}$ $V_{IL}$	Input HIGH Voltage (Note 2) Input LOW Voltage (Note 2)	$V_{EE} = 5.0\text{ V}$	3.835 3.190	4.120 3.525	3.835 3.190	4.120 3.525	3.835 3.190	4.120 3.525	V
$V_{BB}$	Output Reference Voltage (Note 2)		3.620	3.740	3.620	3.740	3.620	3.740	V

NOTE: Device will meet the specifications after thermal equilibrium has been established when mounted in a test socket or printed circuit board with maintained transverse airflow greater than 500 lfpm. Electrical parameters are guaranteed only over the declared operating temperature range. Functional operation of the device exceeding these conditions is not implied. Device specification limit values are applied individually under normal operating conditions and not valid simultaneously.

2. PECL LEVELS are referenced to  $V_{CC}$  and will vary 1:1 with the power supply. The VALUES shown are for  $V_{CC} = 5.0\text{ V}$ .

**Table 4. 10H/100H DC CHARACTERISTICS** ( $V_T = V_E = 5.0\text{ V} \pm 5\%$ )

Symbol	Characteristic		Condition	$T_A = 0^\circ\text{C}$		$T_A = 25^\circ\text{C}$		$T_A = 85^\circ\text{C}$		Unit
				Min	Max	Min	Max	Min	Max	
$I_{EE}$	Power Supply Current	PECL	$V_E$ Pin		57		57		57	mA
$I_{CCH}$		TTL	Total All VT Pins		30		30		30	mA
$I_{CCL}$					30		30		30	mA

NOTE: Device will meet the specifications after thermal equilibrium has been established when mounted in a test socket or printed circuit board with maintained transverse airflow greater than 500 lfpm. Electrical parameters are guaranteed only over the declared operating temperature range. Functional operation of the device exceeding these conditions is not implied. Device specification limit values are applied individually under normal operating conditions and not valid simultaneously.

# MC10H642, MC100H642

**Table 5. 10H/100H TTL DC CHARACTERISTICS** ( $V_T = V_E = 5.0\text{ V} \pm 5\%$ )

Symbol	Characteristic	Condition	$T_A = 0^\circ\text{C}$		$T_A = 25^\circ\text{C}$		$T_A = 85^\circ\text{C}$		Unit
			Min	Max	Min	Max	Min	Max	
$V_{IH}$ $V_{IL}$	Input HIGH Voltage Input LOW Voltage		2.0	0.8	2.0	0.8	2.0	0.8	V
$I_{IH}$	Input HIGH Current	$V_{IN} = 2.7\text{ V}$ $V_{IN} = 7.0\text{ V}$		20 100		20 100		20 100	$\mu\text{A}$
$I_{IL}$	Input LOW Current	$V_{IN} = 0.5\text{ V}$		-0.6		-0.6		-0.6	mA
$V_{OH}$	Output HIGH Voltage	$I_{OH} = -3.0\text{ mA}$ $I_{OH} = -15\text{ mA}$	2.5 2.0		2.5 2.0		2.5 2.0		V
$V_{OL}$	Output LOW Voltage	$I_{OL} = 24\text{ mA}$		0.5		0.5		0.5	V
$V_{IK}$	Input Clamp Voltage	$I_{IN} = -18\text{ mA}$		-1.2		-1.2		-1.2	V
$I_{OS}$	Output Short Circuit Current	$V_{OUT} = 0\text{ V}$	-100	-225	-100	-225	-100	-225	mA

NOTE: Device will meet the specifications after thermal equilibrium has been established when mounted in a test socket or printed circuit board with maintained transverse airflow greater than 500 lfm. Electrical parameters are guaranteed only over the declared operating temperature range. Functional operation of the device exceeding these conditions is not implied. Device specification limit values are applied individually under normal operating conditions and not valid simultaneously.

**Table 6. AC CHARACTERISTICS** ( $V_T = V_E = 5.0\text{ V} \pm 5\%$ )

Symbol	Characteristic	Condition	$T_A = 0^\circ\text{C}$		$T_A = 25^\circ\text{C}$		$T_A = 85^\circ\text{C}$		Unit			
			Min	Max	Min	Max	Min	Max				
$t_{PLH}$	Propagation Delay D to Output	Q2-Q7 C ECL C TTL	CL = 25 pF	4.70 4.70	5.70 5.70	4.75 4.75	5.75 5.75	4.60 4.50	5.60 5.50	ns		
$tskpp$	Part-to-Part Skew				1.0		1.0		1.0		ns	
$tskwd^*$	Within-Device Skew				0.5		0.5		0.5		ns	
$t_{PLH}$	Propagation Delay D to Output	Q0, Q1 C ECL C TTL	CL = 25 pF	4.30 4.30	5.30 5.30	4.50 4.50	5.50 5.50	4.25 4.25	5.25 5.25	ns		
$tskpp$	Part-to-Part Skew	All Outputs		CL = 25 pF		2.0		2.0			2.0	ns
$tskwd$	Within-Device Skew				CL = 25 pF		1.0		1.0			
$t_{PD}$	Propagation Delay R to Output	All Outputs	CL = 25 pF	4.3	6.3	4.0	6.0	4.5	6.5	ns		
$t_R$ $t_F$	Output Rise/Fall Time 0.8 V to 2.0 V	All Outputs		CL = 25 pF		2.5 2.5		2.5 2.5			2.5 2.5	ns
$f_{MAX}^{**}$	Maximum Input Frequency			CL = 25 pF	100		100		100			
RPW	Reset Pulse Width			1.5		1.5		1.5		ns		
RRT	Reset Recovery Time			1.25		1.25		1.25		ns		

NOTE: Device will meet the specifications after thermal equilibrium has been established when mounted in a test socket or printed circuit board with maintained transverse airflow greater than 500 lfm. Electrical parameters are guaranteed only over the declared operating temperature range. Functional operation of the device exceeding these conditions is not implied. Device specification limit values are applied individually under normal operating conditions and not valid simultaneously.

\* Within-Device Skew defined as identical transactions on similar paths through a device.

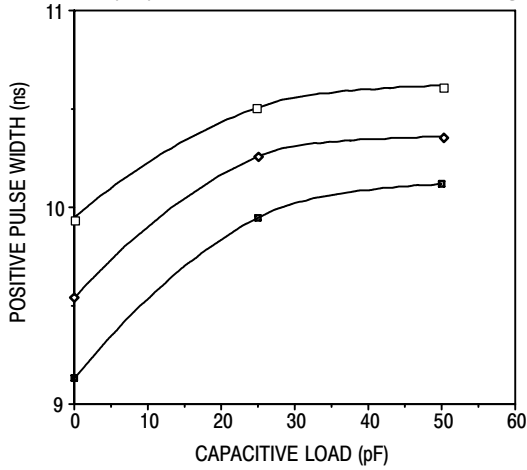
\*\*MAX Frequency is 135 MHz.

# MC10H642, MC100H642

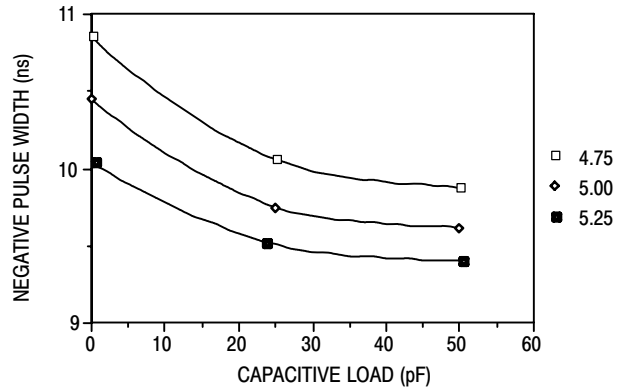
## 10/100H642 – DUTY CYCLE CONTROL

To maintain a duty cycle of  $\pm 5\%$  at 50 MHz, limit the load capacitance and/or power supply variation as shown in Figures 1 and 2. For a  $\pm 2.5\%$  duty cycle limit, see Figures 3 and 4. Figures 5 and 6 show duty cycle variation with temperature. Figure 7 shows typical TPD versus load. Figure 8 shows reset recovery time. Figure 9 shows output states after power up.

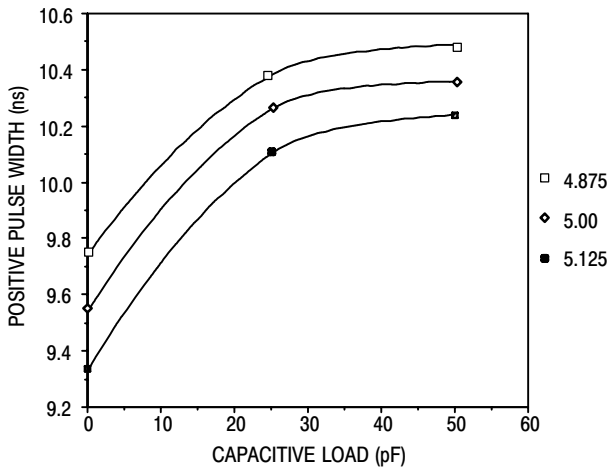
Best duty cycle control is obtained with a single  $\mu\text{P}$  load and minimum line length.



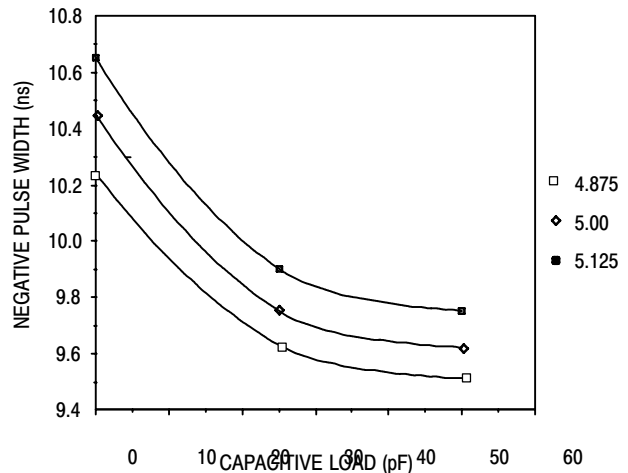
**Figure 3. MC10H642 Positive PW versus Load**  
@  $\pm 5\% V_{CC}$ ,  $T_A = 25^\circ\text{C}$



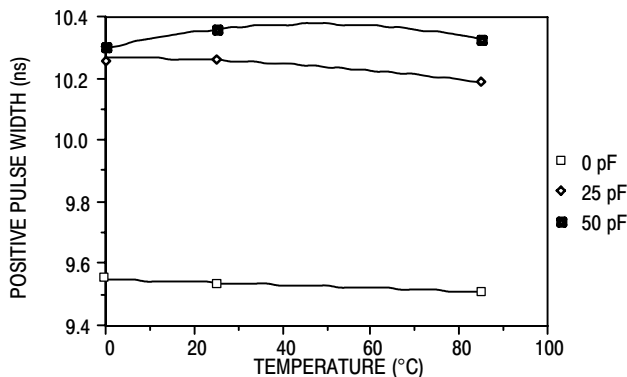
**Figure 4. MC10H642 Negative PW versus Load**  
@  $\pm 5\% V_{CC}$ ,  $T_A = 25^\circ\text{C}$



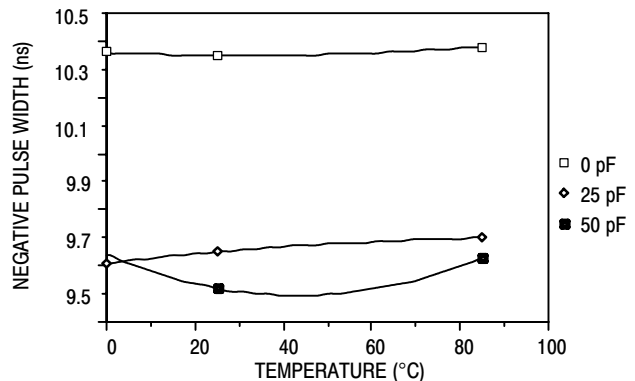
**Figure 5. MC10H642 Positive PW versus Load**  
@  $\pm 2.5\% V_{CC}$ ,  $T_A = 25^\circ\text{C}$



**Figure 6. MC10H642 Negative PW versus Load**  
@  $\pm 2.5\% V_{CC}$ ,  $T_A = 25^\circ\text{C}$

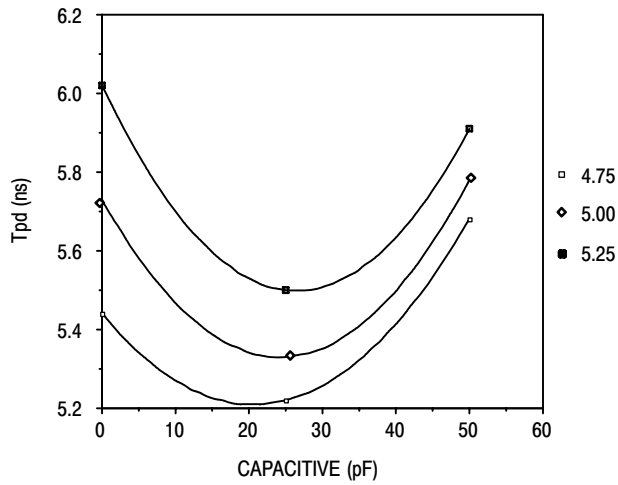


**Figure 7. MC10H642 Positive PW versus Temperature,**  
 $V_{CC} = 5.0\text{ V}$

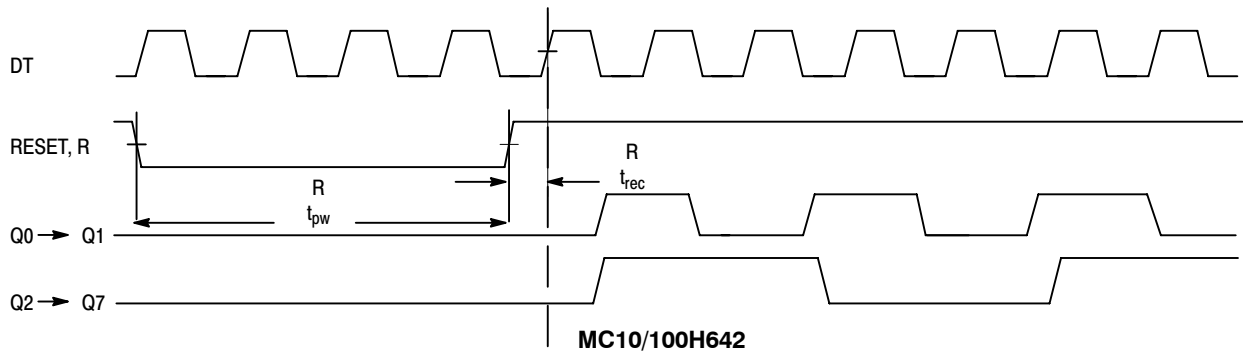


**Figure 8. MC10H642 Negative PW versus Temperature,**  
 $V_{CC} = 5.0\text{ V}$

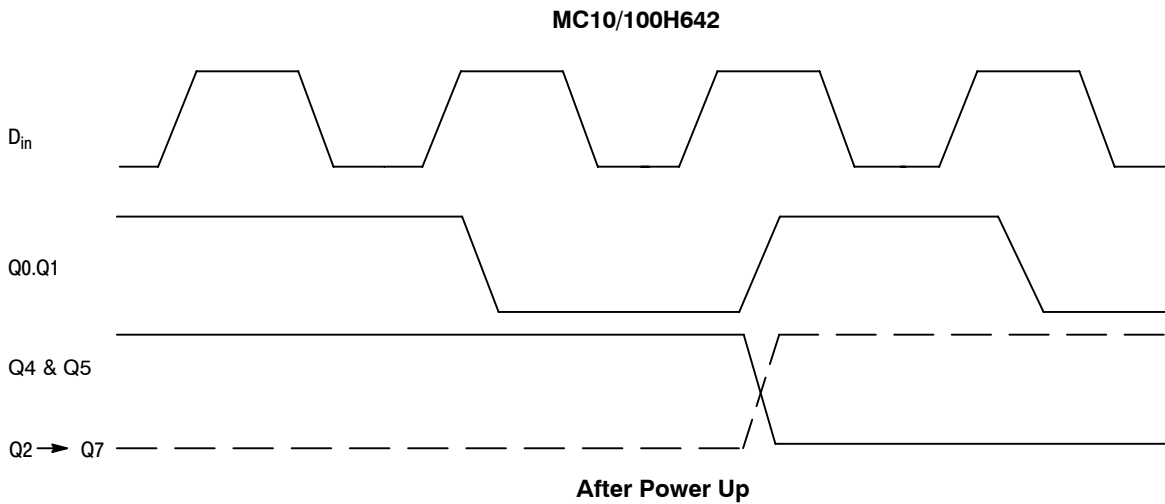
# MC10H642, MC100H642



**Figure 9. MC10H642 + Tpd versus Load,  $V_{CC} \pm 5\%$ ,  $T_A = 25^\circ C$  (Overshoot at 50 MHz with no load makes graph non linear)**



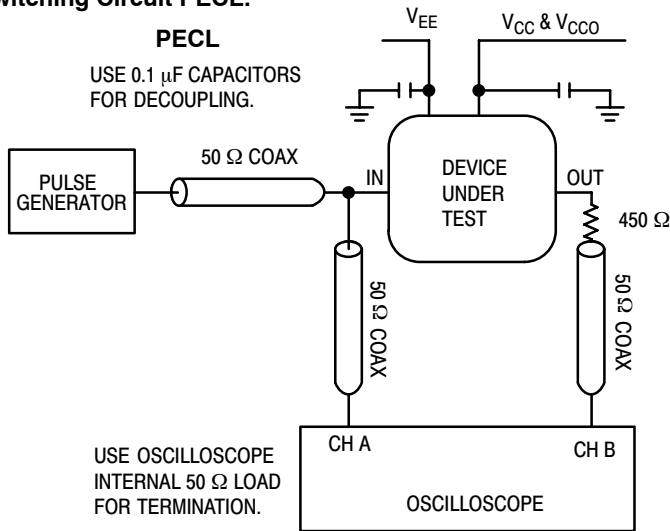
**Figure 10. Clock Phase and Reset Recovery Time After Reset Pulse**



**Figure 11. Outputs** Q2 → Q7 will Synchronize with Pos Edges of  $D_{in}$  & Q0 → Q1

# MC10H642, MC100H642

## Switching Circuit PECL:



## TTL

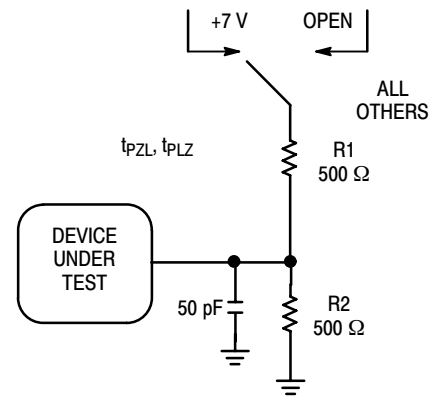


Figure 12. Switching Circuit and Waveforms

## PECL/TTL



Figure 14. Waveforms: Rise and Fall Times

## PECL/TTL

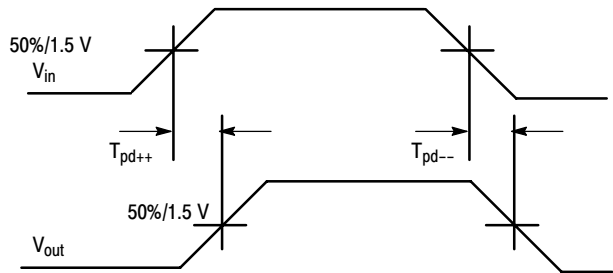


Figure 13. Propagation Delay — Single-Ended

# MC10H642, MC100H642

## ORDERING INFORMATION

Device	Package	Shipping†
MC10H642FN	PLCC-28	37 Units / Rail
MC10H642FNG	PLCC-28 (Pb-Free)	37 Units / Rail
MC10H642FNR2	PLCC-28	500 / Tape & Reel
MC10H642FNR2G	PLCC-28 (Pb-Free)	500 / Tape & Reel
MC100H642FN	PLCC-28	37 Units / Rail
MC100H642FNG	PLCC-28 (Pb-Free)	37 Units / Rail
MC100H642FNR2	PLCC-28	500 / Tape & Reel
MC100H642FNR2G	PLCC-28 (Pb-Free)	500 / Tape & Reel

†For information on tape and reel specifications, including part orientation and tape sizes, please refer to our Tape and Reel Packaging Specifications Brochure, BRD8011/D.

### Resource Reference of Application Notes

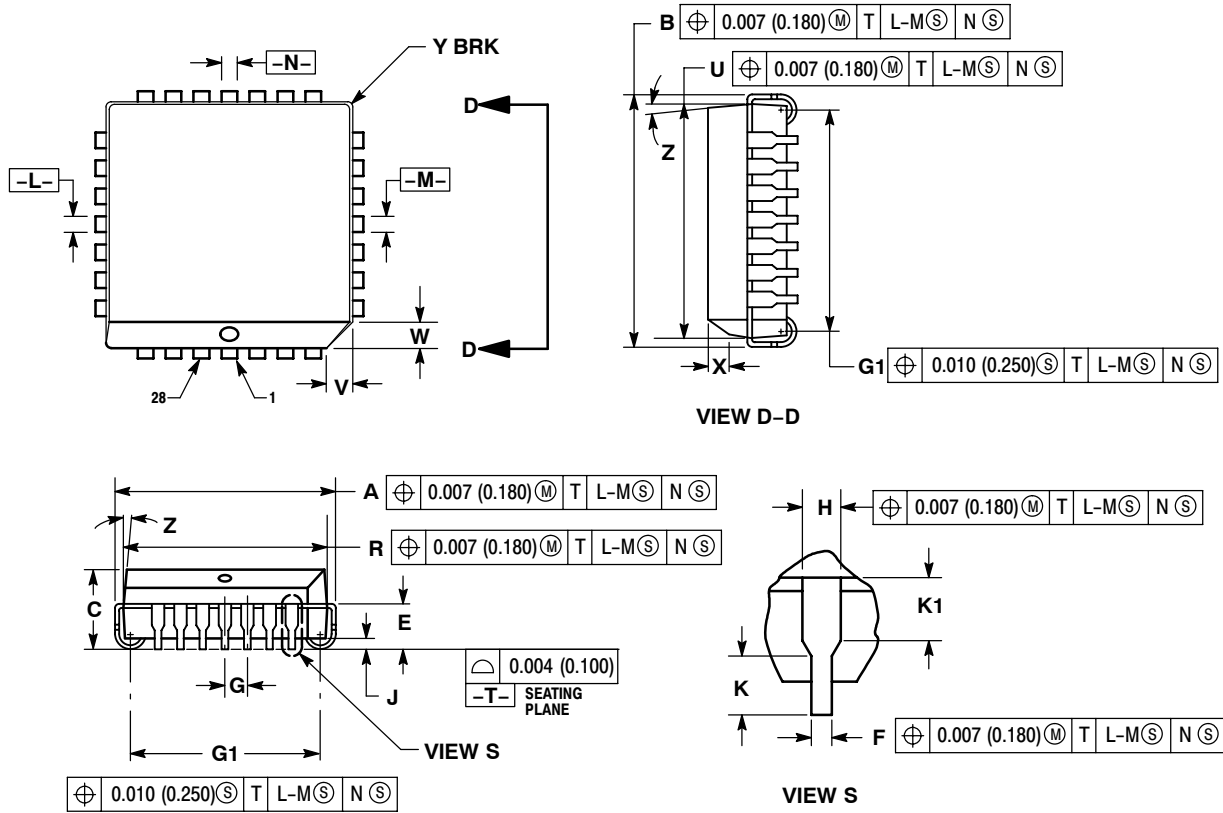
- AN1405/D** – ECL Clock Distribution Techniques
- AN1406/D** – Designing with PECL (ECL at +5.0 V)
- AN1503/D** – ECLinPS™ I/O SPICE Modeling Kit
- AN1504/D** – Metastability and the ECLinPS Family
- AN1568/D** – Interfacing Between LVDS and ECL
- AN1672/D** – The ECL Translator Guide
- AND8001/D** – Odd Number Counters Design
- AND8002/D** – Marking and Date Codes
- AND8020/D** – Termination of ECL Logic Devices
- AND8066/D** – Interfacing with ECLinPS
- AND8090/D** – AC Characteristics of ECL Devices



# MC10H642, MC100H642

## PACKAGE DIMENSIONS

PLCC-28  
FN SUFFIX  
PLASTIC PLCC PACKAGE  
CASE 776-02  
ISSUE E




**NOTES:**

- DATUMS -L-, -M-, AND -N- DETERMINED WHERE TOP OF LEAD SHOULDER EXITS PLASTIC BODY AT MOLD PARTING LINE.
- DIMENSION G1, TRUE POSITION TO BE MEASURED AT DATUM -T-, SEATING PLANE.
- DIMENSIONS R AND U DO NOT INCLUDE MOLD FLASH. ALLOWABLE MOLD FLASH IS 0.010 (0.250) PER SIDE.
- DIMENSIONING AND TOLERANCING PER ANSI Y14.5M, 1982.
- CONTROLLING DIMENSION: INCH.
- THE PACKAGE BOTTOM MAY BE SMALLER THAN THE PACKAGE TOP BY UP TO 0.012 (0.300). DIMENSIONS R AND U ARE DETERMINED AT THE OUTERMOST EXTREMES OF THE PLASTIC BODY EXCLUSIVE OF MOLD FLASH, TIE BAR BURRS, GATE BURRS AND INTERLEAD FLASH, BUT INCLUDING ANY MISMATCH BETWEEN THE TOP AND BOTTOM OF THE PLASTIC BODY.
- DIMENSION H DOES NOT INCLUDE DAMBAR PROTRUSION OR INTRUSION. THE DAMBAR PROTRUSION(S) SHALL NOT CAUSE THE H DIMENSION TO BE GREATER THAN 0.037 (0.940). THE DAMBAR INTRUSION(S) SHALL NOT CAUSE THE H DIMENSION TO BE SMALLER THAN 0.025 (0.635).

DIM	INCHES		MILLIMETERS	
	MIN	MAX	MIN	MAX
A	0.485	0.495	12.32	12.57
B	0.485	0.495	12.32	12.57
C	0.165	0.180	4.20	4.57
E	0.090	0.110	2.29	2.79
F	0.013	0.019	0.33	0.48
G	0.050 BSC		1.27 BSC	
H	0.026	0.032	0.66	0.81
J	0.020	---	0.51	---
K	0.025	---	0.64	---
R	0.450	0.456	11.43	11.58
U	0.450	0.456	11.43	11.58
V	0.042	0.048	1.07	1.21
W	0.042	0.048	1.07	1.21
X	0.042	0.056	1.07	1.42
Y	---	0.020	---	0.50
Z	2° 10°		2° 10°	
G1	0.410	0.430	10.42	10.92
K1	0.040	---	1.02	---

# MC10H642, MC100H642

ECLinPS is a trademark of Semiconductor Components Industries, LLC (SCILLC).  
MECL 10H is a trademark of Motorola, Inc.

**ON Semiconductor** and  are registered trademarks of Semiconductor Components Industries, LLC (SCILLC). SCILLC reserves the right to make changes without further notice to any products herein. SCILLC makes no warranty, representation or guarantee regarding the suitability of its products for any particular purpose, nor does SCILLC assume any liability arising out of the application or use of any product or circuit, and specifically disclaims any and all liability, including without limitation special, consequential or incidental damages. "Typical" parameters which may be provided in SCILLC data sheets and/or specifications can and do vary in different applications and actual performance may vary over time. All operating parameters, including "Typicals" must be validated for each customer application by customer's technical experts. SCILLC does not convey any license under its patent rights nor the rights of others. SCILLC products are not designed, intended, or authorized for use as components in systems intended for surgical implant into the body, or other applications intended to support or sustain life, or for any other application in which the failure of the SCILLC product could create a situation where personal injury or death may occur. Should Buyer purchase or use SCILLC products for any such unintended or unauthorized application, Buyer shall indemnify and hold SCILLC and its officers, employees, subsidiaries, affiliates, and distributors harmless against all claims, costs, damages, and expenses, and reasonable attorney fees arising out of, directly or indirectly, any claim of personal injury or death associated with such unintended or unauthorized use, even if such claim alleges that SCILLC was negligent regarding the design or manufacture of the part. SCILLC is an Equal Opportunity/Affirmative Action Employer. This literature is subject to all applicable copyright laws and is not for resale in any manner.

## PUBLICATION ORDERING INFORMATION

### LITERATURE FULFILLMENT:

Literature Distribution Center for ON Semiconductor  
P.O. Box 5163, Denver, Colorado 80217 USA  
**Phone:** 303-675-2175 or 800-344-3860 Toll Free USA/Canada  
**Fax:** 303-675-2176 or 800-344-3867 Toll Free USA/Canada  
**Email:** [orderlit@onsemi.com](mailto:orderlit@onsemi.com)

**N. American Technical Support:** 800-282-9855 Toll Free  
USA/Canada  
**Europe, Middle East and Africa Technical Support:**  
Phone: 421 33 790 2910  
**Japan Customer Focus Center**  
Phone: 81-3-5773-3850

**ON Semiconductor Website:** [www.onsemi.com](http://www.onsemi.com)  
**Order Literature:** <http://www.onsemi.com/orderlit>

For additional information, please contact your local  
Sales Representative