

8

7

6

5

4

3

2

1

VICOR CONFIDENTIAL

THIS DOCUMENT AND THE DATA DISCLOSED HEREIN OR HEREWITH IS NOT TO BE REPRODUCED, USED OR DISCLOSED IN WHOLE OR IN PART TO ANYONE WITHOUT THE PERMISSION OF VICOR CORP.

REVISIONS

REV	DESCRIPTION	DATE	APPROVED
1	RELEASED PER E0430434	09/16/04	FN
2	REVISED PER E090673C	04/22/09	REJH
3	REVISED PER E091595a	09/10/09	REJH
4	REVISED PER E101310b	10/22/10	AR
5	REVISED PER E111090	11/07/11	REJH

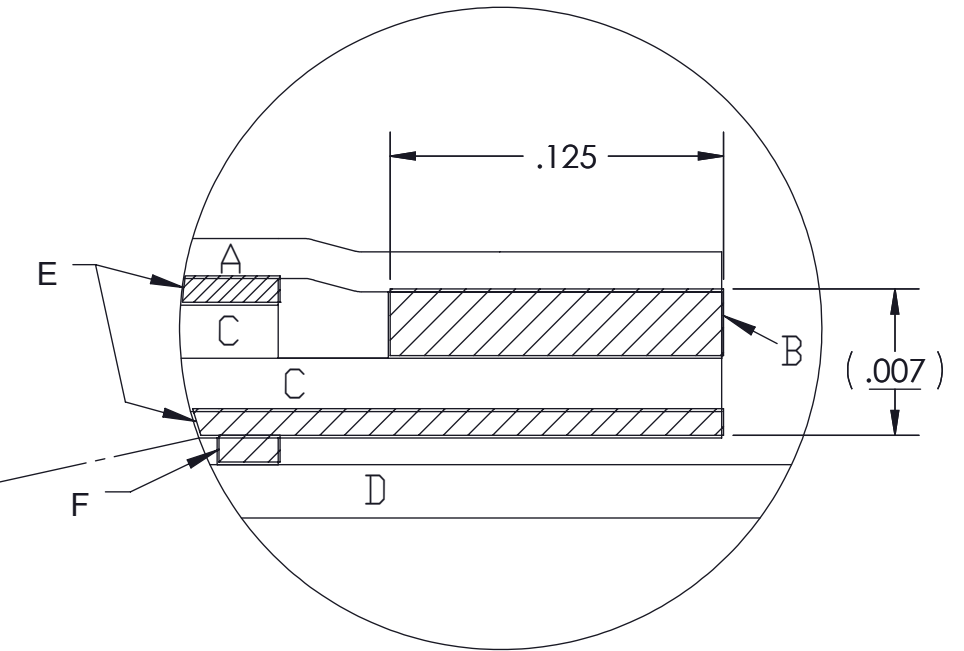
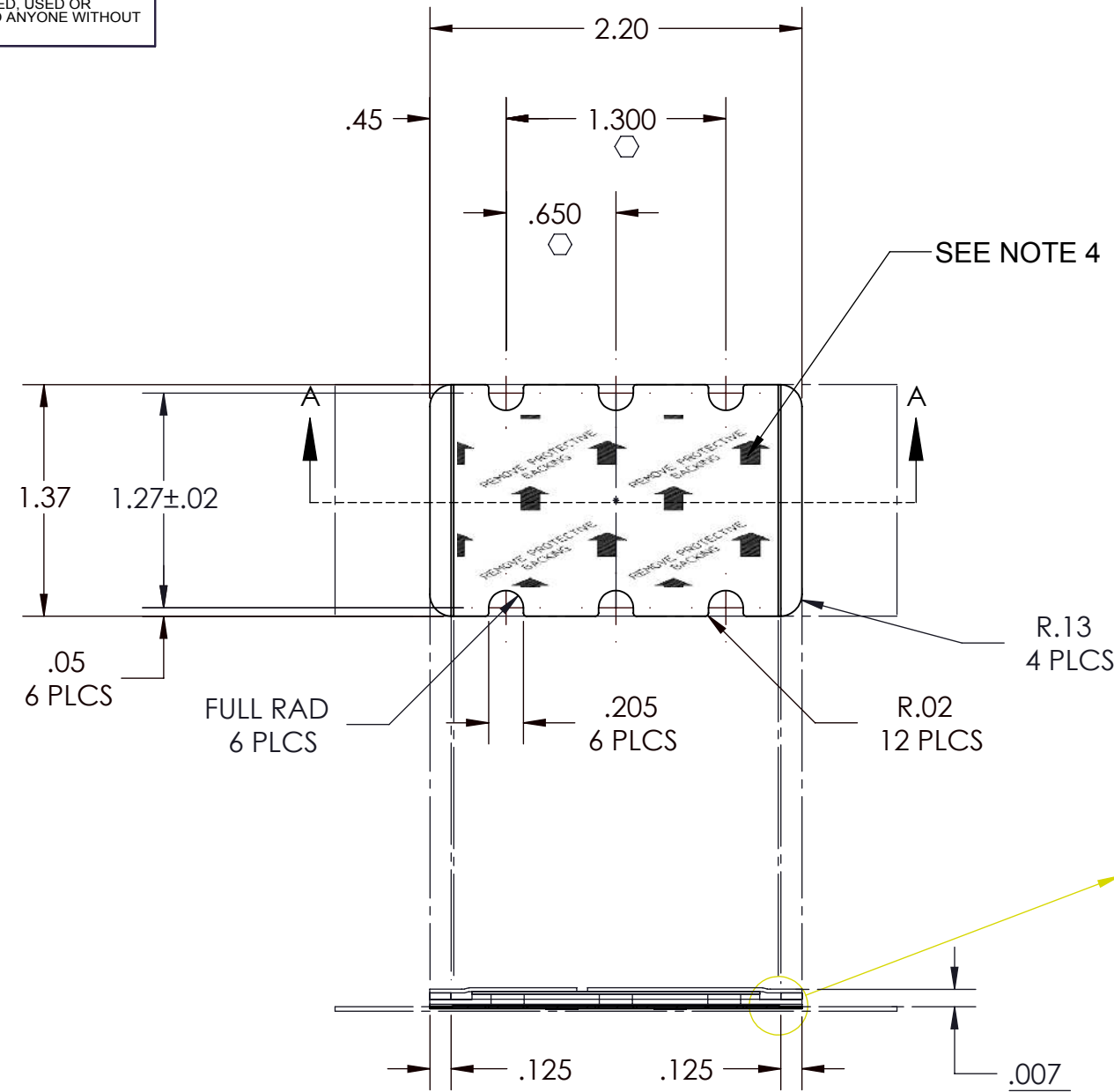

DETAIL :
 A. SPLIT RELEASE LINER.
 B. ADHESIVE STRIP; .0025 THICK .125 WIDE.
 C. ALUMINUM ALLOY 1145-0; .002 THICK.
 D. ROLL CARRIER WITH ADHESIVE STRIP BONDING.
 E. PHASE CHANGE THERMAL COMPOUND.
 F. ADHESIVE STRIPS ON ROLL CARRIER.

SECTION A-A
 (VERTICAL THICKNESS IS NOT SHOWN TO SCALE)

- NOTES:
1. MATERIAL: MAKE FROM HENKEL AL-2-22H-137
 2. THICKNESS: .007±.001.
 3. SEE DETAIL FOR ASSY ORDER.
 4. FOR ARTWORK SHOWN HERE SEE DWG# 20200.
 5. \square DENOTE CRITICAL CHARACTERISTIC FOR LOT INSPECTION.
 6. RoHS COMPLIANT PER CST-0001 LATEST REVISION.
 7. PRIOR TO ASSEMBLY, PRODUCTS SHALL BE STORED IN A COOL, DRY LOCATION IN ORIGINAL PACKAGING AT TEMPERATURES BELOW 40°C (104°F). UNDER THESE CONDITIONS THE SHELF LIFE IS INDEFINITE. THERMMATE PADS CAN BE PRE-APPLIED TO BASEPLATES OR HEAT SINKS WHICH ARE THEN SHIPPED TO A FINAL ASSEMBLY LOCATION, AS LONG AS THE TEMPERATURE DOES NOT EXCEED THE LEVEL INDICATED ABOVE.

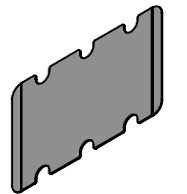

DRAWN	DATE				
J. RENAUD	2/13/97				
UNLESS OTHERWISE SPECIFIED DIMENSIONS ARE INCH [MM] TOLERANCES ARE: DECIMALS ANGLES X.XX [X.X] = ±0.01 [0.25] ±1° X.XXX [X.XX] = ±0.005 [0.127]		THERMAL INTERFACE PAD THERMATE® (MICRO) P/N 20265			
MATERIAL	FINISH	SIZE	CAGE CODE	DWG NO	REV
	THIRD ANGLE PROJECTION	B	67131	16192	5
DO NOT SCALE DRAWING		SCALE 1: 1	SHEET 1 OF 1		

8

7

6

5

4

3

2

1