

T31-INDUS Development Kit



EVALUATION-BOARD KIT

T31_INDUS is an AIoT application development kit based on the QFN package of T31. T31 has a Starlight Enhancement level ISP and a variety of peripheral interface. The T31_INDUS development kit helps customers to speed up their product development, it consists of development boards (core module, WIFI module and sensor board), an operating system and a SDK package. With an Ingenic's SoC T31 as the processor, the kit is featured with high performance compute capacity, real-time controller, large-volume on chip memory, a variety of multimedia processing ability as well as Megabit Ethernet networking and other connectivity options. The target applications are battery camera, mobile home monitoring camera, conferencing camera, dash camera, etc... Users can design and evaluate such solutions with the kit easily.

Open source operation system, drivers, programming tools and other software packages and documentation of hardware design are available. The core module is useful for R&D, and it is available as a standalone demo.

BENEFITS

- Open Source Hardware & Software - Hardware schematic diagram, PCB design, BOM, OS (Linux3.10, Linux4.4) and driver software packages.
- Core Module - With a design of stamp-holes, mass shipment is available.
- High Quality Multimedia Capacity - VPU with H.264 and H.265 encoding; digital and analog audio interfaces.
- Advanced Connectivity - Megabit Ethernet(compliant with IEEE1588- 2002), UART, ADC, I2C.
- Advanced AI development platform, known as "Magik"; typical AI algorithms available: smart tracking, person detection, baby cry detection, etc...

SYSTEM DIAGRAM

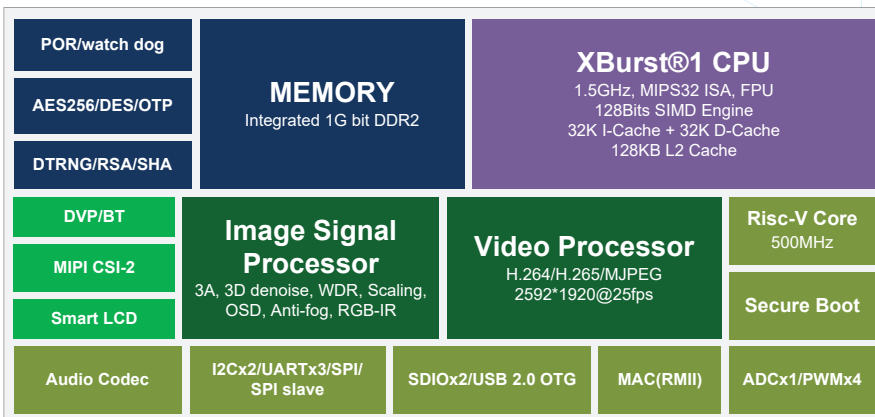

FEATURES

- Ingenic T31SoC, includes a 1.5GHz XBurst CPU core, with MIPS ISA, 128bit MXA, FPU and MMU(SIMD128 AI), 64kB data L1 cache, 128kB L2 cache.
- Memory: 512Mb or 1Gb DDR2 in chip, 16MB SPI NAND Flash, TF socket.
- Tiziano-II ISP engine, maximum 2592x1900 processing resolution, extremely low light enhanced.
- Camera Interface: Support DVP camera interface or MIPI-2lane or 4lane, up to 5M (2592*1900) @ 25fps.
- Advanced 2D/3D de-noise, 3A, DRC.
- MIC and Speaker on board.
- USB2.0(Micro-B), full speed and high-speed modes are supported, it can be used as host OTG also.
- USB-To-UART for debugging.
- Extension port for I2C/USB/SDIO/ADC.
- Power consumption: 400mW for 1080p@30fps H.265 streaming.
- Fastboot on Linux OS, less than 300ms.
- Low power modes: Idle, Sleep, Deep-sleep, Hibernation.
- Linux 3.10 with open source code, Linux 4.4 is also supported.
- Interrupt Controller, Watch Dog, System Timers, DMA, and PWM with timer and counter.
- 2 keys for user self-definition, 1 reset key and 1 key to select the booting mode of the system.

APPLICATION & SOLUTIONS

- Power consumption: The system is running on battery, then the power needs to be used wisely. T31 is always powered off, it will be powered on when an event is detected.
- Fast boot feature: This demo will save a number of frames in less than 300 ms in order to help the user knows what trigger the T31 to be powered on.
- Battery Camera/ Mobile home monitoring camera: Such cameras are mostly in sleep mode. They wake up when an event happens. They usually connect to network via wireless. Ex: Doorbell Camera, Hunting Camera, Portable Indoor/Outdoor Camera.

APPLICATION & SOLUTIONS

- Edge Deep Learning: Customers can have access to an AI platform (Magik Toolkit) and prebuilt algorithms (ADK) to help reduce the development time. These resources are not part of the SDK (Software Development Kit), but they can be released to customers after requesting them.
- AI platform (Magik Toolkit): Customers can use the AI platform to tune algorithms to work better in their application according to their requirements. To work with Magik, the customer should have considerable AI experience. Otherwise, a third party design house or ODM is recommended.
- Algorithm Development Kit (ADK): They are referred to as ADK (Algorithm Development Kit). The SDK and ADK can be combined to work on solutions, such as: Detection solutions - Human body detection, vehicle detection, human face detection, motion detection etc.; Recognition solutions - Plate recognition, facial recognition etc.

CORE MODULE IMAGE

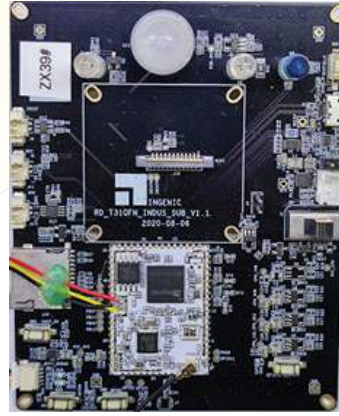

RD_T31QFN_INDUS_SUB_V1.1

ORDERING INFORMATION

EVK Part Number: **T31-INDUS-EB**

EVK Components:

- 1) RD_T31QFN_INDUS_SUB_V1.1 (1)
- 2) RD_HFJZ_GC2063_V1.0 (1)
- 3) MT7682 (soldered on core module)
- 4) RD_HFJZ_USBDEBUG_V1.1 (1)
- 5) Antenna (1)

SYSTEM ARCHITECTURE

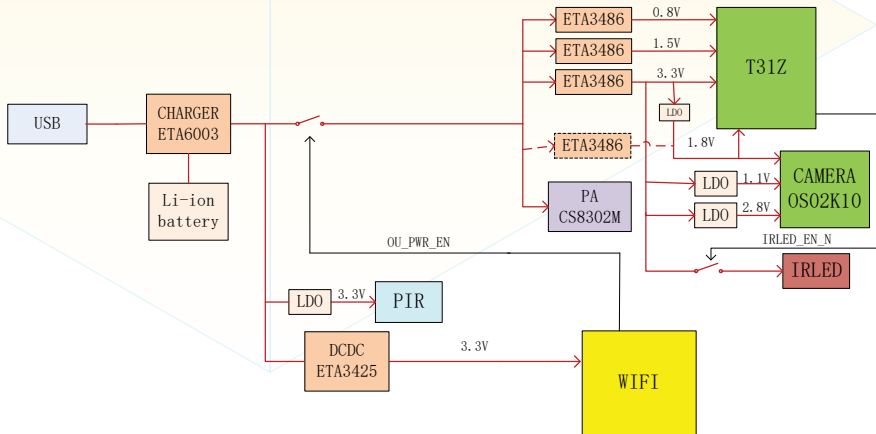

SENSOR BOARD IMAGE

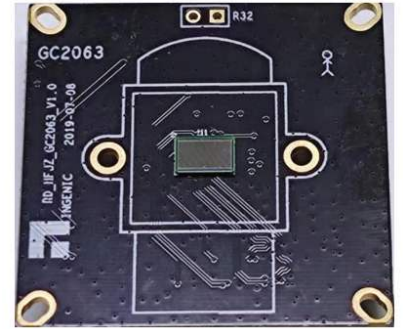

RD_HFJZ_GC2063_V1.0

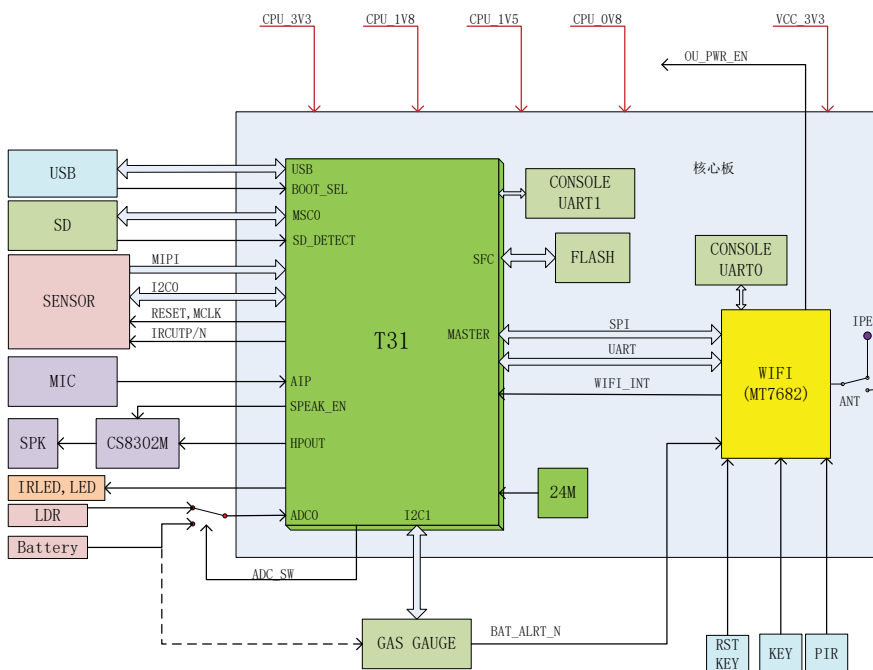

WIFI MODULE IMAGE

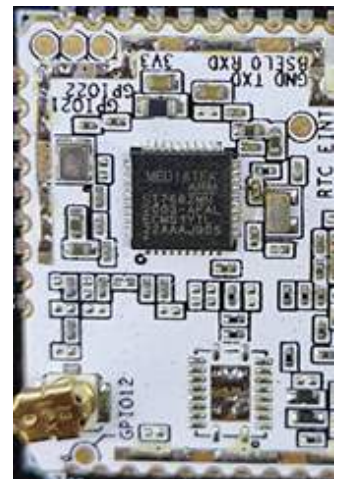

MT7682