

ESP8266-DevKitS

User Guide



Version 1.0
Espressif Systems
Copyright © 2020

About This Guide

This user guide provides information on ESP8266-DevKitS-development board.

Release Notes

Date	Version	Release notes
2020.02	V1.0	Initial release.

Documentation Change Notification

Espressif provides email notifications to keep customers updated on changes to technical documentation. Please subscribe [here](#).

Certification

Download certificates for Espressif products from [here](#).

Tables of Contents

1. Overview	1
2. Functional Description	2
3. How to Flash a Board	4
3.1. Hardware Preparation	4
3.2. Hardware Setup	4
3.3. Software Setup	4
4. Board Dimensions	5
5. Hardware Reference	6
5.1. Block Diagram.....	6
5.2. Power Supply Options	6
5.3. Header Blocks.....	6
A. Appendix—Learning Resources	8
A.1. Must-Read Documents	8
A.2. Must-Have Resources.....	9



1.

Overview

ESP8266-DevKitS is Espressif's flashing board designed specifically for ESP8266. It can be used to flash an ESP8266 module without soldering the module to the power supply and signal lines. With a module mounted, ESP8266-DevKitS can also be used as a mini development board like ESP8266-DevKitC.

ESP8266-DevKitS supports the following ESP8266 modules:

- ESP-WROOM-02
- ESP-WROOM-02D
- ESP-WROOM-02U



2. Functional Description

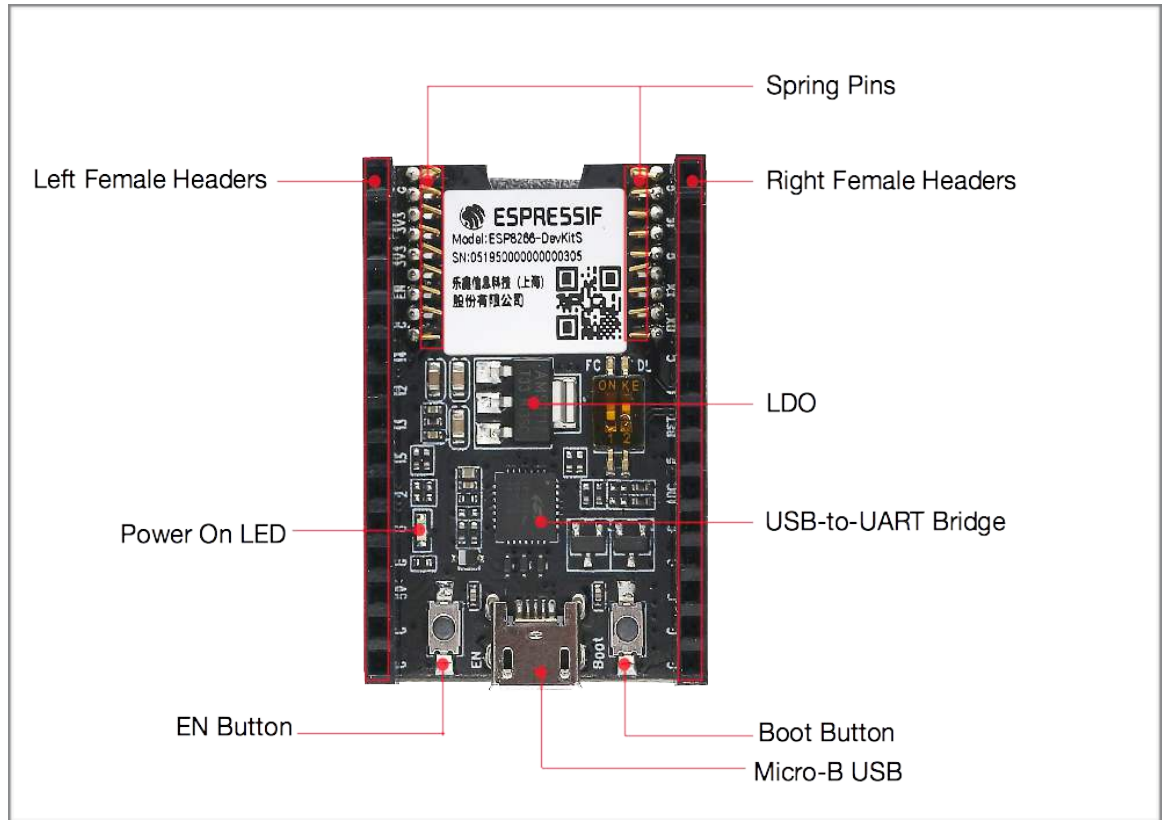

Figure 2-1. ESP8266-DevKitS

This chapter introduces key components, interfaces and controls of ESP8266-DevKitS development board:

- **Spring Pins**

Connect and fix the module. These spring pins fit castellated holes on the module.

- **2.54 mm Female Headers**

Connect to jumper wires and other development boards. For description of female headers, please refer to 5.3 Header Blocks.

- **USB-to-UART Bridge**

A single chip USB-UART bridge provides up to 3 Mbps transfers rates.



- **LDO**
5V-to-3.3V Low dropout voltage regulator (LDO).
- **Boot Button**
Download button. Holding down the Boot button and pressing the EN button initiates the firmware download mode. Then users can download firmware through the serial port.
- **Micro USB Port/Micro USB Connector**
USB interface. Power supply for the board and the communication interface between a computer and the board.
- **EN Button**
Reset button. Pressing this button resets the system.
- **Power On LED**
Turns on when the USB or power supply is connected to the board.



3. How to Flash a Board

3.1. Hardware Preparation

- 1 x ESP8266 module of your choice
- 1 x USB 2.0 cable (Standard-A to Micro-B)
- 1 x PC loaded with Windows, Linux or Mac OS

3.2. Hardware Setup

Please mount a module of your choice onto your ESP8266-DevKitS according to the following steps:

- Gently put your module on the ESP8266-DevKitS board. Make sure that castellated holes on your module are aligned with spring pins on the board.
- Press your module down into the board until it clicks.
- Check whether all spring pins are inserted into castellated holes. If there are some misaligned spring pins, place them into castellated holes with tweezers.

3.3. Software Setup

For step-by-step introductions, please refer to [ESP8266 Quick Start Guide](#).

 **Note:**

1. *To flash binary files, the ESP32 chip should be set to UART boot mode. This can be done either by the flash tool automatically, or by holding down the Boot button and tapping the EN button.*
2. *After binary files have been flashed, please reset or power up your ESP32 module again to run the flashed application (this step is executed automatically by the flash tool by default).*



4.

Board Dimensions

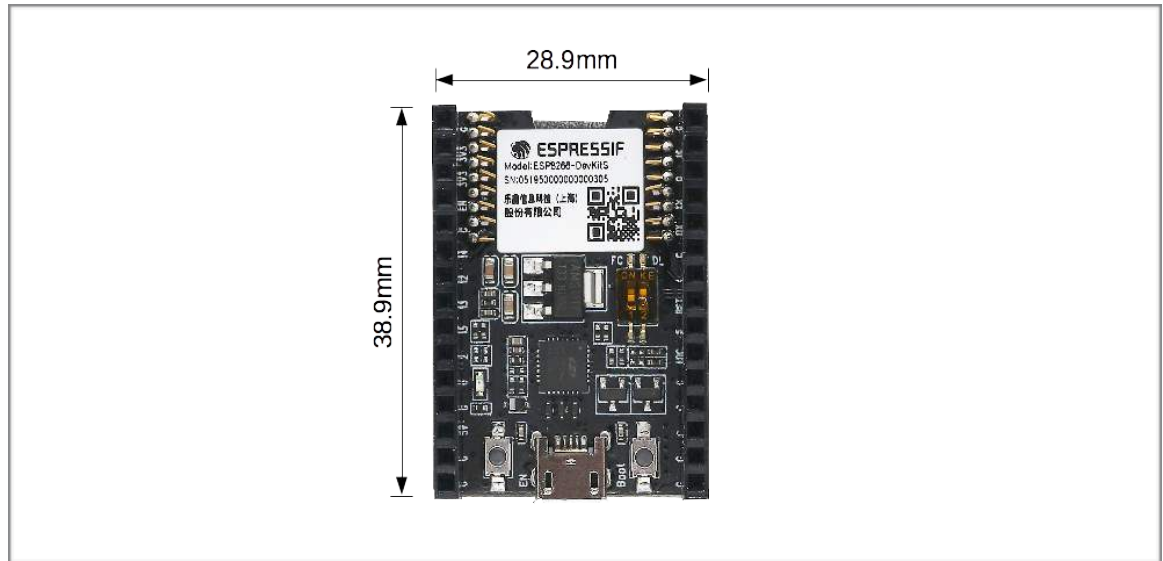

Figure 4-1. Board Dimensions



5. Hardware Reference

5.1. Block Diagram

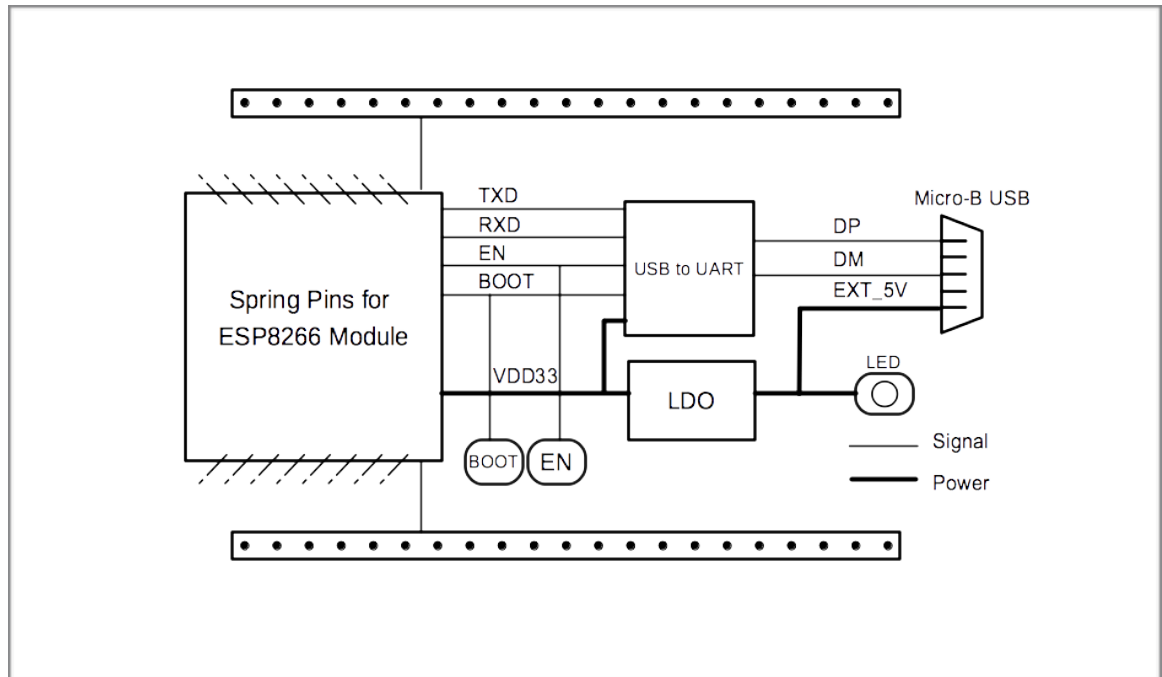

Figure 5-1. ESP8266-DevKitS Block Diagram

5.2. Power Supply Options

There are three mutually exclusive ways to provide power to the board:

- Micro USB port, default power supply
- 5V and GND header pins
- 3V3 and GND header pins

It is advised to use the first option: micro USB port.

5.3. Header Blocks

Table 5-1. Header Block

Location	Label	Signal
L1	G	GND
L2	3V3	VDD 3V3
L3	3V3	VDD 3V3



L4	EN	CHIP_EN
L5	G	GND
L6	14	GPIO14
L7	12	GPIO12
L8	13	GPIO13
L9	15	GPIO15
L10	2	GPIO2
L11	0	GPIO0
L12	G	GND
L13	5V	External 5V
L14	G	GND
L15	G	GND
R1	G	GND
R2	16	GPIO16
R3	G	GND
R4	TX	U0TXD
R5	RX	U0RXD
R6	G	GND
R7	4	GPIO4
R8	RST	EXT_RSTB
R9	5	GPIO5
R10	ADC	To TOUT after a voltage divider
R11	G	GND
R12	G	GND
R13	G	GND
R14	G	GND
R15	G	GND



A. Appendix – Learning Resources

A.1. Must-Read Documents

- [*ESP8266-DevKitS Reference Design*](#)
Description: This zip package include ESP8266-DevKitS schematics, PCB layout, gerber and BOM files, and spring design files.
- [*ESP8266 Quick Start Guide*](#)
Description: This document is a quick user guide to getting started with ESP8266. It includes an introduction to the ESP-LAUNCHER, how to download firmware on to the board and run it, how to compile the AT application, structure and the debugging method of RTOS SDK. Basic documentation and other related resources for the ESP8266 are also provided.
- [*ESP8266 SDK Getting Started Guide*](#)
Description: This document takes ESP-LAUNCHER and ESP-WROOM-02 as examples to introduce how to use ESP8266 SDK. The contents include preparations before compilation, SDK compilation and firmware download.
- [*ESP-WROOM-02 Datasheet*](#)
Description: ESP-WROOM-02 is a SMD module that integrates ESP8266EX. The module has been adjusted to get the best RF performance.
- [*ESP-WROOM-02D/ESP-WROOM-02U Datasheet*](#)
Description: ESP-WROOM-02D and ESP-WROOM-02U are ESP8266EX-based modules developed by Espressif. Compared with ESP-WROOM-02, the RF performance of ESP-WROOM-02D and ESP-WROOM-02U are optimized.
- [*ESP-WROOM-02 Reference Design*](#)
Description: This zip package includes ESP-WROOM-02 hardware downloading resources, manufacturing specifications, BOM and schematics.
- [*ESP-WROOM-02D/ESP-WROOM-02U Reference Design*](#)
Description: This zip package includes ESP-WROOM-02D and ESP-WROOM-02U module reference design resources, including schematics, PCB layout, gerber files and BOM lists.
- [*ESP-WROOM-02 PCB Design and Module Placement Guide*](#)
Description: The ESP-WROOM-02 module is designed to be soldered to a host PCB. This document compares six different placements of the antenna on a host board and provides notes on designing PCB.



- [*ESP8266 Hardware Resources*](#)
Description: This zip package includes manufacturing specifications of the ESP8266 board and the modules, manufacturing BOM and schematics.
- [*ESP8266 AT Command Examples*](#)
Description: This document introduces some specific examples of using Espressif AT commands, including single connection as a TCP Client, UDP transmission and transparent transmission, and multiple connection as a TCP server.
- [*ESP8266 AT Instruction Set*](#)
Description: This document provides lists of AT commands based on ESP8266_NONOS_SDK, including user-defined AT commands, basic AT commands, Wi-Fi AT commands and TCP/IP-related AT commands. It also introduces the downloading of AT firmware into flash.
- [*TCP/UDP UART Passthrough Test Demonstration*](#)
Description: This guide is intended to help users run a TCP & UDP passthrough test on the ESP8266 IoT platform.
- [*FAQ*](#)

A.2. Must-Have Resources

- [*ESP8266 SDKs*](#)
Description: This website page provides links to the latest version of ESP8266 SDK and the older ones.
- [*ESP8266 Tools*](#)
Description: This website page provides links to the ESP8266 flash download tools and ESP8266 performance evaluation tools.
- [*ESP8266 App*](#)
- [*ESP8266 Certification and Test Guide*](#)
- [*ESP8266 BBS*](#)
- [*ESP8266 Resources*](#)



Espressif IoT Team
www.espressif.com

Disclaimer and Copyright Notice

Information in this document, including URL references, is subject to change without notice.

THIS DOCUMENT IS PROVIDED AS IS WITH NO WARRANTIES WHATSOEVER, INCLUDING ANY WARRANTY OF MERCHANTABILITY, NON-INFRINGEMENT, FITNESS FOR ANY PARTICULAR PURPOSE, OR ANY WARRANTY OTHERWISE ARISING OUT OF ANY PROPOSAL, SPECIFICATION OR SAMPLE.

All liability, including liability for infringement of any proprietary rights, relating to use of information in this document is disclaimed. No licenses express or implied, by estoppel or otherwise, to any intellectual property rights are granted herein.

The Wi-Fi Alliance Member logo is a trademark of the Wi-Fi Alliance. The Bluetooth logo is a registered trademark of Bluetooth SIG.

All trade names, trademarks and registered trademarks mentioned in this document are property of their respective owners, and are hereby acknowledged.

Copyright © 2020 Espressif Inc. All rights reserved.