

THIS DRAWING IS UNPUBLISHED.

RELEASED FOR PUBLICATION

© COPYRIGHT - By -

ALL RIGHTS RESERVED.

REVISIONS

P	LTR	DESCRIPTION	DATE	DWN	APVD
	S3	REVISED PER ECR-19-008948	13MAY20	J.P	D.Z

- ① 0.00381 MIN BRIGHT TIN-LEAD PLATING ALL OVER.
- ② 0.00076 MIN GOLD PLATING ALL OVER.
- ③ REED STRAIGHT TOOTH KNURL CS 80-80 T.P.I., 125 TEETH, 70° INCLUDED ANGLE. FITS 1.50 - 1.57 DIAMETER HOLE IN A 1.59 PRINTED CIRCUIT BOARD.
- 4. PARTS TO COMPLY WITH AMP SOLDERABILITY SPECIFICATION 109-11-3.
- ⑤ MATES WITH AMP PARTS 60354 AND 60598.
- ⑥ 0.00381 MIN BRIGHT TIN PLATING ALL OVER.

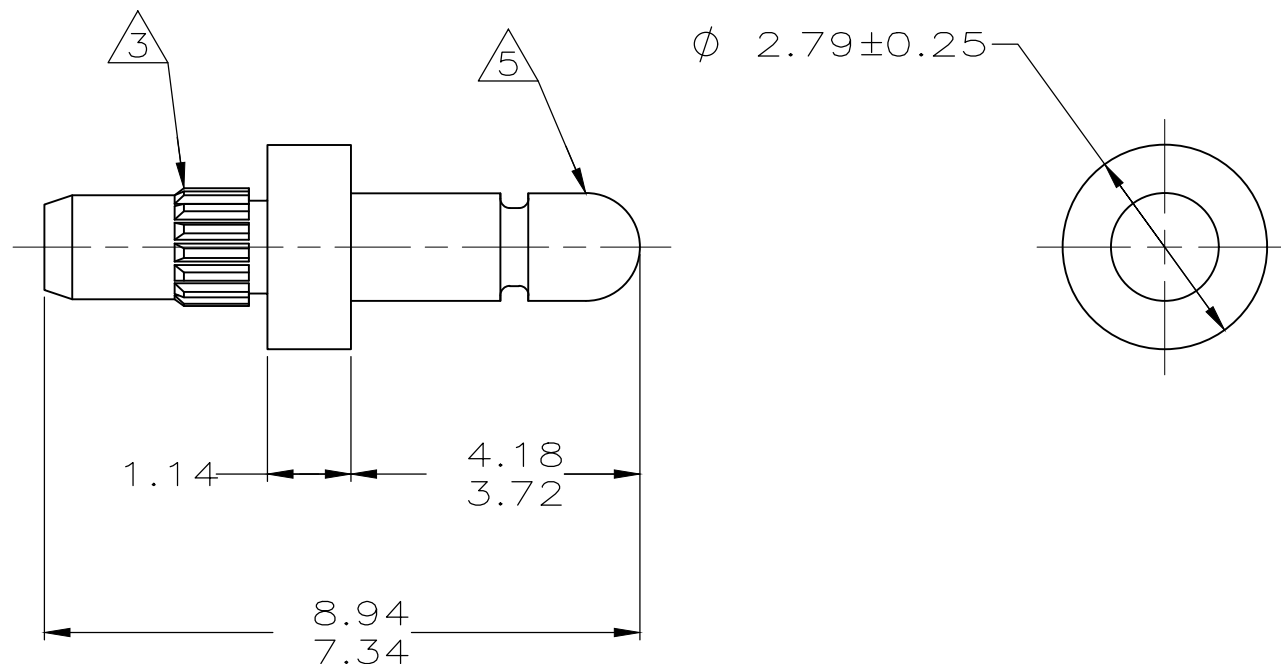

-	-
8.94	.352
7.34	.289
4.18	.165
3.72	.146
2.79	.110
1.59	.063
1.57	.062
1.50	.059
1.47	.058
1.14	.045
0.25	.010
0.13	.005
0.00381	.000150
0.00076	.000030
MM	IN

CONVERSION TABLE

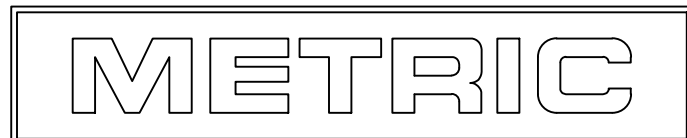

SUPERSEDED BY 3-60599-1

⑥	3-60599-1
②	60599-3
⑥	60599-1
FINISH	PART NUMBER

THIS DRAWING IS A CONTROLLED DOCUMENT.		DWN S. CARPENTER 21AUG2003	TE Connectivity		
DIMENSIONS: mm		CHK J. ELLIS 21AUG2003			
TOLERANCES UNLESS OTHERWISE SPECIFIED:		APVD J. ELLIS 21AUG2003	NAME PIN, .058 DIAMETER, BRASS, KNURLED, P.C. CONTACT		
0 PLC ± 1 PLC ± 2 PLC ± 0.13 3 PLC ± 4 PLC ± ANGLES ±		PRODUCT SPEC 108-1025	DRAWING NO C-60599		
MATERIAL BRASS		FINISH SEE TABLE	APPLICATION SPEC 114-1008	SIZE A3	CAGE CODE 00779
		WEIGHT 0.000000	DRAWING NO C-60599	RESTRICTED TO -	
CUSTOMER DRAWING			SCALE 10:1	SHEET 1 OF 1	REV S3